

*Sweetwater Creek
Community Development District*

Agenda

December 5, 2024

AGENDA

**Sweetwater Creek
Community Development District**
475 West Town Place, Suite 114
St. Augustine, Florida 32092
www.SweetwaterCreekCDD.com

November 27, 2024

Board of Supervisors
Sweetwater Creek Community Development District
Call In #: 1-877-304-9269; Code 186663

Dear Board Members:

The Sweetwater Creek Community Development District Board of Supervisors Meeting is scheduled for **Thursday, December 5, 2024 at 4:00 p.m. at the Fitness Center, 1865 N. Loop Parkway, St. Augustine, Florida 32095.**

Following is the agenda for the meeting:

- I. Roll Call
- II. Public Comment (limited to three minutes)
- III. Organizational Matters
 - A. Oath of Office for Newly Elected Supervisors
 - B. Consideration of Resolution 2025-03, Designating Officers
- IV. Approval of the Consent Agenda
 - A. Minutes of the November 7, 2024 Board of Supervisors Meeting
 - B. Financial Statements
 - C. Check Register
 - D. Ratification of Requisition No. 143
- V. Staff Reports
 - A. Landscape Team – Maintenance Report
 - B. District Engineer – Update Regarding Land Use of Parcel Conveyed to CDD
 - C. District Counsel
 - D. District Manager – Financial Update
 - E. Field Manager
 1. Report

2. Proposals for Sidewalk and Walking Path Concrete Repairs
- F. Director of Amenities
1. Report
 2. Quote for Shade Structures
 3. Quote for Miniature Golf Course Turf
 4. Quotes for Gym Equipment
 5. Estimate for Hallway Storage Conversion
 6. Estimate for Starting Block
 7. Proposal for Creation and Use of Land at Glorieta and Vale for Events
- VI. Update Regarding Capital Project Plan
- VII. Update Regarding Capital Reserve Study
- VIII. Other Business
- IX. Supervisor Requests / Public Comment
- X. Next Scheduled Meeting – Thursday, January 9, 2025 at 4:00 p.m. at the Fitness Center, 1865 N. Loop Parkway, St. Augustine, Florida 32095
- XI. Adjournment

PUBLIC CONDUCT: Members of the public are provided the opportunity for public comment during the meeting. Each member of the public is limited to three (3) minutes, at the discretion of the Presiding Officer, which may be shortened depending on the number of speakers. Speakers shall refrain from disorderly conduct, including launching personal attacks; the Presiding Officer shall have the discretion to remove any speaker that disregards the District's public decorum policies. Public comments are not a Q&A session; Board Supervisors are not expected to respond to questions during the public comment period.

THIRD ORDER OF BUSINESS

B.

RESOLUTION 2025-03

A RESOLUTION OF THE BOARD OF SUPERVISORS OF SWEETWATER CREEK COMMUNITY DEVELOPMENT DISTRICT DESIGNATING THE OFFICERS OF THE DISTRICT, AND PROVIDING FOR AN EFFECTIVE DATE.

WHEREAS, Sweetwater Creek Community Development District (the “District”) is a local unit of special-purpose government created and existing pursuant to Chapter 190, *Florida Statutes*, being situated entirely within the County of St. Johns, Florida; and

WHEREAS, the Board of Supervisors of the District desires to designate the Officers of the District.

NOW, THEREFORE, be it resolved by the Board of Supervisors of Sweetwater Creek Community Development District:

SECTION 1. _____ is appointed Chairman.

SECTION 2. _____ is appointed Vice Chairman.

SECTION 3. _____ is appointed Secretary and Treasurer.

_____ is appointed Assistant Secretary.

_____ is appointed Assistant Secretary.

_____ is appointed Assistant Secretary.

_____ is appointed Assistant Treasurer.

_____ is appointed Assistant Secretary.

_____ is appointed Assistant Secretary.

SECTION 4. This Resolution shall become effective immediately upon its adoption.

PASSED AND ADOPTED THIS 3RD DAY OF OCTOBER, 2024.

ATTEST

**SWEETWATER CREEK
COMMUNITY DEVELOPMENT
DISTRICT**

Secretary/Assistant Secretary

Chairman/Vice Chairman

FOURTH ORDER OF BUSINESS

A.

**MINUTES OF MEETING
SWEETWATER CREEK
COMMUNITY DEVELOPMENT DISTRICT**

The regular meeting of the Board of Supervisors of the Sweetwater Creek Community Development District was held on **Thursday, November 7, 2024** at 4:00 p.m. at the Fitness Center, 1865 N. Loop Parkway, St. Augustine, Florida.

Present and constituting a quorum were:

| | |
|----------------------------|---------------|
| Ron Cervelli | Chairman |
| John Smith <i>by phone</i> | Vice Chairman |
| Stephen Handler | Supervisor |
| Rob Lisotta | Supervisor |
| Dan Colin | Supervisor |

Also present were:

| | |
|----------------------------------|----------------------------------|
| Jim Oliver | District Manager, GMS |
| Mary Grace Henley <i>by Zoom</i> | District Counsel, KVW |
| Alex Acree <i>by Zoom</i> | District Engineer, Matthews DCCM |
| Erin Gunia | Director of Amenities, RMS |
| Dan Wright | Operations Manager, RMS |
| Michael Woolridge | Duval Landscape |
| Josh Boucher | Duval Landscape |

The following is a summary of the discussions and actions taken at the November 7, 2024 Sweetwater Creek Community Development District's Regular Board of Supervisors meeting.

FIRST ORDER OF BUSINESS

Roll Call

Mr. Cervelli called the meeting to order at 4:00 p.m. Four Board members were physically present, constituting a quorum.

SECOND ORDER OF BUSINESS

Public Comment

Erin Sharp stated that she appreciates the Board making the decision to invest into the putt putt area as she once heard it would be shut down.

THIRD ORDER OF BUSINESS

Approval of the Consent Agenda

A. Minutes of the October 3, 2024 Meeting

Copies of the minutes were included in the agenda package for the Board’s review.

B. Financial Statements

Copies of the financial statements were provided to the Board for their review.

C. Check Register

A copy of the check register was included in the agenda package for the Board’s review.

D. Ratification of Requisition Nos. 141 and 142

A copy of requisition 140 was included in the agenda package for the Board’s review.

On MOTION by Mr. Lisotta, seconded by Mr. Handler, with all in favor, the consent agenda was approved 5-0.

FOURTH ORDER OF BUSINESS

Staff Reports

A. Landscape Team

1. Maintenance Report

Mr. Woolridge provided an overview of the items that have been completed and that are still in progress. He informed the Board his team plans on applying topdressing to the help change the makeup of the soil following soil samples showing a nutrient deficiency.

2. Proposal for Flow Sensors on Pump Station

A proposal totaling \$2,900 to install flow sensors on two irrigation pumps was included in the agenda package for the Board’s review.

On MOTION by Mr. Lisotta, seconded by Mr. Colin, with all in favor, the consent agenda was approved 5-0.

B. District Engineer – Update Regarding Land Use of Parcel Conveyed to CDD

Mr. Acree stated that the engineer’s certificate was submitted to counsel’s office this week, so the conveyance should be nearing completion.

Additionally, he reported the St. Johns County Utilities force main installation project has been awarded and is scheduled to begin next week.

The Board directed Ms. Gunia to have an e-blast sent to inform residents of the project.

C. District Counsel

Ms. Henley informed the Board that Marshall Creek’s legal counsel has reviewed the revisions to the interlocal agreement that were requested by the Sweetwater board, and he will present those changes to the Marshall Creek board for approval. The clean-up deeds that her firm has been working on to track what is owned by the District have all been signed by Lennar and recorded in the public records. Lastly, she reminded the board members to complete the four hours of ethics training required annually by December 31st if they have not yet done so.

D. District Manager

Mr. Oliver informed the Board that the newly elected supervisors will be sworn in at the next meeting and the Board will re-designate the officers for the District. He also provided an overview of the financial state of the District, and reminded the Board the capital reserve study is in the process of being updated and should be presented at the next meeting.

F. Director of Amenities

1. Report

A copy of the amenities report was included in the agenda package for the Board’s review.

2. Quote for Shades Structures

A quote to add shade structures to the playground, bocce ball court, miniature golf course and pickleball court totaling \$150,000 was included in the agenda package for the Board’s review. Ms. Gunia noted she has asked for a revised quote from Superior Shade and is also seeking quotes from other vendors for the Board to consider.

Mr. Smith left the meeting by phone during this time.

No action was taken on this item.

3. Quote for Putt Putt Course Carpet

A quote to remove the existing turf on the miniature golf course, make any necessary repairs, and replace with new turf totaling \$21,800 was included in the agenda package for the Board’s review. Ms. Gunia noted she is awaiting additional quotes.

No action was taken on this item.

Next, Ms. Gunia proposed turning the back hallway in the fitness center into a closet with doors on each end for items that need climatized storage, such as holiday decorations. She estimates that would cost \$3,500 to \$4,000.

A. Field Manager – Report

A copy of the operations report was included in the agenda package for the Board’s review. Mr. Wright presented a proposal to replace two items on the Ensenada playground.

On MOTION by Mr. Lisotta, seconded by Mr. Cervelli, with all in favor, the proposal from Playmore was approved 4-0 with the funds to come from the Capital Projects fund.

Next, Mr. Wright presented a proposal from All Weather Contractors to repair the walking path at Ensenada and the sidewalks across from the walking path. He is expecting more proposals for this item.

No action was taken on this item.

Next, Mr. Wright informed the Board he and Supervisor Smith inspected the Rincon property following more reports of flooding and they both agreed the issue is the area behind the home is higher than the yard and is exacerbated by runoff from the homeowner’s gutters.

The Board agreed that effort has been made to reconcile the issue, however the lies with the elevation of the homeowner’s property.

Mr. Cervelli informed the Board that he has asked Ms. Gunia and Mr. Wright to make a list of items they think need to be addressed in the community.

SIXTH ORDER OF BUSINESS

**Consideration of Resolution 2025-02,
Amending the Fiscal Year 2024 Budget**

Mr. Oliver stated that the purpose of Resolution 2025-02 is to correct any line items over budget by transferring money from line items that fell under budget. He noted that there is a positive variance in the budget as a whole.

On MOTION by Dr. Handler, seconded by Mr. Lisotta, with all in favor, resolution 2025-02, amending the fiscal year 2024 budget was approved 4-0.

SEVENTH ORDER OF BUSINESS **Updated Regarding Capital Project Plan**

This item was discussed earlier in the meeting.

EIGHTH ORDER OF BUSINESS **Discussion of Capital Reserve Study**

Mr. Cervelli questioned if the Board members are going to go through the capital reserve study and mark up anything that needs to be changed.

Mr. Oliver stated that staff will go through the report line by line.

Mr. Lisotta stated that he will go through the report once staff has gone through and made any necessary corrections. Mr. Handler concurred.

NINTH ORDER OF BUSINESS **Discussion of Staff Performance Objectives**

Mr. Cervelli presented a list of objectives for staff to the other board members and noted District counsel has some recommended changes that he will incorporate, and he will submit an updated version for a future meeting.

TENTH ORDER OF BUSINESS **Discussion of Bonus Clause**

Mr. Cervelli stated that the bonus clause in the agreement needs to be rewritten and asked if the Board would allow the Chair to work with the District Manager on rewriting the process for awarding bonuses and finalizing that revision between meetings.

Mr. Lisotta asked that the bonuses that are ultimately given are made public. There were no objections otherwise.

ELEVENTH ORDER OF BUSINESS **Other Business**

Mr. Cervelli expressed concern over the process for gathering quotes for projects, particularly in a situation where RMS would bid on providing a service, such as pressure washing, and if RMS is awarded, RMS would oversee their own project, and GMS would approve payment.

Mr. Handler recommended excluding RMS from bidding in a situation such as that.

Mr. Lisotta stated that it is a valid concern, but if it is a common practice and the work is being done to a satisfactory level, why omit the lower bidder.

Mr. Colin suggested the board members individually inspect the work once it's complete to ensure the work was done properly.

TWELFTH ORDER OF BUSINESS Supervisor Requests / Public Comment

Donna Ewing commented in reference to the discussion on the financials, stating that if a certain amount is budgeted, there should be some coding or something so that can be referenced back. She also commented on the concern of RMS bidding on projects while soliciting bids from competitors on the same project, stating that in most cases, that is a conflict of interest because there are no checks and balances.

Karen Sharp commented that the idea of a project list is a great idea, and she hopes it is shared with the residents so that they can provide input.

A resident commented that a tree at 129 Dosel Lane started dying at the beginning of the summer and it was drastically trimmed down. She asked if any resident could claim that they have a tree in their backyard that needs to be taken down and it will be paid for by the CDD.

Mr. Lisotta responded that the stance of the District has always been that if a tree is dead and is in danger of falling on property, it must be removed because it's a liability.

**THIRTEENTH ORDER OF BUSINESS Next Scheduled Meeting – Thursday,
December 5, 2024 at 4:00 p.m. at the Fitness
Center, 1865 N. Loop Parkway, St. Augustine,
Florida 32095**

FOURTEENTH ORDER OF BUSINESS Adjournment

On MOTION by Mr. Lisotta, seconded by Dr. Handler, with all in favor, the meeting was adjourned.

Secretary/Assistant Secretary

Chairman/Vice Chairman

B.

Sweetwater Creek
Community Development District

Unaudited Financial Reporting
October 31, 2024



Table of Contents

| | |
|-------|---|
| 1 | <u>Balance Sheet</u> |
| 2-4 | <u>General Fund Income Statement</u> |
| 5 | <u>Debt Service Fund Series 2019 Income Statement</u> |
| 6 | <u>Capital Reserve Fund Income Statement</u> |
| 7 | <u>Capital Projects Income Statement</u> |
| 8-10 | <u>Month to Month</u> |
| 11 | <u>Long Term Debt Summary</u> |
| 12 | <u>Assessment Receipt Schedule</u> |
| 13-14 | <u>Construction Schedule</u> |

Sweetwater Creek
Community Development District
Combined Balance Sheet
October 31, 2024

| | General Fund | Debt Service Fund | Capital Reserve Fund | Capital Project Fund | Totals Governmental Funds |
|---|-------------------|----------------------|-------------------------|-------------------------|------------------------------|
| Assets: | | | | | |
| Cash: | | | | | |
| Operating Account General Fund | \$ 72,178 | \$ - | \$ 118,511 | - | \$ 190,689 |
| Operating Account Amenity Account | 74,590 | - | - | - | 74,590 |
| Debit Card Account | 1,655 | - | - | - | 1,655 |
| Assessments Receivable | - | - | - | - | - |
| Due from General Fund | - | - | - | - | - |
| Due from Others | 627 | - | - | - | 627 |
| Due from Capital Projects | - | - | 15,810 | - | 15,810 |
| | - | - | - | - | - |
| Investments: | | | | | |
| State Board of Administration (SBA) | 166,084 | - | 272,135 | - | 438,219 |
| US Bank Custody Account | 128,832 | - | - | - | 128,832 |
| | - | - | - | - | - |
| Series 2019 | | | | | |
| Reserve - A-1 | - | 133,070 | - | - | 133,070 |
| Reserve - A-2 | - | 108,331 | - | - | 108,331 |
| Revenue | - | 179,067 | - | - | 179,067 |
| Excess Revenue | - | 5 | - | - | 5 |
| Construction | - | - | - | 360,671 | 360,671 |
| Prepaid Expenses | 3,428 | - | - | - | 3,428 |
| Total Assets | \$ 447,394 | \$ 444,722 | \$ 406,456 | \$ 360,671 | \$ 1,659,243 |
| Liabilities: | | | | | |
| Accounts Payable | \$ 155,644 | \$ - | \$ - | \$ - | \$ 155,644 |
| Accrued Expenses | 310 | - | - | - | 310 |
| Contracts Payable | - | - | - | 1,509 | 1,509 |
| Due to Debt Service | - | - | - | - | - |
| Due to Amenity Fund | - | - | - | - | - |
| Due to Capital Reserve | - | - | - | 15,810 | 15,810 |
| Total Liabilities | \$ 155,954 | \$ - | \$ - | \$ 17,319 | \$ 173,273 |
| Fund Balance: | | | | | |
| Nonspendable: | | | | | |
| Prepaid Items | \$ 3,428 | \$ - | \$ - | \$ - | \$ 3,428 |
| Restricted for: | | | | | |
| Debt Service | - | 444,722 | - | - | 444,722 |
| Capital Project | - | - | - | 343,352 | 343,352 |
| Assigned for: | | | | | |
| Capital Reserve Fund | - | - | 406,456 | - | 406,456 |
| Unassigned | 288,012 | - | - | - | 288,012 |
| Total Fund Balances | \$ 291,440 | \$ 444,722 | \$ 406,456 | \$ 343,352 | \$ 1,485,971 |
| Total Liabilities & Fund Balance | \$ 447,394 | \$ 444,722 | \$ 406,456 | \$ 360,671 | \$ 1,659,243 |

Sweetwater Creek
Community Development District

General Fund

Statement of Revenues, Expenditures, and Changes in Fund Balance

For The Period Ending October 31, 2024

| | Adopted Budget | Prorated Budget Thru 10/31/24 | Actual Thru 10/31/24 | Variance |
|---|---------------------|----------------------------------|-------------------------|------------------|
| Revenues: | | | | |
| Special Assessments - Tax Roll | \$ 1,857,822 | \$ - | \$ - | \$ - |
| Fitness Center Revenue | 2,000 | 167 | 1,890 | 1,723 |
| Interest | 25,000 | 2,083 | 1,162 | (922) |
| Total Revenues | \$ 1,884,822 | \$ 2,250 | \$ 3,052 | \$ 802 |
| Expenditures: | | | | |
| <u>General & Administrative:</u> | | | | |
| Supervisor Fees | \$ 12,000 | \$ 1,000 | \$ 800 | 200 |
| Engineering | 20,000 | 1,667 | - | 1,667 |
| District Counsel | 63,599 | 5,300 | 3,814 | 1,486 |
| Annual Audit | 3,800 | 3,800 | - | 3,800 |
| Assessment Administration | 5,200 | 5,200 | 5,200 | - |
| Arbitrage Rebate | 500 | - | - | - |
| Dissemination Agent | 5,512 | 459 | 459 | 0 |
| Trustee Fees | 3,800 | 3,800 | 3,143 | 657 |
| Management Fees | 44,200 | 3,683 | 3,683 | 0 |
| Information Technology | 1,482 | 124 | 124 | - |
| Website Maintenance | 1,040 | 87 | 87 | (0) |
| Telephone | 742 | 62 | 36 | 26 |
| Postage & Delivery | 3,000 | 250 | 122 | 128 |
| Public Official Insurance | 5,172 | 5,172 | 850 | 4,322 |
| Copies | 2,500 | 208 | 153 | 55 |
| Legal Advertising | 2,000 | 167 | - | 167 |
| Miscellaneous | 1,500 | 397 | 397 | - |
| Dues, Licenses & Subscriptions | 175 | 175 | 175 | - |
| Cost Share Expense - Marshall Creek | 100,000 | - | - | - |
| Total General & Administrative | \$ 276,222 | \$ 31,551 | \$ 19,044 | \$ 12,507 |
| <u>Operations & Maintenance</u> | | | | |
| Utilities | | | | |
| Electric | \$ 78,000 | \$ 6,500 | \$ 6,062 | 438 |
| Other Physical Environment | | | | |
| General Insurance | 6,884 | 6,884 | 10,266 | (3,382) |
| Landscape Maintenance | 291,276 | 24,273 | 24,273 | - |
| Landscape Improvements | 50,000 | 4,167 | - | 4,167 |
| Mulch | 50,000 | 4,167 | - | 4,167 |
| Lake Maintenance | 22,000 | 1,833 | - | 1,833 |
| Fountain Maintenance | 1,500 | 125 | - | 125 |
| Irrigation Repairs & Maintenance | 39,000 | 3,250 | 9,095 | (5,845) |
| Storm Clean-Up | 10,000 | 833 | - | 833 |
| Field Repairs & Maintenance | 36,000 | 3,000 | 5,581 | (2,581) |
| Tree Removals | 14,000 | 1,167 | - | 1,167 |
| Tree Pruning | 15,000 | 1,250 | - | 1,250 |
| Streetlight Repairs | 2,250 | 188 | - | 188 |
| Signage Repairs | 1,000 | 83 | - | 83 |
| Holiday Decoration | 5,000 | 417 | 1,594 | (1,177) |
| Miscellaneous Field Supplies | 3,500 | 292 | 49 | 243 |
| Subtotal Other Physical Environment | \$ 625,410 | \$ 58,428 | \$ 56,920 | \$ 1,508 |

Sweetwater Creek
Community Development District

General Fund

Statement of Revenues, Expenditures, and Changes in Fund Balance

For The Period Ending October 31, 2024

| | Adopted Budget | Prorated Budget Thru 10/31/24 | Actual Thru 10/31/24 | Variance |
|--|---------------------|----------------------------------|-------------------------|--------------------|
| <i>Amenities</i> | | | | |
| Administrative | | | | |
| Property & Casualty Insurance | \$ 43,218 | \$ 43,218 | \$ 40,216 | 3,002 |
| Facility Management | 266,340 | 22,195 | 23,634 | (1,439) |
| Performance Incentive | 10,000 | 833 | - | 833 |
| Licenses & Permits | 770 | 64 | - | 64 |
| Subscriptions & Memberships | 2,040 | 170 | 125 | 45 |
| Office Supplies | 3,000 | 250 | 188 | 62 |
| Office Equipment | 2,500 | 208 | 107 | 101 |
| Communication - Telephone/Internet/TV | 12,000 | 1,000 | 663 | 337 |
| Internet/Telephone - Guard House | 4,500 | 375 | 653 | (278) |
| Field | | | | |
| Field Management Fees | 92,602 | 7,717 | 7,717 | (0) |
| General Utilities | 78,000 | 6,500 | 6,163 | 337 |
| Refuse Removal | 6,725 | 560 | 635 | (74) |
| Security | 41,137 | 3,428 | 3,488 | (60) |
| Janitorial Services | 43,467 | 3,622 | 3,622 | (0) |
| Operating Supplies - Spa & Paper | 4,000 | 333 | - | 333 |
| Operating Supplies - Uniforms | 500 | 42 | (84) | 126 |
| Cleaning Supplies | 12,500 | 1,042 | 67 | 975 |
| Amenity Landscape Maintenance & Improvements | 22,872 | 1,906 | 12,688 | (10,782) |
| Gate Repairs & Maintenance | 2,500 | 208 | - | 208 |
| Dog Park Repairs & Maintenance | 6,000 | 500 | 286 | 214 |
| Park Mulch | 5,000 | 417 | - | 417 |
| Miscellaneous Field Supplies | 4,100 | 342 | - | 342 |
| Buildings Repairs & Maintenance | 30,000 | 2,500 | 25,538 | (23,038) |
| Pest Control | 1,800 | 150 | 81 | 69 |
| Pool Maintenance - Contract | 19,469 | 1,622 | 1,622 | (0) |
| Pool Repairs & Maintenance | 3,000 | 250 | - | 250 |
| Pool Chemicals | 30,000 | 2,500 | 2,055 | 445 |
| Signage & Amenity Repairs | 300 | 25 | 61 | (36) |
| Special Events | 2,000 | 167 | - | 167 |
| Park Repair & Maintenance | 10,000 | 833 | - | 833 |
| Pickleball Repair & Maintenance | 3,000 | 250 | - | 250 |
| Guardhouse Maintenance | 2,500 | 208 | - | 208 |
| Playground Repairs & Maintenance | 5,000 | 417 | 17 | 400 |
| Fitness | | | | |
| Professional Services - Outside Fitness | 55,515 | 4,626 | 4,115 | 511 |
| Fitness Equipment Repairs & Maintenance | 7,000 | 583 | 351 | 232 |
| Fitness Equipment Rental | 36,635 | 3,053 | 3,053 | (0) |
| Miniature Golf Course Maintenance | 500 | 42 | - | 42 |
| Miscellaneous Fitness Supplies | 6,300 | 525 | 117 | 408 |
| Capital Outlay - Machinery & Equipment | 6,400 | 533 | - | 533 |
| Subtotal Amenities | \$ 883,190 | \$ 113,216 | \$ 137,176 | \$ (23,961) |
| Total Operations & Maintenance | \$ 1,508,600 | \$ 171,643 | \$ 194,096 | \$ (22,453) |
| Total Expenditures | \$ 1,784,822 | \$ 203,194 | \$ 213,140 | \$ (9,946) |
| Excess (Deficiency) of Revenues over Expenditures | \$ 100,000 | \$ (200,944) | \$ (210,088) | \$ (9,144) |

Sweetwater Creek

Community Development District

General Fund

Statement of Revenues, Expenditures, and Changes in Fund Balance

For The Period Ending October 31, 2024

| | Adopted | Prorated Budget | Actual | |
|--|---------------------|---------------------|---------------------|-------------------|
| | Budget | Thru 10/31/24 | Thru 10/31/24 | Variance |
| Other Financing Sources/(Uses): | | | | |
| Capital Reserve Transfer Out | \$ (100,000) | \$ - | - | \$ - |
| Total Other Financing Sources/(Uses): | \$ (100,000) | \$ - | \$ - | \$ - |
| Net Change in Fund Balance | \$ (0) | \$ (200,944) | \$ (210,088) | \$ (9,144) |
| Fund Balance - Beginning | \$ 51,387 | | \$ 501,528 | |
| Fund Balance - Ending | \$ 51,387 | | \$ 291,440 | |

Sweetwater Creek
Community Development District
Debt Service Fund Series 2019
Statement of Revenues, Expenditures, and Changes in Fund Balance
For The Period Ending October 31, 2024

| | Adopted Budget | Prorated Budget Thru 10/31/24 | Actual Thru 10/31/24 | Variance |
|--|-------------------|----------------------------------|-------------------------|------------------|
| Revenues: | | | | |
| Special Assessments - Tax Roll | \$ 741,440 | \$ - | \$ - | \$ - |
| Special Assessments - Prepayments | - | - | 10,926 | 10,926 |
| Interest Income | 30,000 | 2,500 | 1,724 | (776) |
| Total Revenues | \$ 771,440 | \$ 2,500 | \$ 12,650 | \$ 10,150 |
| Expenditures: | | | | |
| <i>Series 2019 - A1</i> | | | | |
| Interest - 11/01 | \$ 81,650 | \$ - | \$ - | \$ - |
| Interest - 5/1 | 81,650 | - | - | - |
| Principal - 5/1 | 360,000 | - | - | - |
| Special Call - 5/1 | - | - | - | - |
| <i>Series 2019 - A2</i> | | | | |
| Interest - 11/01 | 44,200 | - | - | - |
| Interest - 05/01 | 44,200 | - | - | - |
| Principal - 05/01 | 130,000 | - | - | - |
| Special Call - 5/1 | - | - | - | - |
| Total Expenditures | \$ 741,700 | \$ - | \$ - | \$ - |
| Excess (Deficiency) of Revenues over Expenditures | \$ 29,740 | \$ 2,500 | \$ 12,650 | \$ 10,150 |
| Other Financing Sources/(Uses): | | | | |
| Transfer In/(Out) | \$ - | \$ - | \$ - | \$ - |
| Total Other Financing Sources/(Uses) | \$ - | \$ - | \$ - | \$ - |
| Net Change in Fund Balance | \$ 29,740 | \$ 2,500 | \$ 12,650 | \$ 10,150 |
| Fund Balance - Beginning | \$ 187,616 | | \$ 432,072 | |
| Fund Balance - Ending | \$ 217,356 | | \$ 444,722 | |

Sweetwater Creek
Community Development District
Capital Reserve Fund

Statement of Revenues, Expenditures, and Changes in Fund Balance
For The Period Ending October 31, 2024

| | Adopted | Prorated Budget | Actual | |
|--|-------------------|-------------------|-------------------|-----------------|
| | Budget | Thru 10/31/24 | Thru 10/31/24 | Variance |
| Revenues | | | | |
| Capital Reserve - Transfer In | \$ 100,000 | \$ - | \$ - | \$ - |
| Interest | 5,000 | 417 | 1,159 | 743 |
| Miscellaneous Income | - | - | - | - |
| Insurance Proceeds | - | - | - | - |
| Total Revenues | \$ 105,000 | \$ 417 | \$ 1,159 | \$ 743 |
| Expenditures: | | | | |
| Capital Outlay | \$ 30,000 | \$ 2,500 | \$ - | \$ 2,500 |
| Repair & Maintenance | 21,317 | 1,776 | - | 1,776 |
| Other Current Charges | 600 | 50 | 40 | 10 |
| Reserve Study | - | - | - | - |
| Total Expenditures | \$ 51,917 | \$ 4,326 | \$ 40 | \$ 4,286 |
| Excess (Deficiency) of Revenues over Expenditures | \$ 53,083 | \$ (3,910) | \$ 1,119 | |
| Other Financing Sources/(Uses) | | | | |
| Transfer In and (Out) | \$ - | \$ - | \$ - | \$ - |
| Total Other Financing Sources (Uses) | \$ - | \$ - | \$ - | \$ - |
| Net Change in Fund Balance | \$ 53,083 | | \$ 1,119 | |
| Fund Balance - Beginning | \$ 444,309 | | \$ 405,337 | |
| Fund Balance - Ending | \$ 497,392 | | \$ 406,456 | |

Capital Reserve Study

| | <u>General</u> | <u>Amenities</u> | <u>Combined</u> |
|----------------------------|------------------------|------------------------|-----------------|
| Description | FY 2025-Study (Pg. 17) | FY 2024-Study (Pg. 20) | Total - Study |
| Reserves Beginning of Year | \$609,690 | \$164,002 | \$773,692 |
| Contributions | 196,300 | 65,100 | 261,400 |
| Interest Income | 10,186 | 6,162 | 16,348 |
| Expenditures | (217,373) | (21,088) | (238,461) |
| Anticipated Balance | \$598,803 | \$214,176 | \$812,979 |

Capital Reserve Fund - Actuals

| Description | Actual |
|--|------------|
| Reserves Beginning of Year | \$ 405,337 |
| Contributions | \$ - |
| Interest Income/Misc Income/Insurance Proceeds | \$ 1,159 |
| Expenditures | \$ (40) |
| Actual Balance | \$406,456 |

| | |
|---|--------------------|
| Variance Reserve Study Vs Actual | (\$406,523) |
|---|--------------------|

Sweetwater Creek
Community Development District
Capital Projects Fund Series 2019
Statement of Revenues, Expenditures, and Changes in Fund Balance
For The Period Ending October 31, 2024

| | Actual |
|--|-------------------|
| | Thru 10/31/24 |
| Revenues | |
| Interest Income | \$ 1,492 |
| Total Revenues | \$ 1,492 |
| Expenditures: | |
| Capital Outlay | \$ 332 |
| Total Expenditures | \$ 332 |
| Excess (Deficiency) of Revenues over Expenditures | \$ 1,160 |
| Other Financing Sources/(Uses) | |
| Transfer In/(Out) | \$ - |
| Total Other Financing Sources (Uses) | \$ - |
| Net Change in Fund Balance | \$ 1,160 |
| Fund Balance - Beginning | \$ 342,191 |
| Fund Balance - Ending | \$ 343,352 |

Sweetwater Creek
Community Development District
Month to Month

| | Oct | Nov | Dec | Jan | Feb | March | April | May | June | July | Aug | Sept | Total |
|---|------------------|-------------|-------------|-------------|-------------|-------------|-------------|-------------|-------------|-------------|-------------|-------------|---------------|
| Revenues: | | | | | | | | | | | | | |
| Special Assessments - Tax Roll | \$ - | \$ - | \$ - | \$ - | \$ - | \$ - | \$ - | \$ - | \$ - | \$ - | \$ - | \$ - | - |
| Fitness Center Revenue | 1,890 | - | - | - | - | - | - | - | - | - | - | - | 1,890 |
| Cost Sharing - Marshall Creek Revenue | - | - | - | - | - | - | - | - | - | - | - | - | - |
| Interest | 1,162 | - | - | - | - | - | - | - | - | - | - | - | 1,162 |
| Total Revenues | \$ 3,052 | \$ - | \$ - | \$ - | \$ - | \$ - | \$ - | \$ - | \$ - | \$ - | \$ - | \$ - | 3,052 |
| Expenditures: | | | | | | | | | | | | | |
| General & Administrative: | | | | | | | | | | | | | |
| Supervisor Fees | \$ 800 | \$ - | \$ - | \$ - | \$ - | \$ - | \$ - | \$ - | \$ - | \$ - | \$ - | \$ - | 800 |
| Engineering | - | - | - | - | - | - | - | - | - | - | - | - | - |
| District Counsel | 3,814 | - | - | - | - | - | - | - | - | - | - | - | 3,814 |
| Annual Audit | - | - | - | - | - | - | - | - | - | - | - | - | - |
| Assessment Administration | 5,200 | - | - | - | - | - | - | - | - | - | - | - | 5,200 |
| Arbitrage Rebate | - | - | - | - | - | - | - | - | - | - | - | - | - |
| Dissemination Agent | 659 | - | - | - | - | - | - | - | - | - | - | - | 659 |
| Trustee Fees | 3,143 | - | - | - | - | - | - | - | - | - | - | - | 3,143 |
| Management Fees | 3,683 | - | - | - | - | - | - | - | - | - | - | - | 3,683 |
| Information Technology | 124 | - | - | - | - | - | - | - | - | - | - | - | 124 |
| Website Maintenance | 87 | - | - | - | - | - | - | - | - | - | - | - | 87 |
| Telephone | 36 | - | - | - | - | - | - | - | - | - | - | - | 36 |
| Postage & Delivery | 122 | - | - | - | - | - | - | - | - | - | - | - | 122 |
| Public Official Insurance | 850 | - | - | - | - | - | - | - | - | - | - | - | 850 |
| Copies | 153 | - | - | - | - | - | - | - | - | - | - | - | 153 |
| Legal Advertising | - | - | - | - | - | - | - | - | - | - | - | - | - |
| Miscellaneous | 197 | - | - | - | - | - | - | - | - | - | - | - | 197 |
| Dues, Licenses & Subscriptions | 175 | - | - | - | - | - | - | - | - | - | - | - | 175 |
| Cost Share Expense - Marshall Creek | - | - | - | - | - | - | - | - | - | - | - | - | - |
| Total General & Administrative | \$ 19,044 | \$ - | \$ - | \$ - | \$ - | \$ - | \$ - | \$ - | \$ - | \$ - | \$ - | \$ - | 19,044 |

Sweetwater Creek
Community Development District
Month to Month

| | Oct | Nov | Dec | Jan | Feb | March | April | May | June | July | Aug | Sept | Total |
|--|------------------|-------------|-------------|-------------|-------------|-------------|-------------|-------------|-------------|-------------|-------------|-------------|---------------|
| Operations & Maintenance | | | | | | | | | | | | | |
| Utilities | | | | | | | | | | | | | |
| Electric | \$ 6,062 | \$ - | \$ - | \$ - | \$ - | \$ - | \$ - | \$ - | \$ - | \$ - | \$ - | \$ - | 6,062 |
| Other Physical Environment | | | | | | | | | | | | | |
| General Insurance | 10,266 | - | - | - | - | - | - | - | - | - | - | - | 10,266 |
| Landscape Maintenance | 24,273 | - | - | - | - | - | - | - | - | - | - | - | 24,273 |
| Landscape Improvements | - | - | - | - | - | - | - | - | - | - | - | - | - |
| Mulch | - | - | - | - | - | - | - | - | - | - | - | - | - |
| Lake Maintenance | - | - | - | - | - | - | - | - | - | - | - | - | - |
| Fountain Maintenance | - | - | - | - | - | - | - | - | - | - | - | - | - |
| Irrigation Repairs & Maintenance | 9,095 | - | - | - | - | - | - | - | - | - | - | - | 9,095 |
| Storm Clean-Up | - | - | - | - | - | - | - | - | - | - | - | - | - |
| Field Repairs & Maintenance | 5,581 | - | - | - | - | - | - | - | - | - | - | - | 5,581 |
| Tree Removals | - | - | - | - | - | - | - | - | - | - | - | - | - |
| Streetlight Repairs | - | - | - | - | - | - | - | - | - | - | - | - | - |
| Signage Repairs | - | - | - | - | - | - | - | - | - | - | - | - | - |
| Holiday Decoration | 1,594 | - | - | - | - | - | - | - | - | - | - | - | 1,594 |
| Miscellaneous Field Supplies | 49 | - | - | - | - | - | - | - | - | - | - | - | 49 |
| Subtotal Other Physical Environment | \$ 56,920 | \$ - | \$ - | \$ - | \$ - | \$ - | \$ - | \$ - | \$ - | \$ - | \$ - | \$ - | 56,920 |
| Amenities | | | | | | | | | | | | | |
| <i>Administrative</i> | | | | | | | | | | | | | |
| Property & Casualty Insurance | \$ 40,216 | \$ - | \$ - | \$ - | \$ - | \$ - | \$ - | \$ - | \$ - | \$ - | \$ - | \$ - | 40,216 |
| Facility Management | 23,634 | - | - | - | - | - | - | - | - | - | - | - | 23,634 |
| Licenses & Permits | - | - | - | - | - | - | - | - | - | - | - | - | - |
| Subscriptions & Memberships | 125 | - | - | - | - | - | - | - | - | - | - | - | 125 |
| Office Supplies | 188 | - | - | - | - | - | - | - | - | - | - | - | 188 |
| Office Equipment | 107 | - | - | - | - | - | - | - | - | - | - | - | 107 |
| Communication - Telephone/Internet/TV | 663 | - | - | - | - | - | - | - | - | - | - | - | 663 |
| Internet/Telephone - Guard House | 653 | - | - | - | - | - | - | - | - | - | - | - | 653 |

Sweetwater Creek
Community Development District
Month to Month

| | Oct | Nov | Dec | Jan | Feb | March | April | May | June | July | Aug | Sept | Total |
|--|---------------------|-------------|-------------|-------------|-------------|-------------|-------------|-------------|-------------|-------------|-------------|-------------|------------------|
| Field | | | | | | | | | | | | | |
| <i>Field Management Fees</i> | 7,717 | - | - | - | - | - | - | - | - | - | - | - | 7,717 |
| <i>General Utilities</i> | 6,163 | - | - | - | - | - | - | - | - | - | - | - | 6,163 |
| <i>Refuse Removal</i> | 635 | - | - | - | - | - | - | - | - | - | - | - | 635 |
| <i>Security</i> | 3,488 | - | - | - | - | - | - | - | - | - | - | - | 3,488 |
| <i>Janitorial Services</i> | 3,622 | - | - | - | - | - | - | - | - | - | - | - | 3,622 |
| <i>Operating Supplies - Spa & Paper</i> | - | - | - | - | - | - | - | - | - | - | - | - | - |
| <i>Operating Supplies - Uniforms</i> | (84) | - | - | - | (84) | - | - | - | - | - | - | - | (84) |
| <i>Cleaning Supplies</i> | 67 | - | - | - | - | - | - | - | - | - | - | - | 67 |
| <i>Amenity Landscape Maintenance & Improvements</i> | 12,688 | - | - | - | - | - | - | - | - | - | - | - | 12,688 |
| <i>Gate Repairs & Maintenance</i> | - | - | - | - | - | - | - | - | - | - | - | - | - |
| <i>Dog Park Repairs & Maintenance</i> | 286 | - | - | - | - | - | - | - | - | - | - | - | 286 |
| <i>Park Mulch</i> | - | - | - | - | - | - | - | - | - | - | - | - | - |
| <i>Miscellaneous Field Supplies</i> | - | - | - | - | - | - | - | - | - | - | - | - | - |
| <i>Buildings Repairs & Maintenance</i> | 25,538 | - | - | - | - | - | - | - | - | - | - | - | 25,538 |
| <i>Pest Control</i> | 81 | - | - | - | - | - | - | - | - | - | - | - | 81 |
| <i>Pool Maintenance - Contract</i> | 1,622 | - | - | - | - | - | - | - | - | - | - | - | 1,622 |
| <i>Pool Repairs & Maintenance</i> | - | - | - | - | - | - | - | - | - | - | - | - | - |
| <i>Pool Chemicals</i> | 2,055 | - | - | - | - | - | - | - | - | - | - | - | 2,055 |
| <i>Signage & Amenity Repairs</i> | 61 | - | - | - | - | - | - | - | - | - | - | - | 61 |
| <i>Special Events</i> | - | - | - | - | - | - | - | - | - | - | - | - | - |
| <i>Park Repair & Maintenance</i> | - | - | - | - | - | - | - | - | - | - | - | - | - |
| <i>Pickleball Repair & Maintenance</i> | - | - | - | - | - | - | - | - | - | - | - | - | - |
| <i>Guardhouse Maintenance</i> | - | - | - | - | - | - | - | - | - | - | - | - | - |
| <i>Playground Repairs & Maintenance</i> | 17 | - | - | - | - | - | - | - | - | - | - | - | 17 |
| Fitness | | | | | | | | | | | | | |
| <i>Professional Services - Outside Fitness</i> | 4,115 | - | - | - | - | - | - | - | - | - | - | - | 4,115 |
| <i>Fitness Equipment Repairs & Maintenance</i> | 351 | - | - | - | - | - | - | - | - | - | - | - | 351 |
| <i>Fitness Equipment Rental</i> | 3,053 | - | - | - | - | - | - | - | - | - | - | - | 3,053 |
| <i>Miniature Golf Course Maintenance</i> | - | - | - | - | - | - | - | - | - | - | - | - | - |
| <i>Miscellaneous Fitness Supplies</i> | 117 | - | - | - | - | - | - | - | - | - | - | - | 117 |
| <i>Capital Outlay - Machinery & Equipment</i> | - | - | - | - | - | - | - | - | - | - | - | - | - |
| Subtotal Amenities | \$ 137,176 | \$ - | \$ - | \$ - | \$ - | \$ - | \$ - | \$ - | \$ - | \$ - | \$ - | \$ - | 137,176 |
| Total Operations & Maintenance | \$ 194,096 | \$ - | \$ - | \$ - | \$ - | \$ - | \$ - | \$ - | \$ - | \$ - | \$ - | \$ - | 194,096 |
| Total Expenditures | \$ 213,140 | \$ - | \$ - | \$ - | \$ - | \$ - | \$ - | \$ - | \$ - | \$ - | \$ - | \$ - | 213,140 |
| Excess (Deficiency) of Revenues over Expenditures | \$ (210,088) | \$ - | \$ - | \$ - | \$ - | \$ - | \$ - | \$ - | \$ - | \$ - | \$ - | \$ - | (210,088) |
| Other Financing Sources/(Uses): | | | | | | | | | | | | | |
| <i>Capital Reserve Transfer Out</i> | - | - | - | - | - | - | - | - | - | - | - | - | - |
| Total Other Financing Sources/Uses | \$ - | \$ - | \$ - | \$ - | \$ - | \$ - | \$ - | \$ - | \$ - | \$ - | \$ - | \$ - | - |
| Net Change in Fund Balance | \$ (210,088) | \$ - | \$ - | \$ - | \$ - | \$ - | \$ - | \$ - | \$ - | \$ - | \$ - | \$ - | (210,088) |

Sweetwater Creek
Community Development District
Long Term Debt Report

| SERIES 2019A-1, SPECIAL ASSESSMENT REVENUE BONDS | |
|---|---|
| Interest Rate: | 2.000%, 2.125%, 2.250%, 2.375%, 2.500%, 2.950%, 3.170% |
| Maturity Date: | 5/1/2038 |
| Reserve Fund Definition | MAXIMUM ANNUAL DEBT SERVICE |
| Reserve Fund Requirement | \$133,070 |
| Reserve Fund Balance | 133,070 |
| Bonds Outstanding - 7/30/19 | \$7,825,000 |
| Less: Principal Payment - 5/1/20 | (\$330,000) |
| Less: Principal Payment - 5/1/20 (Special Call) | (\$15,000) |
| Less: Principal Payment - 11/1/20 (Special Call) | (\$40,000) |
| Less: Principal Payment - 5/1/21 | (\$340,000) |
| Less: Principal Payment - 5/1/21 (Special Call) | (\$40,000) |
| Less: Principal Payment - 11/1/21 (Special Call) | (\$15,000) |
| Less: Principal Payment - 5/1/22 | (\$340,000) |
| Less: Principal Payment - 11/1/22 (Special Call) | (\$15,000) |
| Less: Principal Payment - 5/1/23 | (\$345,000) |
| Less: Principal Payment - 5/1/24 | (\$355,000) |
| Less: Principal Payment - 5/1/24 (Special Call) | (\$10,000) |
| Current Bonds Outstanding | \$5,980,000 |

| SERIES 2019A-2, SPECIAL ASSESSMENT REVENUE BONDS | |
|---|---------------------------------|
| Interest Rate: | 3.560%, 4.020% |
| Maturity Date: | 5/1/2038 |
| Reserve Fund Definition | 50% MAXIMUM ANNUAL DEBT SERVICE |
| Reserve Fund Requirement | \$108,063 |
| Reserve Fund Balance | 108,331 |
| Bonds Outstanding - 7/30/19 | \$2,980,000 |
| Less: Principal Payment - 5/1/20 | (\$110,000) |
| Less: Principal Payment - 5/1/20 (Special Call) | (\$10,000) |
| Less: Principal Payment - 11/1/20 (Special Call) | (\$15,000) |
| Less: Principal Payment - 5/1/21 | (\$115,000) |
| Less: Principal Payment - 5/1/21 (Special Call) | (\$15,000) |
| Less: Principal Payment - 11/1/21 (Special Call) | (\$5,000) |
| Less: Principal Payment - 5/1/22 | (\$115,000) |
| Less: Principal Payment - 5/1/22 (Special Call) | (\$25,000) |
| Less: Principal Payment - 11/1/22 (Special Call) | (\$5,000) |
| Less: Principal Payment - 5/1/23 | (\$120,000) |
| Less: Principal Payment - 5/1/23 (Special Call) | (\$20,000) |
| Less: Principal Payment - 5/1/24 | (\$125,000) |
| Less: Principal Payment - 5/1/24 (Special Call) | (\$5,000) |
| Current Bonds Outstanding | \$2,295,000 |

Sweetwater Creek
COMMUNITY DEVELOPMENT DISTRICT
Special Assessment Receipts - St. John's County
Fiscal Year 2025

| | | | | | | |
|-------------------|----|--------------|----|------------|----|--------------|
| Gross Assessments | \$ | 1,976,407.34 | \$ | 785,758.55 | \$ | 2,762,165.89 |
| Net Assessments | \$ | 1,857,822.90 | \$ | 738,613.04 | \$ | 2,596,435.94 |

ON ROLL ASSESSMENTS

| | | | |
|-----------------|--------|--------|---------|
| allocation in % | 71.55% | 28.45% | 100.00% |
|-----------------|--------|--------|---------|

| Date | Distribution | Net Receipts | O&M Portion | 2019- Service | Debt | Total |
|--------------|--------------|---------------------|---------------------|--------------------|-----------|------------------|
| 11/05/24 | 1 | \$ 28,463.12 | \$ 20,366.16 | \$ 8,096.96 | \$ | 28,463.12 |
| | | - | - | - | - | - |
| | | - | - | - | - | - |
| | | - | - | - | - | - |
| | | - | - | - | - | - |
| | | - | - | - | - | - |
| | | - | - | - | - | - |
| | | - | - | - | - | - |
| | | - | - | - | - | - |
| | | - | - | - | - | - |
| | | - | - | - | - | - |
| | | - | - | - | - | - |
| | | - | - | - | - | - |
| | | - | - | - | - | - |
| | | - | - | - | - | - |
| | | - | - | - | - | - |
| | | - | - | - | - | - |
| | | - | - | - | - | - |
| TOTAL | | \$ 28,463.12 | \$ 20,366.16 | \$ 8,096.96 | \$ | 28,463.12 |

| | |
|------------------------|-------------------------------------|
| 1.10% | Percent Collected |
| \$ 2,567,972.82 | Balance Remaining to Collect |

Sweetwater Creek
COMMUNITY DEVELOPMENT DISTRICT

Special Assessment Revenue Bonds, Series 2019

| Date | Requisition # | Contractor | Description | Requisition |
|-------------------------|---------------|--|--|--------------|
| Fiscal Year 2020 | | | | |
| 11/15/19 | 1 | England Thims & Miller | Invoices: 191327, 191598, 191935 - Traffic Study & Certification Package | \$ 8,032.00 |
| 11/15/19 | 2 | East Coast Wells & Pump Service | Invoice: 34301 - Replaced Irrigation Pump | \$ 4,293.70 |
| 1/3/20 | 3 | Performance Painting Contractors, Inc. | Invoice: 9579 - Mobilization | \$ 8,090.00 |
| 1/3/20 | 4 | AC Concrete Enterprise, Inc. | Invoice: AB - Sidewalk Addition | \$ 6,250.00 |
| 1/3/20 | 5 | Reflections | Invoice: 191036 - Roof Clean | \$ 4,495.00 |
| 1/6/20 | 6 | Rick Arsenault Certified Pool Consultant, Inc. | Invoice: SWCrefC120 - 40% Deposit to start services | \$ 46,000.00 |
| 1/6/20 | 7 | Rick Arsenault Certified Pool Consultant, Inc. | Invoice: SWCrefD120 - 10% upon execution of the Agreement | \$ 11,500.00 |
| 2/6/20 | 8 | East Coast Wells & Pump Service | Invoices: 34271 & 34167 - Fixed Pump Motor & Replaced Bad Motor | \$ 2,137.00 |
| 2/6/20 | 9 | Rick Arsenault Certified Pool Consultant, Inc. | Invoice: SWCrefn120 - 10% Balance Upon Final Sign Off | \$ 11,500.00 |
| 2/24/20 | 10 | JLC Construction Inc. | Invoice: 1/20/2020 - Deposit for Perogola Replacement | \$ 6,790.80 |
| 2/26/20 | 11 | Performance Painting Contractors, Inc. | Invoice: 9578 - Power Wash and Paint | \$ 35,240.00 |
| 2/24/20 | 12 | Rick Arsenault Certified Pool Consultant, Inc. | Invoice: SWCrefF220 - 40% Commencement of Filling | \$ 46,000.00 |
| 2/26/20 | 13 | Rick Arsenault Certified Pool Consultant, Inc. | Invoice: SWCgtr220 - Gutter Grating Supports repaired | \$ 500.00 |
| 3/17/20 | 14 | Walter Carucci AE | Invoice: 1 - Services for Palencia Fitness Center from 11/11/19 thru 3/2/19 | \$ 5,034.68 |
| 3/17/20 | 15 | Bob's Backflow & Plumbing Services, Inc. | Invoice: 65745 - Back Flow Testing | \$ 265.00 |
| 3/23/20 | 16 | JLC Construction Inc. | Invoice: 3/20/2020 - Final payment for Perogola Replacement | \$ 6,790.80 |
| 4/8/20 | 17 | England Thims & Miller | Invoice: 0193131 Traffic Study & Certification Package | \$ 3,000.02 |
| 4/16/20 | 18 | England Thims & Miller | Invoice: 0193703 Traffic Study & Certification Package | \$ 1,062.00 |
| 5/20/20 | 19 | Fitness International Associates Corp | Invoice: 2904 Flooring | \$ 4,000.44 |
| 6/9/20 | 20 | Beacon Electrical Contractors Inc | Invoice: 200503 - Electrical work | \$ 16,357.00 |
| 6/15/20 | 21 | Sundancer Sign Graphics | Invoice: 2564 - Street Sign | \$ 12,310.00 |
| 6/22/20 | 22 | Yellowstone Landscape | Invoice: JAX120765 & JAX 120768 - Onda Field Full Irrigation & Sod | \$ 25,583.33 |
| 7/14/20 | 23 | Hopping Green & Sams | Invoice: 113207, 113803, 114427, 115066 - Project Construction | \$ 1,053.50 |
| 7/31/20 | 24 | Duval Asphalt | Invoice: 21750 - Stripping - Layout Stripe Crosswalks | \$ 1,458.00 |
| 8/7/20 | 25 | Yellowstone Landscape | Invoice: AJAX120768 - Onda Field Irrigation & Sod | \$ 24,722.16 |
| 9/10/20 | 26 | Radarsign | Invoice: 10761 - Solar Powered | \$ 7,888.00 |
| 9/10/20 | 27 | Hopping Green & Sams | Invoice: 116998 - Legal Services | \$ 559.00 |
| 9/14/20 | 28 | Sweetwater Creek CDD | Invoice: 2940 & 2904 Deposit paid via credit card for flooring | \$ 2,644.28 |
| 10/21/20 | 29 | Hopping Green & Sams | Invoice: 114427 - Legal services | \$ 258.00 |
| 10/29/20 | 30 | Hopping Green & Sams | Invoice #117953 - Project Construction Legal Services | \$ 1,075.00 |
| 11/16/20 | 31 | Clark Advisory Services, LLC | Services Rendered June 2020-October 2020 | \$ 5,034.00 |
| 2/17/21 | 32 | Yellowstone Landscape | Invoice #173437 - Irrigation Repairs | \$ 58,703.67 |
| 2/17/21 | 33 | Armstrong Fence Company | Invoice #20210221 - Deposit for Vinyl Coated chain-link Ensenda Park | \$ 2,570.79 |
| 5/13/21 | 34 | Armstrong Fence Company | Invoice #20210547 Remaining balance for Vinyl Coated chain-link | \$ 2,570.78 |
| 5/13/21 | 35 | Riverside Management Services | Invoice #13 Soccer Goals & Lacrosse Equipment | \$ 3,444.73 |
| 5/13/21 | 36 | Hopping Green & Sams | Invoice: 121275 - Legal Services | \$ 210.00 |
| 3/8/22 | 37 | England Thims & Miller | Invoice 0201371 - Engineer's Report | \$ 2,500.00 |
| 4/20/22 | 38 | Invision Construction | Invoice #0001 Fitness Center Expansion Process | \$ 2,000.00 |
| 4/20/22 | 39 | Basham & Lucas Desing Group Inc | Invoice #8851 Palencia Amenity & CDs | \$ 5,200.00 |
| 7/11/22 | 40 | Basham & Lucas Desing Group Inc | Invoice #8929 Palencia Amenity & CDs | \$ 3,889.78 |
| 6/22/22 | 41 | England Thims & Miller | Invoice #203006 Palencia Fitness Center Addition & Modification | \$ 3,750.00 |
| 6/22/22 | 42 | KE Law Group PLLC | Invoice #2879 2019 Project Construction | \$ 217.00 |
| 7/11/22 | 43 | Basham & Lucas Desing Group Inc | Invoice #8963 Palencia Amenity & CDs | \$ 13,600.00 |
| 8/8/22 | 44 | KE Law Group PLLC | Invoice #2993 2019 Project Construction | \$ 344.50 |
| 8/8/22 | 45 | England Thims & Miller | Invoice #203518 Palencia Fitness Center Addition & Modification | \$ 6,250.00 |
| 8/8/22 | 46 | Basham & Lucas Desing Group Inc | Invoice #9014 Palencia Amenity & CDs | \$ 13,025.00 |
| 9/19/22 | 47 | ECS Florida LLC | Palencia Fitness Center Addition Invoice #995173 | \$ 3,500.00 |
| 9/19/22 | 48 | England Thims & Miller | Invoice #204046 Palencia Fitness Center Addition & Modification | \$ 7,392.55 |
| 9/19/22 | 49 | Basham & Lucas Desing Group Inc | Invoice #9028 Palencia Amenity & CDs | \$ 8,046.25 |
| 9/19/22 | 50 | KE Law Group PLLC | Invoice #3599 2019 Project Construction | \$ 992.00 |
| 9/19/22 | 51 | England Thims & Miller | Invoice #204510 Palencia Fitness Center Addition & Modification | \$ 7,375.00 |
| 9/19/22 | 52 | KE Law Group PLLC | Invoice #3955 2019 Project Construction | \$ 726.00 |
| 11/8/22 | 53 | Bartram Trail Surveying | Invoice # 5394 Palencia Fitness Center Topographic Survey | \$ 2,900.00 |
| 11/8/22 | 54 | England Thims & Miller | Invoice #204943 Palencia Fitness Center Addition & Modification | \$ 15,013.75 |
| 11/8/22 | 55 | KE Law Group PLLC | Invoice #3955 2019 Project Construction | \$ 248.00 |
| 11/8/22 | 56 | Heartline Fitness Systems | Deposit Invoice #151945 50% deposit on Fitness Equipment | \$ 7,498.94 |
| 11/8/22 | 57 | Heartline Fitness Systems | Deposit Invoice #151948 50% deposit on Flooring Material | \$ 3,535.61 |
| 12/5/22 | 58 | England Thims & Miller | Invoice #205415 Palencia Fitness Center Addition & Modification | \$ 1,486.25 |
| 12/5/22 | 59 | Sweetwater Creek CDD-Capital Reserve | Studio 1+ Professional Design Services Inv #21.069 Palencia Fitness Club | \$ 10,375.00 |
| 12/13/22 | 60 | KE Law Group PLLC | Invoice #4873 2019 Project Construction | \$ 168.00 |
| 12/13/22 | 61 | Invision Construction | Invoice #PAL_001 Initial deposit per agreement | \$ 42,531.00 |
| 12/13/22 | 62 | England Thims & Miller | Invoice #204510 Palencia Fitness Center Addition & Modification | \$ 10,120.00 |
| 1/11/23 | 63 | Sweetwater Creek CDD | Palencia Interior Renovation Change Order Id #PAL_002 Invision Construction Inc | \$ 13,315.00 |
| 1/11/23 | 64 | England Thims & Miller | Invoice #205795 Palencia Fitness Center Addition & Modification | \$ 983.75 |
| 1/11/23 | 65 | KE Law Group PLLC | Invoice #5089 2019 Project Construction | \$ 31.00 |
| 1/11/23 | 66 | IT Systems of Jacksonville LLC | Invoice #1312 Deposit for New Audio System for Amenity Center | \$ 2,100.00 |
| 1/17/23 | 68 | Bartram Trail Surveying Inc | Invoice #5651 Palencia Fitness Cneter Topographic Survey 1/4/23 | \$ 3,080.00 |
| 2/14/23 | 67 | Sweetwater Creek CDD | Invoice #1226 Mirrors for Fitness Room - Nassau Windows & Glass | \$ 5,300.00 |
| 2/14/23 | 69 | England Thims & Miller | Invoice# 206344 Pickleball Courts Addition & Modifications | \$ 367.50 |
| | | | Invoice# 01.10.2023 Anastasia Pool & Spa Inc Gas Heater Replacement for Pool and Invoice# | |
| 2/14/23 | 70 | Sweetwater Creek CDD-Capital Reserve | PAL_004 Invision Construction Inc for Fitness Interior Renovation | \$ 16,218.00 |
| 2/14/23 | 71 | Sweetwater Creek CDD | Invoice #1231 Nassau Windows & Glass Inc. Rain Glass installation for gym | \$ 850.00 |
| 2/28/23 | 73 | Invision Construction | Final Payment per agreement for Palencia Interior Renovation | \$ 42,531.00 |
| 3/14/23 | 72 | Bartram Trail Surveying Inc | Invoice #5789 Palencia Fitness Cneter Topographic Survey 2/7/23 | \$ 770.00 |
| 4/4/23 | 74 | England Thims & Miller | Invoice# 207105 Pickleball Courts Addition & Modifications | \$ 6,275.00 |
| 4/24/23 | 75 | Design 2 Wellness | Invoice #41744 - Strength Equipment for remodel | \$ 21,441.00 |
| 4/24/23 | 76 | England Thims & Miller | Invoice# 207521 Pickleball Courts Addition & Modifications | \$ 9,617.50 |
| 4/24/23 | 77 | IT Systems of Jacksonville LLC | Invoice #1319 Wire work for coax for cameras | \$ 3,055.00 |
| 4/24/23 | 78 | Heartline Fitness Systems | Deposit Invoice #154186-F Final payment on Flooring Materials | \$ 3,827.85 |
| 4/24/23 | 79 | Sweetwater Creek CDD | Deposit Invoice #151945-F Final payment for Fitness Equipment | \$ 7,498.93 |
| 4/24/23 | 80 | Motley Electric | Invoice #266805595 Install Addt'l wiring/reconfigure circuits for Treadmill | \$ 1,020.00 |
| 4/24/23 | 81 | Feather & Bloom | Invoice #000714 Moss Wall & Painting for Zen Room | \$ 2,775.00 |
| 5/9/23 | 82 | Kilinski/Van Wyk PLLC | Invoice# 6480 2019 Project Construction | \$ 1,485.50 |
| 5/9/23 | 83 | Sweetwater Creek CDD | Invoice #1312 IT Systems Install amplifier and speakers. | \$ 2,100.00 |
| | | | Invoice # PAL_003 Invision Construction Additional Electrical items, HV AC pipe dryer vent, door, hall storage, trimming, painting, flooring, and plumbing washer. | \$ 15,000.00 |

**Sweetwater Creek
COMMUNITY DEVELOPMENT DISTRICT**

Special Assessment Revenue Bonds, Series 2019

| Date | Requisition # | Contractor | Description | Requisition |
|--------------|---------------|--|---|------------------------|
| 5/9/23 | 85 | Invision Construction | Progress billing per agreement for Palencia Interior Renovation Change Order Id #PAL_004 | \$ 5,190.00 |
| 5/15/23 | 86 | England Thims & Miller | Invoice# 208098 Pickle ball Courts Addition & Modifications. | \$ 3,023.75 |
| | | | Remaining Balance Invoice# 154021-F Final payment for Resistance Wall Gym & Cable Caddy | |
| 5/15/23 | 87 | Hearline Fitness Systems | Complete Kit and Training Ropes. | \$ 1,290.90 |
| 5/15/23 | 88 | Hearline Fitness Systems | Remaining Balance Invoice# 151948-F Final payment for Flooring Materials. | \$ 2,624.08 |
| 6/5/23 | 89 | Kilinski/Van Wyk PLLC | Invoice# 6585 2019 Project Construction | \$ 1,179.00 |
| 6/5/23 | 90 | Invision Construction | Change Order 4 Emergency Light Invoice #PAL_006 | \$ 600.00 |
| 6/5/23 | 91 | Feather & Bloom | Invoice #000725 Lighting install and custom hanging wood paneling for Zen Room | \$ 3,300.00 |
| 6/13/23 | 92 | England Thims & Miller | Invoice# 208489 Pickle ball Courts Addition & Modifications. | \$ 5,855.00 |
| 6/13/23 | 93 | Kilinski/Van Wyk PLLC | Invoice# 6846 2019 Project Construction | \$ 2,661.50 |
| 7/7/23 | 94 | England Thims & Miller | Invoice# 23159 Topography Survey for Onda Park | \$ 5,240.00 |
| 7/7/23 | 95 | Hoffman Commercial Construction LLC | Palencia Pickleball Courts Pay App 2304-1 | \$ 16,412.00 |
| 7/7/23 | 96 | England Thims & Miller | Invoice# 208897 Pickle ball Courts Addition & Modifications. | \$ 2,076.25 |
| 7/24/23 | 97 | Kilinski/Van Wyk PLLC | Invoice# 7090 2019 Project Construction | \$ 2,719.50 |
| 7/24/23 | 98 | Hoffman Commercial Construction LLC | Palencia Pickleball Courts Pay App 2304-2 | \$ 97,369.00 |
| 8/14/23 | 99 | England Thims & Miller | Invoice # 209405 Pickleball Courts Addition & Modifications. | \$ 563.75 |
| 8/14/23 | 100 | Kilinski/Van Wyk PLLC | Invoice # 7262 2019 Project Construction | \$ 482.00 |
| 8/16/23 | 101 | Hoffman Commercial Construction LLC | Palencia Pickleball Courts Pay App 2304-3 | \$ 111,695.00 |
| 9/15/23 | 102 | England Thims & Miller | Invoice # 209910 Pickleball Courts Addition & Modifications. | \$ 820.00 |
| 9/15/23 | 103 | Kilinski/Van Wyk PLLC | Invoice # 7481 2019 Project Construction | \$ 673.08 |
| 9/28/23 | 104 | Hoffman Commercial Construction LLC | Palencia Pickleball Courts Pay App 2304-4 | \$ 119,712.00 |
| 10/19/23 | 105 | Poly-Wood LLC | Invoice # 873994 Vineyard Dining Arm chairs and 48" Round Dining Tables | \$ 7,420.00 |
| 10/17/23 | 106 | Kilinski/Van Wyk PLLC | Invoice # 7759 2019 Project Construction | \$ 375.00 |
| 10/30/23 | 107 | American Electrical Contracting Inc | Palencia Pickleball Courts Electrical Lighting Install Invoice #W61855 | \$ 24,485.00 |
| 10/30/23 | 108 | Hoffman Commercial Construction LLC | Palencia Pickleball Courts Pay App 2304-5 | \$ 72,718.00 |
| 11/28/23 | 109 | Kilinski/Van Wyk PLLC | Invoice # 7975 2019 Project Construction | \$ 106.00 |
| 11/28/23 | 110 | Hoffman Commercial Construction LLC | Palencia Pickleball Courts Pay App 2304-6 | \$ 22,208.00 |
| 11/29/23 | 111 | England Thims & Miller | Invoice # 210296 Pickleball Courts Addition & Modifications. | \$ 256.25 |
| 12/7/23 | 112 | England Thims & Miller | Invoice # 210807 Pickleball Courts Addition & Modifications. | \$ 367.45 |
| | | | Pickleball fees, sound system upgrade aerobics room, and Washer Dryer/Warranty for Amenity | |
| 12/5/23 | 113 | Sweetwater Creek CDD | Center paid with card. | \$ 2,959.95 |
| 12/6/23 | 114 | England Thims & Miller | Invoice # 211276 Pickleball Courts Addition & Modifications. | \$ 205.00 |
| 1/10/24 | 115 | Duval Landscape Maintenance | Invoice # 25237 Revamp amenity center irrigation. | \$ 12,917.16 |
| 1/10/24 | 116 | Sweetwater Creek CDD-Capital Reserve | Dowling Douglas Invoice # 211276 Pickleball Courts Addition & Modifications – Nov 2023. | \$ 2,600.00 |
| 1/22/24 | 117 | Kilinski/Van Wyk PLLC | Invoice # 8459 2019 Project Construction | \$ 124.00 |
| 2/13/24 | 118 | Atlantic Security | Video Surveillance System Equipment and Installation 50% Dep Invoice #327381-Deposit | \$ 5,946.88 |
| 2/13/24 | 119 | Alfred W Grover, Electrical Contractor | Invoice # 12524 - 6 Outdoor Motion Detector-LED light fixture for Pickleball Project | \$ 3,800.00 |
| 2/13/24 | 120 | England Thims & Miller | Invoice # 212440 Pickleball Courts Addition & Modifications - Nov 2023. | \$ 1,571.25 |
| 2/14/24 | 121 | Kilinski/Van Wyk PLLC | Invoice # 8723 2019 Project Construction | \$ 155.00 |
| 2/20/24 | 122 | American Electrical Contracting Inc | Palencia Pickleball Courts Install two light deflectors Invoice #W64623 | \$ 1,840.00 |
| 2/22/24 | 123 | American Electrical Contracting Inc | Palencia Pickleball Courts Change timer to digital Invoice #W63086 | \$ 140.65 |
| 2/22/24 | 124 | American Electrical Contracting Inc | Palencia Pickleball Courts Change Order Lighting Project Invoice #W62910 | \$ 3,227.30 |
| 2/27/24 | 125 | Hoffman Commercial Construction LLC | Palencia Pickleball Courts Pay App 2304-7-Final Payment | \$ 25,623.00 |
| 3/12/24 | 126 | Workman's Kwik Fix Plumbing Division | Invoice # 97146 – installed self close metering faucet in ensenada park per contract | \$ 1,280.00 |
| | | | Invoice #212712 – CEI Services - Finalized documents and pay apps for Pickleball Court | |
| 3/12/24 | 127 | England Thims & Miller | closeout with SJC and Owner | \$ 307.50 |
| | | | Invoice # 2313106. Furnished & installed 296' of 48" high 2-rail ascot style black aluminum | |
| 3/12/24 | 128 | Best Fence and Rail fo FL LLC | fence with (3) 4' gate | \$ 8,174.00 |
| 3/20/24 | 129 | Kilinski/Van Wyk PLLC | Invoice # 8974 2019 Project Construction | \$ 1,437.50 |
| 4/30/24 | 130 | Matthews/DCCM | Invoice # 190784 - Due Diligence and Site Planning | \$ 2,168.75 |
| 5/20/24 | 131 | Matthews/DCCM | Invoice # 190937 - Due Diligence and Site Planning | \$ 2,037.50 |
| 5/31/24 | 132 | Atlantic Security | Invoice # 331612Final Invoice for Securiyt System | \$ 5,884.37 |
| 6/11/24 | 133 | Kilinski/Van Wyk PLLC | Invoice # 9385 2019 Project Construction | \$ 393.50 |
| 6/27/24 | 134 | Kilinski/Van Wyk PLLC | Invoice # 9385 2019 Project Construction | \$ 465.00 |
| 7/26/24 | 135 | Kilinski/Van Wyk PLLC | Invoice # 9861 2019 Project Construction | \$ 93.00 |
| 8/5/24 | 136 | Matthews/DCCM | Invoice # 191118 - Due Diligence and Site Planning | \$ 2,475.00 |
| 8/5/24 | 137 | Matthews/DCCM | Invoice # 191467 - Onda Park Survey and Construction Plans | \$ 9,489.26 |
| 8/21/24 | 138 | Matthews/DCCM | Invoice # 191636 - Onda Park Construction Plans/Landscape/Meetings | \$ 5,100.00 |
| 8/28/24 | 139 | Kilinski/Van Wyk PLLC | Invoice # 10065 2019 Project Construction | \$ 583.00 |
| 9/13/24 | 140 | Kilinski/Van Wyk PLLC | Invoice # 10430 2019 Project Construction | \$ 3,403.50 |
| | 141 | Matthews/DCCM | Invoice #191859 Onda Park | \$ 1,186.88 |
| 10/18/24 | 142 | Kilinski/Van Wyk PLLC | Invoice # 10546 2019 Project Construction | \$ 332.00 |
| | 143 | Sweetwater Creek CDD-Capital Reserve | Envera System upgrade deposit and install balance | \$ 15,810.12 |
| TOTAL | | | | \$ 1,342,903.92 |

| | |
|---|-------------------|
| Project (Construction) Fund at 08/30/19 | \$ 1,540,777.96 |
| Interest Earned and Transfers thru 10/31/24 | \$ 145,799.66 |
| Outstanding Requisitions | \$ 16,997.00 |
| Requisitions Paid thru 10/31/24 | \$ (1,342,903.92) |

| | |
|--|----------------------|
| Remaining Project (Construction) Fund | \$ 360,670.70 |
|--|----------------------|

FUTURE CAPITAL PROJECTS (CONSTRUCTION)

| | | |
|---|---|---------------------|
| Hoffman Construction | Pickleball Court Construction-Balance to Finish including Retainage | \$0.00 |
| | Pickleball-Water Fountain/Cooler (Projection, not actual) | \$4,000.00 |
| | Fitness Center New Equipment | \$115,000.00 |
| | Boccee Ball Court And Shade | \$40,000.00 |
| | Shade Srtures Playgrounds, Pickleball | \$140,000.00 |
| | Parking Lot for Golf Carts | \$12,000.00 |
| | Dog Park - Las Calinas/Glorietta | \$25,000.00 |
| District Engineer Costs related to Projects | District Engineer Costs (Projection, not actual) | \$0.00 |
| District Counsel Costs related to Projects | District Counsel Costs (Projection, not actual) | \$0.00 |
| TOTAL PROJECTED PROJECTS | | \$336,000.00 |

C.

Sweetwater Creek
COMMUNITY DEVELOPMENT DISTRICT

Fiscal Year 2024
Check Register

| <i>Date</i> | <i>check #'s</i> | <i>Amount</i> |
|---------------------|------------------|--------------------|
| General Fund | | |
| 10/03/24 | 4135-4140 | \$12,407.47 |
| 10/07/24 | 4141-4144 | \$800.00 |
| 10/24/24 | 4145-4155 | \$46,601.30 |
| SUBTOTAL | | \$59,808.77 |

| <i>Date</i> | <i>check #'s</i> | <i>Amount</i> |
|---------------------|------------------|--------------------|
| Amenity Fund | | |
| 10/03/24 | 2728-2741 | \$6,172.18 |
| 10/24/24 | 2742-2770 | \$15,842.23 |
| SUBTOTAL | | \$22,014.41 |

| <i>Date</i> | <i>check #'s</i> | <i>Amount</i> |
|------------------------|------------------|--------------------|
| Capital Reserve | | |
| 10/03/24 | 38 | \$20,863.28 |
| SUBTOTAL | | \$20,863.28 |

| | | |
|--------------|--|---------------------|
| TOTAL | | \$102,686.46 |
|--------------|--|---------------------|

| CHECK DATE | VEND# | INVOICE DATE | INVOICE | EXPENSED TO YRMO | DPT | ACCT# | SUB | SUBCLASS | VENDOR NAME | STATUS | AMOUNT | CHECK AMOUNT | CHECK # |
|------------|-------|--------------|----------|------------------|-----|-------|-------|----------|----------------------------------|--------|----------|--------------|---------|
| 10/03/24 | 00090 | 8/29/24 | 6641476 | 202408 | 310 | 51300 | 48000 | | GANNETT FL LOCALIQ | * | 101.28 | 101.28 | 004135 |
| 10/03/24 | 00086 | 7/25/24 | 27963 | 202407 | 320 | 53800 | 47300 | | DUVAL LANDSCAPE MAINTENANCE | * | 2,500.00 | 2,500.00 | 004136 |
| 10/03/24 | 00086 | 7/29/24 | 27995 | 202407 | 320 | 53800 | 46200 | | DUVAL LANDSCAPE MAINTENANCE | * | 1,028.70 | 1,028.70 | 004137 |
| 10/03/24 | 00086 | 9/18/24 | 28615 | 202409 | 320 | 53800 | 47300 | | DUVAL LANDSCAPE MAINTENANCE | * | 2,200.00 | 2,200.00 | 004138 |
| 10/03/24 | 00029 | 9/15/24 | 162 | 202410 | 310 | 51300 | 31700 | | GOVERNMENTAL MANAGEMENT SERVICES | * | 5,200.00 | 5,200.00 | 004139 |
| 10/03/24 | 00103 | 7/10/24 | 191465 | 202406 | 310 | 51300 | 31100 | | MATTHEWS DESIGN GROUP LLC | * | 1,377.49 | 1,377.49 | 004140 |
| 10/07/24 | 00089 | 10/03/24 | 10032024 | 202410 | 310 | 51300 | 11000 | | JOHN T SMITH | * | 200.00 | 200.00 | 004141 |
| 10/07/24 | 00051 | 10/03/24 | 10032024 | 202410 | 310 | 51300 | 11000 | | ROBERT LISOTTA | * | 200.00 | 200.00 | 004142 |
| 10/07/24 | 00108 | 10/03/24 | 10032024 | 202410 | 310 | 51300 | 11000 | | RONALD J CERVELLI | * | 200.00 | 200.00 | 004143 |
| 10/07/24 | 00040 | 10/03/24 | 10032024 | 202410 | 310 | 51300 | 11000 | | STEPHEN J HANDLER | * | 200.00 | 200.00 | 004144 |
| 10/24/24 | 00105 | 10/08/24 | 185748 | 202410 | 320 | 53800 | 47301 | | ALL WEATHER CONTRACTORS, INC | * | 4,370.00 | 4,370.00 | 004145 |
| 10/24/24 | 00090 | 7/31/24 | 6583534 | 202407 | 310 | 51300 | 48000 | | | * | 1,182.19 | | |

SWCC SWEETWATER CRK BPEREGRINO

| CHECK DATE | VEND# | INVOICE DATE | INVOICE | EXPENSED TO YRMO | DPT ACCT# | SUB SUBCLASS | VENDOR NAME | STATUS | AMOUNT | CHECK AMOUNT | CHECK # |
|----------------------------------|-------|--------------|---------|------------------|-------------|---------------------------|--------------------------|--------|-----------|--------------|---------|
| 7/31/24 | | 6583534 | 202407 | 310 | 51300 | 48000 | JOINT MTG #10350522 | * | 102.64 | | |
| 7/31/24 | | 6583534 | 202407 | 310 | 51300 | 48000 | 8/5 MTG #10413992 | * | 90.40 | | |
| GANNETT FL LOCALIQ | | | | | | | | | | 1,375.23 | 004146 |
| 10/24/24 | 00086 | 10/01/24 | 28887 | 202410 | 320 | 53800-46200 | OCT PALENCIA RENEWAL | * | 24,273.00 | | |
| DUVAL LANDSCAPE MAINTENANCE | | | | | | | | | | 24,273.00 | 004147 |
| 10/24/24 | 00009 | 8/23/24 | 24666 | 202410 | 310 | 51300-46000 | FY25 WORKERS COMP | * | 850.00 | | |
| EGIS INSURANCE ADVISORS LLC | | | | | | | | | | 850.00 | 004148 |
| 10/24/24 | 00106 | 10/11/24 | 1132 | 202410 | 320 | 53800-47301 | LINE PAINTING-REPAINT | * | 554.00 | | |
| VOLKMANN INVESTMENTS INC DBA | | | | | | | | | | 554.00 | 004149 |
| 10/24/24 | 00063 | 9/30/24 | 86187 | 202409 | 320 | 53800-47000 | SEP LAKE MAINTENANCE | * | 2,122.44 | | |
| FUTURE HORIZONS | | | | | | | | | | 2,122.44 | 004150 |
| 10/24/24 | 00029 | 10/01/24 | 163 | 202410 | 310 | 51300-34000 | OCT MANAGEMENT FEES | * | 3,683.33 | | |
| 10/01/24 | | 163 | 202410 | 310 | 51300-35200 | OCT WEBSITE ADMIN | * | 86.67 | | | |
| 10/01/24 | | 163 | 202410 | 310 | 51300-35100 | OCT INFO TECH | * | 123.50 | | | |
| 10/01/24 | | 163 | 202410 | 310 | 51300-31300 | OCT DISSEM AGENT SRVCS | * | 459.33 | | | |
| 10/01/24 | | 163 | 202410 | 310 | 51300-49000 | OFFICE SUPPLIES | * | 22.39 | | | |
| 10/01/24 | | 163 | 202410 | 310 | 51300-42000 | POSTAGE | * | 122.14 | | | |
| 10/01/24 | | 163 | 202410 | 310 | 51300-42500 | COPIES | * | 153.45 | | | |
| 10/01/24 | | 163 | 202410 | 310 | 51300-41000 | TELEPHONE | * | 35.87 | | | |
| 10/01/24 | | 163 | 202410 | 310 | 51300-49000 | 8/20 AMEX-HOLIDAY INN EXP | * | 175.00 | | | |
| 10/01/24 | | 163 | 202410 | 320 | 53800-49000 | POOL CHEM-MURIATIC ACID | * | 48.93 | | | |
| GOVERNMENTAL MANAGEMENT SERVICES | | | | | | | | | | 4,910.61 | 004151 |
| 10/24/24 | 00094 | 10/12/24 | 10547 | 202409 | 310 | 51300-31500 | SEP SMALL CLAIMS LAWSUIT | * | 51.00 | | |
| KILINSKI VAN WYK, PLLC | | | | | | | | | | 51.00 | 004152 |

SWCC SWEETWATER CRK BPEREGRINO

| CHECK DATE | VEND# |INVOICE..... DATE INVOICE | ...EXPENSED TO... YRMO DPT ACCT# SUB SUBCLASS | VENDOR NAME | STATUS | AMOUNT |CHECK..... AMOUNT # |
|--------------------|-------|-----------------------------------|--|---|--------|-----------|----------------------------|
| 10/24/24 | 00094 | 10/14/24 10545 | 202409 310-51300-31500 | SEP GENERAL COUNSEL KILINSKI VAN WYK, PLLC | * | 5,338.50 | 5,338.50 004153 |
| 10/24/24 | 00103 | 10/10/24 191965 | 202409 310-51300-31100 | SEP ENGINEERING SERVICES MATTHEWS DESIGN GROUP LLC | * | 1,695.00 | 1,695.00 004154 |
| 10/24/24 | 00071 | 9/23/24 286 | 202408 320-53800-47301 | AUG FACILITY MAINTENANCE RIVERSIDE MANAGEMENT SERVICES | * | 1,061.52 | 1,061.52 004155 |
| TOTAL FOR BANK A | | | | | | 59,808.77 | |
| TOTAL FOR REGISTER | | | | | | 59,808.77 | |



| | | | |
|---|--|---|-------------------------|
| ACCOUNT NAME Sweetwater Creek Cdd/Gms | | ACCOUNT # 764151 | PAGE # 1 of 1 |
| INVOICE # 0006641476 | BILLING PERIOD Aug 1- Aug 31, 2024 | PAYMENT DUE DATE September 20, 2024 | |
| PREPAY (Memo Info) \$0.00 | UNAPPLIED (Included in amt due) \$0.00 | TOTAL CASH AMT DUE* \$1,476.51 | |

BILLING ACCOUNT NAME AND ADDRESS

Sweetwater Creek Cdd/Gms
475 W. Town Pl. Ste. 114
Saint Augustine, FL 32092-3649



Legal Entity: Gannett Media Corp.
Terms and Conditions: Past due accounts are subject to interest at the rate of 18% per annum or the maximum legal rate (whichever is less). Advertiser claims for a credit related to rates incorrectly invoiced or paid must be submitted in writing to Publisher within 30 days of the invoice date or the claim will be waived. Any credit towards future advertising must be used within 30 days of issuance or the credit will be forfeited.
All funds payable in US dollars.

BILLING INQUIRIES/ADDRESS CHANGES 1-877-736-7612 or smb@ccc.gannett.com **FEDERAL ID** 47-2390983

To sign-up for E-mailed invoices and online payments please contact abgspecial@gannett.com.

| Date | Description | Amount |
|--------|-----------------|------------|
| 8/1/24 | Balance Forward | \$1,375.23 |

Package Advertising:

| Start-End Date | Order Number | Product | Description | PO Number | Package Cost |
|----------------|--------------|-------------------------|-------------------------|-----------|--------------|
| 8/29/24 | 10489443 | SAG St Augustine Record | Notice of Meeting Dates | | \$101.28 |

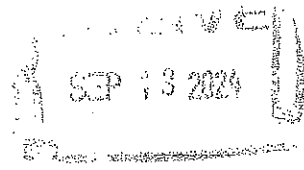

As an Incentive for customers, we provide a discount off the total invoice cost equal to the 3.99% service fee if you pay with Cash/Check/ACH. Pay by Cash/Check/ACH and Save!

| | |
|-----------------------------------|------------|
| Total Cash Amount Due | \$1,476.51 |
| Service Fee 3.99% | \$58.91 |
| *Cash/Check/ACH Discount | -\$58.91 |
| *Payment Amount by Cash/Check/ACH | \$1,476.51 |
| Payment Amount by Credit Card | \$1,535.42 |

PLEASE DETACH AND RETURN THIS PORTION WITH YOUR PAYMENT

| | | | | | | |
|---|---------------------------------------|-----------------------------------|-----------------------------------|--|-------------------------------------|--|
| ACCOUNT NAME Sweetwater Creek Cdd/Gms | | ACCOUNT NUMBER 764151 | | INVOICE NUMBER 0006641476 | | AMOUNT PAID \$101.28 |
| CURRENT DUE \$101.28 | 30 DAYS PAST DUE \$1,375.23 | 60 DAYS PAST DUE \$0.00 | 90 DAYS PAST DUE \$0.00 | 120+ DAYS PAST DUE \$0.00 | UNAPPLIED PAYMENTS \$0.00 | TOTAL CASH AMT DUE* \$1,476.51 |
| REMITTANCE ADDRESS (Include Account# & Invoice# on check) | | | | TO PAY WITH CREDIT CARD PLEASE CALL: | | TOTAL CREDIT CARD AMT DUE |
| Gannett Florida LocaliQ PO Box 631244 Cincinnati, OH 45263-1244 | | | | 1-877-736-7612 | | \$1,535.42 |
| | | | | To sign up for E-mailed invoices and online payments please contact abgspecial@gannett.com | | |

0000764151000000000000066414760014765167170

LOCALIQ FLORIDA

PO Box 631244 Cincinnati, OH 45263-1244

AFFIDAVIT OF PUBLICATION

Courtney Hogge
Sweetwater Creek Cdd/Gms
475 West Town Place, Suite 114

Saint Augustine FL 32092

STATE OF WISCONSIN, COUNTY OF BROWN

Before the undersigned authority personally appeared, who on oath says that he or she is the Legal Coordinator of the St Augustine Record, published in St Johns County, Florida; that the attached copy of advertisement, being a Public Notices, was published on the publicly accessible website of St Johns County, Florida, or in a newspaper by print in the issues of, on:

08/29/2024

Affiant further says that the website or newspaper complies with all legal requirements for publication in chapter 50, Florida Statutes.

Subscribed and sworn to before me, by the legal clerk, who is personally known to me, on 08/29/2024

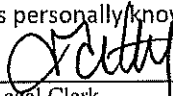

Legal Clerk

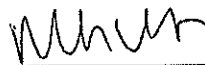

Notary, State of WI, County of Brown

8.29.26

My commission expires

| | | |
|-------------------|----------|--------------|
| Publication Cost: | \$101.28 | |
| Tax Amount: | \$0.00 | |
| Payment Cost: | \$101.28 | |
| Order No: | 10489443 | # of Copies: |
| Customer No: | 764151 | 1 |
| PO #: | | |

THIS IS NOT AN INVOICE!

Please do not use this form for payment remittance.

MARIAH VERHAGEN
Notary Public
State of Wisconsin

BOARD OF SUPERVISORS MEETING DATES SWEETWATER CREEK COMMUNITY DEVELOPMENT DISTRICT FISCAL YEAR 2025

The Board of Supervisors of the Sweetwater Creek Community Development District will hold their regular meetings for Fiscal Year 2025 at 1865 N. Loop Parkway, St. Augustine, FL 32095 at 4:00 p.m. on the first Thursday of each month, unless otherwise indicated as follows:

October 3, 2024
November 7, 2024
December 5, 2024
January 9, 2025
(*Second Thursday)
February 6, 2025
March 6, 2025
April 3, 2025
May 1, 2025
June 5, 2025
July 10, 2025 (*Second Thursday)
August 7, 2025
September 4, 2025

The meetings are open to the public and will be conducted in accordance with the provision of Florida Law for Community Development Districts. The meetings may be continued to a date, time, and place to be specified on the record at the meeting. A copy of the agenda for these meetings may be obtained from Governmental Management Services, LLC, 475 West Town Place, Suite 114, St. Augustine, Florida 32092, (904) 940-5850, or by visiting the District's website at www.SweetwaterCreekCDD.com.

There may be occasions when one or more Supervisors or staff will participate by telephone. Pursuant to provisions of the Americans with Disabilities Act, any person requiring special accommodations of this meeting because of a disability or physical impairment should contact the District Office at (904) 940-5850 at least 48 hours prior to the meeting. If you are hearing or speech impaired, please contact the Florida Relay Service by dialing 7-1-1, or 1-800-955-8771 (TTY) / 1-800-955-8770 (Voice), for aid in contacting the District Office.

A person who decides to appeal any decision made at the meeting with respect to any matter considered at the meeting is advised that person will need a record of the proceedings and that accordingly, the person may need to ensure that a verbatim record of the proceedings is made, including the testimony and evidence upon which such appeal is to be based.
Jim Oliver
District Manager
Pub: Aug 29, 2024; #10489443



Duval Landscape Maintenance
 7011 Business Park Blvd N
 Jacksonville, FL 32256
 www.duvallandscape.com

INVOICE

| | |
|--------------|--------------------|
| Date | Invoice No. |
| 07/25/24 | 27963 |
| Terms | Due Date |
| Net 40 | 09/03/24 |

| BILL TO |
|---|
| Sweetwater Community Development District 475 West Town Place, Suite 114 |

| PROPERTY |
|--|
| Sweetwater Creek CDD 605 Palencia Club Dr |

| | |
|-------------------|------------------|
| Amount Due | PO Number |
| \$2,500.00 | |

Please detach top portion and return with your payment.

| DESCRIPTION | UOM | QTY | UNIT PRICE | EXT PRICE | TOTAL |
|-------------|-----|-----|------------|-----------|-------|
|-------------|-----|-----|------------|-----------|-------|

#32806 - Module repairs July 24

Repair both two wire modules for
 barbella and middle las colinas
 controllers

| | | | | | |
|---|----|------|------------|------------|-------------------|
| Irrigation Service/Repairs | | | | | \$2,500.00 |
| Hunter ACC2 Expansion Module 75 station | 1 | 2.00 | \$1,200.00 | \$2,400.00 | |
| Irrigation Labor | Hr | 1.00 | \$100.00 | \$100.00 | |

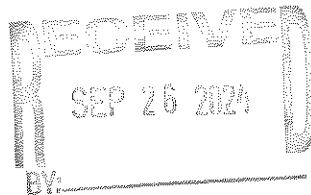

| | |
|--------------------|-------------------|
| Total | \$2,500.00 |
| Payments/Credits | (\$0.00) |
| Balance Due | \$2,500.00 |

Irrigation repair and maint
 1.320.53800.47300
 DW
 9/26/24



Duval Landscape Maintenance
 7011 Business Park Blvd N
 Jacksonville, FL 32256
 www.duvallandscape.com

INVOICE

| Date | Invoice No. |
|----------|-------------|
| 07/29/24 | 27995 |
| Terms | Due Date |
| Net 40 | 09/07/24 |

| BILL TO |
|---|
| Sweetwater Community Development District 475 West Town Place, Suite 114 |

| PROPERTY |
|--|
| Sweetwater Creek CDD 605 Palencia Club Dr |

| Amount Due | PO Number |
|------------|-----------|
| \$1,028.70 | |

Please detach top portion and return with your payment.

| DESCRIPTION | UOM | QTY | UNIT PRICE | EXT PRICE | TOTAL |
|-------------|-----|-----|------------|-----------|-------|
|-------------|-----|-----|------------|-----------|-------|

#32834 - Remove Fabric from Drains

Remove the grate covers and remove fabric from 4 drains (one drain along walkway between 62 and 78 Rincon on right, three other drains in preserve starting behind 88 Rincon, see attached photos of these drains), then reinstall drain covers.

Remove fabric from site.

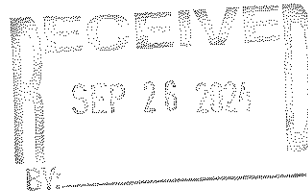

| | | | | | |
|-----------------------------------|----|-------|---------|------------|-------------------|
| Enhancement/Extra Services | | | | | \$1,028.70 |
| Enhancement Labor | Hr | 12.00 | \$85.73 | \$1,028.70 | |

Landscape maint and material
 1.320.53800.46200
 DW
 9/26/24

| | |
|--------------------|-------------------|
| Total | \$1,028.70 |
| Payments/Credits | (\$0.00) |
| Balance Due | \$1,028.70 |



Duval Landscape Maintenance
 7011 Business Park Blvd N
 Jacksonville, FL 32256
 www.duvallandscape.com

INVOICE

| Date | Invoice No. |
|----------|-------------|
| 09/18/24 | 28615 |
| Terms | Due Date |
| Net 40 | 10/28/24 |

| BILL TO |
|---|
| Sweetwater Community Development District 475 West Town Place, Suite 114 |

| PROPERTY |
|--|
| Sweetwater Creek CDD 605 Palencia Club Dr |

| Amount Due | PO Number |
|------------|-----------|
| \$2,200.00 | |

Please detach top portion and return with your payment.

| DESCRIPTION | UOM | QTY | UNIT PRICE | EXT PRICE | TOTAL |
|-------------|-----|-----|------------|-----------|-------|
|-------------|-----|-----|------------|-----------|-------|

#33604 - Subscription renewal Sept 24

Subscription renewal

| | | | | | |
|-----------------------------------|--|-------|----------|------------|-------------------|
| Irrigation Service/Repairs | | | | | \$2,200.00 |
| Hunter Subscription renewal | | 11.00 | \$200.00 | \$2,200.00 | |

| | |
|--------------------|-------------------|
| Total | \$2,200.00 |
| Payments/Credits | (\$0.00) |
| Balance Due | \$2,200.00 |

Irrigation repair and maint
 1.320.53800.47300
 DW
 9/25/24

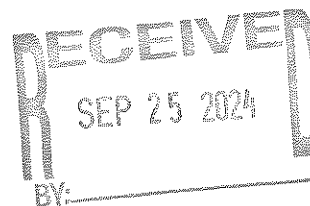

Governmental Management Services, LLC

1001 Bradford Way
Kingston, TN 37763

Invoice

Invoice #: 162
Invoice Date: 9/15/24
Due Date: 9/15/24
Case:
P.O. Number:

Bill To:

Sweetwater Creek CDD
475 West Town Place
Suite 114
St. Augustine, FL 32092

| Description | Hours/Qty | Rate | Amount |
|---|-----------|----------|------------|
| Assessment Roll Certification - FY 2025 | | 5,200.00 | 5,200.00 |
| Total | | | \$5,200.00 |
| Payments/Credits | | | \$0.00 |
| Balance Due | | | \$5,200.00 |

RECEIVED
SEP 19 2024
BY: _____

Project Manager Alex Acree



Governmental Management Services
James Oliver
475 West Town Place
St. Augustine, FL 32092

July 10, 2024
Invoice # 191465

Project 0000021856.000 Sweetwater Creek CDD

This invoice includes charges for tasks performed for your project, including:

- Coordination with District Manager
- CDD Meeting
- Rincon Drive Drainage Coordination
- CUP Meter Readings (June)
- Prepare Requisitions



Please call Alex Acree if you have any questions or concerns regarding your project. For billing inquiries, please contact our Accounting Department.

Professional Services through June 30, 2024

Phase 0001 Engineering Services

| | Hours | Rate | Amount |
|------------------------------|-------|--------|-----------------|
| Vice President of Production | 2.25 | 290.00 | 652.50 |
| Sr. Construction Inspector | .50 | 210.00 | 105.00 |
| Project Coordinator 2 | 1.00 | 100.00 | 100.00 |
| Project Administrator | .25 | 120.00 | 30.00 |
| Project Surveyor | 3.00 | 155.00 | 465.00 |
| Total Labor | | | 1,352.50 |

Phase 0999 Reimbursable Expenses

Reimbursable Expenses

| | | | |
|----------------------------|--|--|--------------|
| Mileage | | | 18.49 |
| Total Reimbursables | | | 18.49 |

| | | | |
|----------------------------|--------------------|--|-------------|
| Color 8.5 x 11 | 13.0 Copies @ 0.50 | | 6.50 |
| Total Reproductions | | | 6.50 |

Total Due: 1,377.49

Billed to Date

| | Current Due | Prior Billed | Billed to Date |
|---------|-------------|--------------|----------------|
| Labor | 1,352.50 | 8,111.25 | 9,463.75 |
| Expense | 18.49 | 80.90 | 99.39 |

7 Waldo Street, St. Augustine, FL 32084 | P: 904.826.1334 | F: 904.826.4547 | www.MDGinc.com

Invoices are due upon receipt. Prompt payments are critical to keeping your project on schedule. Matthews | DCCM accepts all major credit cards for a 3.5% convenience fee. Payments not received within 30 days of the invoice date are considered past due and all work and submittals will be placed on hold until payment is received along with finance charges of 18% annual accrued. We appreciate your business and cooperation with timely payments.

| | | | | | |
|---------------|----------------|----------------------|-----------------|-----------------|--------|
| Project | 0000021856.000 | Sweetwater Creek CDD | | Invoice | 191465 |
| Unit | | 6.50 | 19.42 | 25.92 | |
| Totals | | 1,377.49 | 8,211.57 | 9,589.06 | |

7 Waldo Street, St. Augustine, FL 32084 | P: 904.826.1334 | F: 904.826.4547 | www.MDGinc.com

Invoices are due upon receipt. Prompt payments are critical to keeping your project on schedule. Matthews I DCCM accepts all major credit cards for a 3.5% convenience fee. **Payments not received within 30 days of the invoice date are considered past due and all work and submittals will be placed on hold until payment is received along with finance charges of 18% annual accrued.**
 We appreciate your business and cooperation with timely payments.



Invoice

| | |
|--------------|-------------------|
| Date: | Invoice #: |
| 10/8/2024 | 185748 |

1702 Lindsey Road
 Jacksonville, FL 32221-6791
 Office 904-781-7060

| | |
|--|----------------------------------|
| Bill To | |
| Sweetwater Creek CDD 475 West Town Place Suite 114 Riverside Management Services St. Augustine, FL 32092-3649 | |
| Email bperegrino@gmsnf.com | Terms Due Upon Receipt |

| | | |
|---|-------------------------------|-----------------------------|
| Work Performed At | | |
| Sweetwater Creek CDD 1187 Las Calinas Blvd. St. Augustine, FL 32095 Dan Wright | | |
| Purchase Order | Rep PM SCOTT HAINES | Work Order 242312 |

| Item | Description | Amount |
|------|---|------------|
| | Final Billing Las Calinas HOA Attn: Dan Wright - Management 9 3 24 Re: concrete repairs - >level the dirt and compact where the city removed the sidewalk at the entry to the property >form and pour new concrete sidewalk 46ft x 5ft wide x 4" thick using 3000 psi with a lite broom finish >strip the forms and cut joints in new concrete as needed >clean up job and haul away debris Total \$4,370.00 | \$4,370.00 |

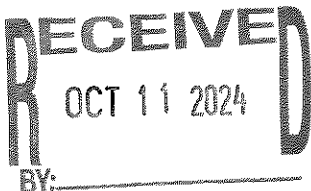

1.320.53800.47301
 Field repairs and maintenance
 DW
 10/11/24

ALL WORK WAS INSPECTED AND PERFORMED IN A PROFESSIONAL MANNER. All material is guaranteed to be as specified, and the above work was completed in a substantial workmanlike manner. This is a full invoice due and payable by above due date in accordance with our agreement. Late charges will be assessed thereafter due date listed above at a rate of 1.5% per month. All disputes are to be submitted in writing by mail, fax or email within 30 days from invoice date. You further agree to waive any right to jury trial in any action relating to these services or the payment thereof. In any action to collect past due amounts, customer shall pay all reasonable attorney's fees incurred.

| | |
|------------------------------|------------|
| Subtotal: | \$4,370.00 |
| Sales Tax: | \$0.00 |
| Invoice Total: | \$4,370.00 |
| Payments and Credits: | \$0.00 |
| Total Due: | \$4,370.00 |



| | | | |
|---|--|--|-------------------------|
| ACCOUNT NAME Sweetwater Creek Cdd/Gms | | ACCOUNT # 764151 | PAGE # 1 of 1 |
| INVOICE # 0006583534 | BILLING PERIOD Jul 1- Jul 31, 2024 | PAYMENT DUE DATE August 20, 2024 | |
| PREPAY (Memo info) \$0.00 | UNAPPLIED (included in amt due) \$0.00 | TOTAL CASH AMT DUE* \$1,375.23 | |

BILLING ACCOUNT NAME AND ADDRESS

Sweetwater Creek Cdd/Gms
475 West Town Place, Suite 114
Saint Augustine, FL 32092

Legal Entity: Gannett Media Corp.
Terms and Conditions: Past due accounts are subject to interest at the rate of 18% per annum or the maximum legal rate (whichever is less). Advertiser claims for a credit related to rates incorrectly invoiced or paid must be submitted in writing to Publisher within 30 days of the invoice date or the claim will be waived. Any credit towards future advertising must be used within 30 days of issuance or the credit will be forfeited.
All funds payable in US dollars.

BILLING INQUIRIES/ADDRESS CHANGES 1-877-736-7612 or smb@ccc.gannett.com **FEDERAL ID** 47-2390983

To sign-up for E-mailed invoices and online payments please contact abgspecial@gannett.com.

| Date | Description | Amount |
|--------|---------------------|----------|
| 7/1/24 | Balance Forward | \$65.92 |
| 7/9/24 | PAYMENT - THANK YOU | -\$65.92 |

Legal Advertising:

| Date range | Product | Order Number | Description | PO Number | Runs | Ad Size | Net Amount |
|-----------------|-------------------------|--------------|-------------------------------------|-----------|------|-------------------|------------|
| 7/12/24-7/19/24 | SAG St Augustine Record | 10367114 | FY 2025 Budget Notice Hearing w/map | | 2 | 3.0000 x 17.75 in | \$1,182.19 |

Package Advertising:

| Start-End Date | Order Number | Product | Description | PO Number | Package Cost |
|----------------|--------------|-------------------------|--------------------------------|-----------|--------------|
| 7/16/24 | 10350522 | SAG St Augustine Record | Sweetwater Creek Joint Meeting | | \$102.64 |
| 7/29/24 | 10413992 | SAG St Augustine Record | 8/5 Meeting | | \$90.40 |



As an incentive for customers, we provide a discount off the total invoice cost equal to the 3.99% service fee if you pay with Cash/Check/ACH. Pay by Cash/Check/ACH and Save!

| | |
|-----------------------------------|------------|
| Total Cash Amount Due | \$1,375.23 |
| Service Fee 3.99% | \$54.87 |
| *Cash/Check/ACH Discount | -\$54.87 |
| *Payment Amount by Cash/Check/ACH | \$1,375.23 |
| Payment Amount by Credit Card | \$1,430.10 |

PLEASE DETACH AND RETURN THIS PORTION WITH YOUR PAYMENT

| | | | | | | |
|---|-----------------------------------|-----------------------------------|-----------------------------------|--|-------------------------------------|--|
| ACCOUNT NAME Sweetwater Creek Cdd/Gms | | ACCOUNT NUMBER 764151 | | INVOICE NUMBER 0006583534 | | AMOUNT PAID \$1,375.23 |
| CURRENT DUE \$1,375.23 | 30 DAYS PAST DUE \$0.00 | 60 DAYS PAST DUE \$0.00 | 90 DAYS PAST DUE \$0.00 | 120+ DAYS PAST DUE \$0.00 | UNAPPLIED PAYMENTS \$0.00 | TOTAL CASH AMT DUE* \$1,375.23 |
| REMITTANCE ADDRESS (Include Account# & Invoice# on check) Gannett Florida LocaliQ PO Box 631244 Cincinnati, OH 45263-1244 | | | | TO PAY WITH CREDIT CARD PLEASE CALL: 1-877-736-7612 | | TOTAL CREDIT CARD AMT DUE \$1,430.10 |
| | | | | To sign up for E-mailed invoices and online payments please contact abgspecial@gannett.com | | |

00007641510000000000000065835340013752367171

LOCALIQ FLORIDA

PO Box 631244 Cincinnati, OH 45263-1244

AFFIDAVIT OF PUBLICATION

Courtney Hogge
Sweetwater Creek Cdd/Gms
475 West Town Place, Suite 114

Saint Augustine FL 32092

STATE OF WISCONSIN, COUNTY OF BROWN

Before the undersigned authority personally appeared, who on oath says that he or she is the Legal Coordinator of the St Augustine Record, published in St Johns County, Florida; that the attached copy of advertisement, being a Main Legal CLEGL, was published on the publicly accessible website of St Johns County, Florida, or in a newspaper by print in the issues of, on:

07/12/2024, 07/19/2024

Affiant further says that the website or newspaper complies with all legal requirements for publication in chapter 50, Florida Statutes.

Subscribed and sworn to before me, by the legal clerk, who is personally known to me, on 07/19/2024

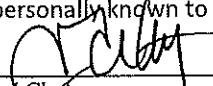

Legal Clerk



Notary, State of WI, County of Brown

8.25.26

My commission expires

| | | |
|-------------------|-----------|--------------|
| Publication Cost: | \$1182.19 | |
| Tax Amount: | \$0.00 | |
| Payment Cost: | \$1182.19 | |
| Order No: | 10367114 | # of Copies: |
| Customer No: | 764151 | 0 |
| PO #: | | |

THIS IS NOT AN INVOICE!

Please do not use this form for payment remittance.

MARIAH VERHAGEN
Notary Public
State of Wisconsin



**SWEETWATER CREEK COMMUNITY
DEVELOPMENT DISTRICT**

NOTICE OF PUBLIC HEARING TO CONSIDER THE ADOPTION OF THE FISCAL YEAR 2025 BUDGET; NOTICE OF PUBLIC HEARING TO CONSIDER THE IMPOSITION OF OPERATIONS AND MAINTENANCE SPECIAL ASSESSMENTS, ADOPTION OF AN ASSESSMENT ROLL, AND THE Levy, COLLECTION, AND ENFORCEMENT OF THE SAME; AND NOTICE OF REGULAR BOARD OF SUPERVISORS MEETING.

Upcoming Public Hearings and Regular Meeting

The Board of Supervisors ("Board") for the Sweetwater Creek Community Development District ("District") will hold the following two public hearings and a regular meeting:

DATE: August 8, 2024
 TIME: 4:00 p.m.
 LOCATION: 1823 N. Loop Parkway
 St. Augustine, Florida
 32093

The first public hearing is being held pursuant to Chapter 190, Florida Statutes, to receive public comment and objections on the District's proposed budget ("Proposed Budget") for the fiscal year beginning October 1, 2024, and ending September 30, 2025 ("Fiscal Year 2025"). The second public hearing is being held pursuant to Chapters 190 and 197, Florida Statutes, to consider the imposition of operations and maintenance special assessments ("OM Assessments") upon the lands located within the District, to fund the Proposed Budget for Fiscal Year 2025; to consider the adoption of an assessment roll; and, to provide for the levy, collection, and enforcement of assessments. At the conclusion of the hearings, the Board will, by resolution, adopt a budget and levy OM Assessments as finally approved by the Board. A Board meeting of the District will also be held where the Board may transact any other District business.

Description of Assessments

The District imposes OM Assessments on benefited property within the District for the purpose of funding the District's general administrative, operations, and maintenance budget. A geographic depiction of the property potentially subject to the proposed OM Assessments is identified in the map attached hereto. The table below shows the schedule of the proposed OM Assessments, which are subject to change at the hearing:

| Land Use | Total # of Units / Acres | ERU* Factor | Proposed OM Assessment (including collection costs / early payment discounts) |
|-------------------------------|--------------------------|-------------|---|
| City Units Lot | 160 | 1.01 | \$2,451.95 |
| 16-27 Lot | 166 | 1.16 | \$2,843.57 |
| 181-83 Lot | 42 | 1.41 | \$3,431.01 |
| 20 Lot | 4 | 1.43 | \$3,505.44 |
| March (Less than 15K sq ft) | 6 | 1.43 | \$3,431.01 |
| March (15K-20K sq ft) | 35 | 1.43 | \$5,002.44 |
| March (20K and greater sq ft) | 4 | 1.43 | \$3,577.04 |
| McConn Lots | 8 | 1.39 | \$3,397.66 |

The proposed OM Assessments as stated include collection costs and/or early payment discounts, which St. Johns County ("County") may impose on assessments that are collected as the County tax bill. Moreover, pursuant to Section 197.96(2)(4), Florida Statutes, the full amount shall serve as the "maximum rate" authorized by law for OM Assessments, such that no assessment hearing shall be held or notice provided in future years unless the assessments are proposed to be increased or another criterion within Section 197.96(2)(1), Florida Statutes, is met. Note that the OM Assessments do not include any debt service assessments previously levied by the District that are due to be collected for Fiscal Year 2025.

For Fiscal Year 2025, the District intends to have the County tax collector collect the assessments imposed on certain developed property. It is important to pay your assessment because failure to pay will cause a tax certificate to be issued against the property which may result in loss of title, or for direct billed assessments, may result in a foreclosure action, which also may result in a loss of title. The District's decision to collect assessments on the tax roll or by direct billing does not preclude the District from later electing to collect those or other assessments in a different manner at a future time.

Additional Provisions

The public hearings and meetings are open to the public and will be conducted in accordance with the provisions of Florida law. A copy of the Proposed Budget, proposed assessment roll, and the agenda for the hearings and meeting may be obtained at the office of the District Manager, located at 474 West Town Place, Suite 114, St. Augustine, Florida 32092. Ph: (904) 940-3820 ("District Manager's Office"), during normal business hours. The public hearings and meeting may be continued to a date, time, and place to be specified on the record at the hearings or meeting. There may be occasions when staff or board members may participate by speaker telephone.

Any person requiring special accommodations at this meeting because of a disability or physical impairment should contact the District Manager's Office at least forty-eight (48) hours prior to the meeting. If you are hearing or speech impaired, please contact the Florida Relay Service by dialing 7-1-1, or 1-800-935-8771 (TTY) / 1-800-935-8770 (Voice), for aid in contacting the District Manager's Office.

Please note that all affected property owners have the right to appear at the public hearings and meeting and may also file written objections with the District Manager's Office within twenty days of publication of this notice. Each person who decides to appeal any decision made by the Board with respect to any matter considered at the public hearings or meeting is advised that person will need a record of proceedings and that accordingly, the person may need to ensure that a verbatim record of the proceedings is made, including the testimony and evidence upon which such appeal is to be based.

District Manager

PLATE 1

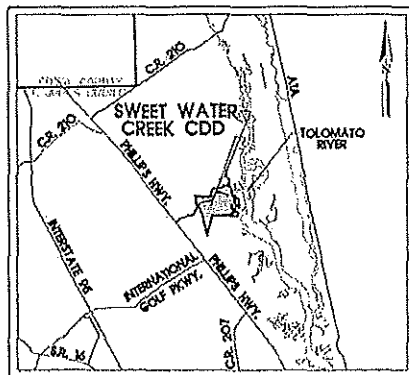

LOCATION MAP

SWEETWATER CREEK CDD

ST. JOHN'S, FLORIDA

FILE NO. 25-02-15
 CASE NO. 25-02-15
 DATE: JUNE 26, 2025
 OF 1-10 P. 1

LOCALIQ FLORIDA

PO Box 631244 Cincinnati, OH 45263-1244

AFFIDAVIT OF PUBLICATION

Courtney Hogge
Sweetwater Creek Cdd/Gms
475 West Town Place, Suite 114

Saint Augustine FL 32092

STATE OF WISCONSIN, COUNTY OF BROWN

Before the undersigned authority personally appeared, who on oath says that he or she is the Legal Coordinator of the St Augustine Record, published in St Johns County, Florida; that the attached copy of advertisement, being a Public Notices, was published on the publicly accessible website of St Johns County, Florida, or in a newspaper by print in the issues of, on:

07/16/2024

Affiant further says that the website or newspaper complies with all legal requirements for publication in chapter 50, Florida Statutes.

Subscribed and sworn to before me, by the legal clerk, who is personally known to me, on 07/16/2024

Legal Clerk

Keegan Horan
[Signature]

Notary, State of WI, County of Brown

8.25.26

My commission expires

Publication Cost: \$102.64
Tax Amount: \$0.00
Payment Cost: \$102.64
Order No: 10350522
Customer No: 764151
PO #:

of Copies:
1

THIS IS NOT AN INVOICE!

Please do not use this form for payment remittance.

MARIAH VERHAGEN
Notary Public
State of Wisconsin

SWEETWATER CREEK COMMUNITY DEVELOPMENT DISTRICT AND MARSHALL CREEK COMMUNITY DEVELOPMENT DISTRICT NOTICE OF SPECIAL MEETING OF THE BOARD OF SUPERVISORS

The Board of Supervisors of the Sweetwater Creek Community Development District ("Sweetwater Creek") and Marshall Creek Community Development District ("Marshall Creek") will hold a joint special meeting on July 30, 2024 at 4:00 PM at the Marshall Creek Amenity Center, 625 Palencia Club Drive, St. Augustine, Florida 32095, the purpose of holding a joint session with Marshall Creek regarding the Interlocal Agreement between Sweetwater Creek and Marshall Creek and other matters of interest to both community development districts. A copy of the agenda may be obtained by contacting the offices of the Sweetwater Creek District Manager, Governmental Management Services, LLC, 475 West Town Place, Ste. 114, St. Augustine, Florida, Attn: Jim Oliver (joliver@gmsnf.com) Telephone: (904) 940-5850 x406 ("District Office"), during normal business hours, or by visiting the District's website, sweetwatercreekcdd.com. The meeting is open to the public and will be conducted in accordance with the provisions of Florida law for community development districts. The meeting may be continued to a date, time, and place to be specified on the record of the meeting.

There may be occasions when staff may participate by speaker telephone or remote video technology. Any person requiring special accommodations at this meeting because of a disability or physical impairment should contact the District Office at (904) 940-5850 x406 at least three business days prior to the meeting. If you are hearing or speech impaired, please contact the Florida Relay Service at 1-800-955-8770, for aid in contacting the District Office.

Each person who decides to appeal any decision made by the Board with respect to any matter considered at the public hearing or meeting is advised that person will need a record of proceedings and that accordingly, the person may need to ensure that a verbatim record of the proceedings is made, including the testimony and evidence upon which such appeal is to be based.

Jim Oliver,
District Manager
#10350522; 7/16/2024

LOCALIQ FLORIDA

PO Box 631244 Cincinnati, OH 45263-1244

AFFIDAVIT OF PUBLICATION

Courtney Hogge
Sweetwater Creek Cdd/Gms
475 West Town Place, Suite 114

Saint Augustine FL 32092

STATE OF WISCONSIN, COUNTY OF BROWN

Before the undersigned authority personally appeared, who on oath says that he or she is the Legal Coordinator of the St Augustine Record, published in St Johns County, Florida; that the attached copy of advertisement, being a Public Notices, was published on the publicly accessible website of St Johns County, Florida, or in a newspaper by print in the issues of, on:

07/29/2024

Affiant further says that the website or newspaper complies with all legal requirements for publication in chapter 50, Florida Statutes.

Subscribed and sworn to before me, by the legal clerk, who is personally known to me, on 07/29/2024

Legal Clerk

Notary, State of WI, County of Brown

My commission expires

| | | |
|-------------------|----------|--------------|
| Publication Cost: | \$90.40 | |
| Tax Amount: | \$0.00 | |
| Payment Cost: | \$90.40 | |
| Order No: | 10413992 | # of Copies: |
| Customer No: | 764151 | 1 |
| PO #: | | |

THIS IS NOT AN INVOICE!

Please do not use this form for payment remittance.

MARIAH VERHAGEN
Notary Public
State of Wisconsin

SWEETWATER CREEK COMMUNITY DEVELOPMENT DISTRICT NOTICE OF WORKSHOP

Notice is hereby given that a Workshop of one or more members of the Board of Supervisors ("Board") of the Sweetwater Creek Community Development District ("District") will be held on Monday, August 5, 2024 at 4:00 p.m., at 1865 N. Loop Parkway, St. Augustine, Florida 32095. This Workshop is being held to discuss matters related to the District's landscaping.

An electronic copy of the agenda for the Workshop may be obtained from the District Manager's Office at 475 West Town Place, Suite 114, St. Augustine, Florida 32092, (904) 940-5850, or by email, hmcgaffney@gmsnf.com, during normal business hours and will also be available on the District's website, www.SweetwaterCreekCDD.com at least seven days prior to the workshop.

The Workshop is open to the public and will be conducted in accordance with the provisions of Florida law for community development districts. The Workshop may be continued to a date, time, and place to be specified on the record at such Workshop. There may be occasions when one or more Supervisors, Staff or other individuals will participate by speaker telephone or communications media technology.

Any person requiring special accommodations at the Workshop because of a disability or physical impairment should contact the District Manager's Office at least forty-eight (48) hours prior to each respective meeting. If you are hearing or speech impaired, please contact the Florida Relay Service by dialing 7-1-1, or 1-800-955-8771 (TTY) / 1-800-955-8770 (Voice), for aid in contacting the District Manager's Office.

Each person who decides to appeal any decision made by the Board with respect to any matter considered at the Workshop is advised that person will need a record of proceedings and that accordingly, the person may need to ensure that a verbatim record of the proceedings is made, including the testimony and evidence upon which such appeal is to be based.

Jim Oliver
District Manager
#10413992; 7/29/2024



Duval Landscape Maintenance
 7011 Business Park Blvd N
 Jacksonville, FL 32256
 www.duvallandscape.com

INVOICE

| Date | Invoice No. |
|----------|-------------|
| 10/01/24 | 28887 |
| Terms | Due Date |
| Net 40 | 11/10/24 |

| BILL TO |
|--|
| Sweetwater Community Development District 475 West Town Place, Suite 114 St. Augustine, FL 32095 |

| PROPERTY |
|---|
| Sweetwater Creek CDD 605 Palencia Club Dr St. Augustine, FL 32095 |

| Amount Due | PO Number |
|-------------|-----------|
| \$24,273.00 | |

Please detach top portion and return with your payment.

| DESCRIPTION | UOM | QTY | UNIT PRICE | EXT PRICE | TOTAL |
|--|-----|-----|------------|-----------|-------------|
| #33890 - Palencia- RENEWAL 2024/2025 October 2024 | | | | | \$24,273.00 |

Monthly Breakdown

- Monthly Landscape- Mowing, edging, blowing, trimming /detail- \$20,091.48
- Fertilization- \$1,630.00
- Bedding Plants (ANNUALS)- \$1,915.50
- Irrigation check- \$636.00
-

Bed Dressing / Pinestraw

(billed at time of service)

- Fall install \$25,000.00
- Spring Install \$25,000.00

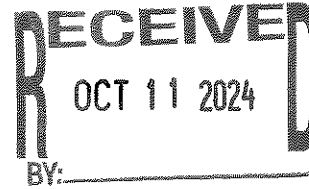

| | |
|--------------------|--------------------|
| Total | \$24,273.00 |
| Payments/Credits | (\$0.00) |
| Balance Due | \$24,273.00 |

INVOICE



| | |
|-------------------------|---|
| Customer | Sweetwater Creek Community Development District |
| Acct # | 189 |
| Date | 08/23/2024 |
| Customer Service | Kristina Rudez |
| Page | 1 of 1 |

Sweetwater Creek Community Development District
 c/o Governmental Management Services
 219 E Livingston St
 Orlando, FL 32801

| Payment Information | |
|------------------------|---------------|
| Invoice Summary | \$ 850.00 |
| Payment Amount | |
| Payment for | Invoice#24666 |
| WC100124522 | |

Thank You

Please detach and return with payment



Customer: Sweetwater Creek Community Development District

| Invoice | Effective | Transaction | Description | Amount |
|---------|------------|--------------|---|------------------|
| 24666 | 10/01/2024 | Renew policy | Policy #WC100124522 10/01/2024-10/01/2025 FIA WC Workers Compensation - Renew policy TRIA & Expense Constant - Renew policy Due Date: 8/23/2024 | 688.50 161.50 |

OCT 07 2024

| |
|--------------|
| Total |
| \$ 850.00 |

Thank You

*FOR PAYMENTS SENT OVERNIGHT:
 Bank of America Lockbox Services, Lockbox 748555, 6000 Feldwood Rd. College Park, GA 30349*

| | | |
|--|--|-------------|
| Remit Payment To: Egis Insurance Advisors P.O. Box 748555 Atlanta, GA 30374-8555 | (321)233-9939 sclirner@egisadvisors.com | Date |
| | | 08/23/2024 |

INVOICE

EverLine Coatings & Services -
Jacksonville
627 Chery St
Neptune Beach, FL 32266

ronvolkmann@everlinecoatings.com
+1 (856) 466-1059



Bill to
Sweetwater Creek CDD

Dan Wright
rmsnf.com
1187 Las Calinas Blvd
St Augustine, Florida

Ship to
Dan Wright
rmsnf.com
1187 Las Calinas Blvd
St Augustine, Florida

Invoice details

Invoice no.: 1132
Terms: Net 15
Invoice date: 10/11/2024
Due date: 10/26/2024

| # | Date | Product or service | Description | Qty | Rate | Amount |
|----|------------|-----------------------|----------------------|-----|----------|----------|
| 1. | 10/08/2024 | Line Painting-Repaint | Sweetwater Creek CDD | 1 | \$554.00 | \$554.00 |

Total \$554.00

Ways to pay



[View and pay](#)

Field repairs and maintenance
1.320.53800.47301
DW
10/14/24

RECEIVED
OCT 14 2024
BY: _____

Future Horizons, Inc

403 N First Street
 PO Box 1115
 Hastings, FL 32145
 USA

Voice: 904-692-1187
 Fax: 904-692-1193

INVOICE

Invoice Number: 86187
 Invoice Date: Sep 30, 2024
 Page: 1

| Bill To: |
|---|
| Sweetwater Creek CDD in N Palencia c/o GMS, LLC 135 West Central Blvd, Ste 320 Orlando, FL 32801 |

| Ship to: |
|---|
| Sweetwater Creek CDD c/o GMS, LLC 135 West Central Blvd, Ste 320 Orlando, FL 32801 |

| Customer ID | Customer PO | Payment Terms | |
|--------------|-----------------|---------------|----------|
| Palencia01 | Per Contract | Net 45 Days | |
| Sales Rep ID | Shipping Method | Ship Date | Due Date |
| | Hand Deliver | | 11/14/24 |

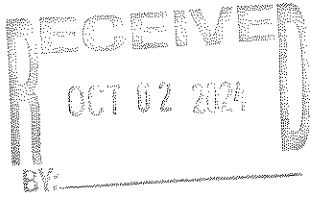
| Quantity | Item | Description | Unit Price | Amount |
|----------|----------------------|--|------------|----------|
| 1.00 | Aquatic Weed Control | Aquatic Weed Control services performed September 9, 12, 24, 2024  Lake Manint 1.320.53800.4700 10/2/24 DW | 2,122.44 | 2,122.44 |

| | |
|------------------------|-----------------|
| Subtotal | 2,122.44 |
| Sales Tax | |
| Freight | |
| Total Invoice Amount | 2,122.44 |
| Payment/Credit Applied | |
| TOTAL | 2,122.44 |

Check/Credit Memo No:

Overdue invoices are subject to finance charges.

Governmental Management Services, LLC
 1001 Bradford Way
 Kingston, TN 37763

Invoice

Invoice #: 163
Invoice Date: 10/1/24
Due Date: 10/1/24
Case:
P.O. Number:

Bill To:
 Sweetwater Creek CDD
 475 West Town Place
 Suite 114
 St. Augustine, FL 32092

| Description | Hours/Qty | Rate | Amount |
|---|-----------|----------|----------|
| Management Fees -October 2024 | | 3,683.33 | 3,683.33 |
| Website Administration -October 2024 | | 86.67 | 86.67 |
| Information Technology - October 2024 | | 123.50 | 123.50 |
| Dissemination Agent Services - October 2024 | | 459.33 | 459.33 |
| Office Supplies | | 22.39 | 22.39 |
| Postage | | 122.14 | 122.14 |
| Copies | | 153.45 | 153.45 |
| Telephone | | 35.87 | 35.87 |
| AMEX Charge - Holiday Inn Express 8/20/24 | | 175.00 | 175.00 |
| Pool Chemicals - Muriatic Acid | | 48.93 | 48.93 |

RECEIVED
 OCT 02 2024
 BY: _____

| | |
|-------------------------|-------------------|
| Total | \$4,910.61 |
| Payments/Credits | \$0.00 |
| Balance Due | \$4,910.61 |



KILINSKI | VAN WYK

Kilinski | Van Wyk PLLC

P.O. Box 6386
Tallahassee, Florida 32314

Sweetwater Creek CDD
475 West Town Place, Suite 114
St. Augustine, FL 32092

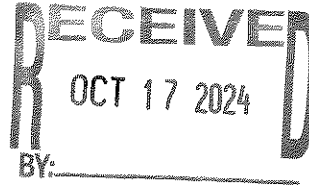

INVOICE

Invoice # 10547
Date: 10/12/2024
Due On: 11/11/2024

Sweetwater Creek CDD -06 Small Claims Court Lawsuit

| Type | Attorney | Date | Notes | Quantity | Rate | Total |
|--------------|----------|------------|--|----------|----------|----------------|
| Service | CD | 09/04/2024 | Review St. John's Clerk website; Telephone call with Judge Christine's Judicial Assistant and update status of file. | 0.30 | \$170.00 | \$51.00 |
| Total | | | | | | \$51.00 |

Detailed Statement of Account

Current Invoice

| Invoice Number | Due On | Amount Due | Payments Received | Balance Due |
|---------------------------------|------------|------------|-------------------|----------------|
| 10547 | 11/11/2024 | \$51.00 | \$0.00 | \$51.00 |
| Outstanding Balance | | | | \$51.00 |
| Total Amount Outstanding | | | | \$51.00 |

Please make all amounts payable to: Kilinski | Van Wyk PLLC

Please pay within 30 days.



KILINSKI | VAN WYK

Kilinski | Van Wyk PLLC

P.O. Box 6386
Tallahassee, Florida 32314

Sweetwater Creek CDD
475 West Town Place, Suite 114
St. Augustine, FL 32092

INVOICE

Invoice # 10545
Date: 10/14/2024
Due On: 11/13/2024

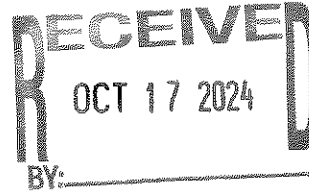

SWEETWATER CREEK CDD – GENERAL COUNSEL/MONTHLY MEETING

| Type | Attorney | Date | Notes | Quantity | Rate | Total |
|---------|----------|------------|--|----------|----------|------------|
| Service | JK | 09/03/2024 | Confer with Oliver re: options for a security shade session; review the same | 0.20 | \$310.00 | \$62.00 |
| Service | JK | 09/04/2024 | Review wright correspondence re: sidewalk repair items and presentation for Board consideration; update research/summary of same; review agenda materials, proposals and documentation in preparation for Board meeting | 0.80 | \$310.00 | \$248.00 |
| Service | MGH | 09/04/2024 | Review and analyze agenda package and materials for Board consideration, including meeting minutes, financial reports, proposals, agreements, and related District documents, in preparation for Board meeting; Analyze Florida statutory authority regarding exemptions from public records and Sunshine law requirements for recommendations and consultations related to security systems; Analyze District staff correspondence regarding County projects on District property and remediation responsibilities. | 4.10 | \$265.00 | \$1,086.50 |
| Service | JK | 09/05/2024 | Finalize meeting preparations, including easement review; attend Board meeting; post meeting follow up; review SJC sexual offender ordinance | 2.70 | \$310.00 | \$837.00 |
| Service | CL | 09/05/2024 | Review conveyance documents; Email to Z. Rogers concerning the same. | 0.80 | \$265.00 | \$212.00 |
| Service | MGH | 09/05/2024 | Review and analyze Chairman's draft Fiscal Year 2025 goals for staff; prepare for and | 0.50 | \$265.00 | \$132.50 |

| | | | | | | |
|---------|-----|------------|--|------|----------|----------|
| | | | attend Board meeting; review and analyze St. Johns County Ordinance Nos. 2009-36 (Child Safety Zone Ordinance) and 2023-46 (Amending Child Safety Zone Ordinance) and requirements for designation of Child Safety Zones. | | | |
| Service | MGH | 09/06/2024 | Prepare letter to Marshall Creek CDD regarding proposed amendment to interlocal agreement; finalize and coordinate mailing of same and distribute to Supervisors; analyze status of compliance with statutory Public Facilities Report requirement; confer with JK regarding St. Johns County water main project to take place on District property. | 1.80 | \$265.00 | \$477.00 |
| Service | JK | 09/06/2024 | Review cover letter and attachments for interlocal agreement amendment; finalize same | 0.30 | \$310.00 | \$93.00 |
| Service | CD | 09/06/2024 | Finalize and email letter to Marshall Creek Community Development District | 0.30 | \$170.00 | \$51.00 |
| Service | JK | 09/07/2024 | Confer with district manager re: proposals for irrigation and fencing for ASO/contract work; follow up on county location; follow up with Lennar | 0.20 | \$310.00 | \$62.00 |
| Service | MGH | 09/09/2024 | Review, analyze, and provide comments to Marshall Creek's draft revisions to amenity policies; review and analyze District Manager meeting notes. | 1.40 | \$265.00 | \$371.00 |
| Service | JK | 09/09/2024 | Field call from Marshall Creek on interlocal agreement | 0.20 | \$310.00 | \$62.00 |
| Service | JK | 09/10/2024 | Conference call with Marshall Creek attorney re: interlocal agreement; review updated proposals for maintenance services | 0.30 | \$310.00 | \$93.00 |
| Service | JK | 09/11/2024 | Field call from Supervisor re: resolution on sexual/predator offenders | 0.40 | \$310.00 | \$124.00 |
| Service | MGH | 09/11/2024 | Prepare Additional Services Order with Duval Landscape for irrigation repairs and installation. | 0.70 | \$265.00 | \$185.50 |
| Service | MGH | 09/12/2024 | Preliminary review of Phase Layout and related documents regarding St. Johns County water main project to take place on District property. | 0.30 | \$265.00 | \$79.50 |
| Service | JK | 09/16/2024 | Review Marshall Creek safety zone correspondence and provide framework for Sweetwater on same; review ASO for | 0.40 | \$310.00 | \$124.00 |

| irrigation installation services and provide comments to same | | | | | | |
|---|-----|------------|--|------|----------|-------------------|
| Service | MGH | 09/16/2024 | Review Marshall Creek CDD's provided list of Child Safety Zone designations; further analyze pertinent St. Johns County ordinances, definitions, and requirements relative to same; further prepare Additional Services Order with Duval Landscape for irrigation repairs and installation, including adding warranty provision, and finalize and distribute same. | 0.90 | \$265.00 | \$238.50 |
| Service | MGH | 09/19/2024 | Review draft agenda for October 3, 2024 Board meeting and note legal follow-up items. | 0.20 | \$265.00 | \$53.00 |
| Service | MGH | 09/23/2024 | Review, analyze, and revise draft minutes of the September 5, 2024 Board meeting; review and analyze correspondence and pertinent District documents related to street parking policies. | 0.60 | \$265.00 | \$159.00 |
| Service | JK | 09/23/2024 | Review parking correspondence; review meeting minutes; review change in meeting date/agenda and confer with District staff on same; follow up on SJC ordinance; provide response on HOA/CDD joint matters | 0.70 | \$310.00 | \$217.00 |
| Service | MGH | 09/26/2024 | Review and analyze St. Johns County Official Records, plat maps, conveyance documents, and easements to determine restoration responsibilities and obligations following St. Johns County water main project on District property. | 1.40 | \$265.00 | \$371.00 |
| Total | | | | | | \$5,338.50 |

Detailed Statement of Account

Current Invoice

| Invoice Number | Due On | Amount Due | Payments Received | Balance Due |
|---------------------------------|------------|------------|-------------------|-------------------|
| 10545 | 11/13/2024 | \$5,338.50 | \$0.00 | \$5,338.50 |
| Outstanding Balance | | | | \$5,338.50 |
| Total Amount Outstanding | | | | \$5,338.50 |

Please make all amounts payable to: Kilinski | Van Wyk PLLC

Please pay within 30 days.

Project Manager Alex Acree



Governmental Management Services
James Oliver
475 West Town Place
St. Augustine, FL 32092

Engineering - Architecture - Planning - Surveying

October 10, 2024
Invoice # 191965

Project 0000021856.0000 Sweetwater Creek CDD

This invoice includes charges for tasks performed for your project, including:

- Coordination with District Manager
- CDD Meeting
- SJC Confirmation Letter
- Coordinate Site Electrical Plans with FPL
- CUP Meter Readings (September)
- Prepare Requisitions

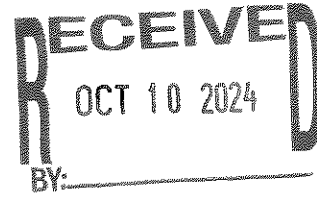

Please call Alex Acree if you have any questions or concerns regarding your project. For billing inquiries, please contact our Accounting Department.

Professional Services through September 30, 2024

Phase 0001 Engineering Services

| | Hours | Rate | Amount |
|------------------------------|-------|-------------------|-----------------|
| Vice President of Production | 2.50 | 290.00 | 725.00 |
| Sr. Construction Inspector | .50 | 210.00 | 105.00 |
| Project Coordinator 2 | 1.50 | 100.00 | 150.00 |
| Project Administrator | 1.00 | 120.00 | 120.00 |
| Inspector | 3.50 | 170.00 | 595.00 |
| Total Labor | | | 1,695.00 |
| | | Total Due: | 1,695.00 |

Outstanding Invoices

| Number | Date | Balance |
|--------------|-----------|-----------------|
| 191858 | 9/12/2024 | 1,377.49 |
| Total | | 1,377.49 |

Billed to Date

| | Current Due | Prior Billed | Billed to Date |
|---------------|-----------------|------------------|------------------|
| Labor | 1,695.00 | 12,833.75 | 14,528.75 |
| Expense | 0.00 | 117.88 | 117.88 |
| Unit | 0.00 | 75.36 | 75.36 |
| Interest | 0.00 | 41.32 | 41.32 |
| Totals | 1,695.00 | 13,068.31 | 14,763.31 |

Riverside Management Services, Inc
9655 Florida Mining Blvd. W
Bldg. 300, Suite 305
Jacksonville, FL 32257

Invoice

Invoice #: 286
Invoice Date: 9/23/2024
Due Date: 9/23/2024
Case:
P.O. Number:

Bill To:
Sweetwater Creek
219 E. Livingston St.
Orlando, FL 32801

| Description | Hours/Qty | Rate | Amount |
|---|-----------|--------|-------------------|
| Facility Maintenance August 1 - August 31, 2024 | | 780.08 | 780.08 |
| Maintenance Supplies | | 281.44 | 281.44 |
| Field Repairs + Maint. 1.320.53800.47301 | | | |
| Total | | | \$1,061.52 |
| Payments/Credits | | | \$0.00 |
| Balance Due | | | \$1,061.52 |

RECEIVED
OCT 02 2024

Jerry Lambert
9-27-24

JP

**SWEET WATER CREEK COMMUNITY DEVELOPMENT DISTRICT
MAINTENANCE BILLABLE HOURS
FOR THE MONTH OF AUGUST 2024**

| <u>Date</u> | <u>Hours</u> | <u>Employee</u> | <u>Description</u> |
|-------------|--------------|-----------------|--|
| 8/1/24 | 2 | T.J. | Removed debris around amenity center, roadways, common areas, sidewalks, playgrounds, mini-golf area and lakes, checked and changed all trash receptacles, blew leaves and debris off pickleball courts, pool deck, mini-golf, sidewalks, pavilion, basketball court and playground, emptied and restocked all dog waste receptacles |
| 8/6/24 | 2 | T.J. | Blew leaves and debris off pickleball courts, pool deck, mini-golf, sidewalks, basketball court, pavilion and playground, removed debris around amenity center, roadways, common areas, sidewalks, playgrounds, mini-golf area and lakes, checked and changed all trash receptacles, emptied and restocked dog waste receptacles |
| 8/8/24 | 2 | T.J. | Removed debris around amenity center, roadways, common areas, sidewalks, playgrounds, mini-golf area and lakes, checked and changed all trash receptacles, blew leaves and debris off pickleball courts, pool deck, mini-golf, sidewalks, pavilion, basketball court and playground, emptied and restocked all dog waste receptacles |
| 8/13/24 | 2 | T.J. | Blew leaves and debris off pickleball courts, pool deck, mini-golf, sidewalks, basketball court, pavilion and playground, removed debris around amenity center, roadways, common areas, sidewalks, playgrounds, mini-golf area and lakes, checked and changed all trash receptacles, emptied and restocked dog waste receptacles |
| 8/15/24 | 2 | T.J. | Removed debris around amenity center, roadways, common areas, sidewalks, playgrounds, mini-golf area and lakes, checked and changed all trash receptacles, blew leaves and debris off pickleball courts, pool deck, mini-golf, sidewalks, pavilion, basketball court and playground, emptied and restocked all dog waste receptacles |
| 8/20/24 | 2 | T.J. | Blew leaves and debris off pickleball courts, pool deck, mini-golf, sidewalks, basketball court, pavilion and playground, removed debris around amenity center, roadways, common areas, sidewalks, playgrounds, mini-golf area and lakes, checked and changed all trash receptacles, emptied and restocked dog waste receptacles |
| 8/22/24 | 2 | T.J. | Removed debris around amenity center, roadways, common areas, sidewalks, playgrounds, mini-golf area and lakes, checked and changed all trash receptacles, blew leaves and debris off pickleball courts, pool deck, mini-golf, sidewalks, pavilion, basketball court and playground, emptied and restocked all dog waste receptacles |
| 8/27/24 | 2 | T.J. | Blew leaves and debris off pickleball courts, pool deck, mini-golf, sidewalks, basketball court, pavilion and playground, removed debris around amenity center, roadways, common areas, sidewalks, playgrounds, mini-golf area and lakes, checked and changed all trash receptacles, emptied and restocked dog waste receptacles |
| 8/29/24 | 2 | T.J. | Removed debris around amenity center, roadways, common areas, sidewalks, playgrounds, mini-golf area and lakes, checked and changed all trash receptacles, blew leaves and debris off pickleball courts, pool deck, mini-golf, sidewalks, pavilion, basketball court and playground, emptied and restocked all dog waste receptacles |

TOTAL 18

MILES 135

*Mileage is reimbursable per section 112.061 Florida Statutes Mileage Rate 2009-0.445

MAINTENANCE BILLABLE PURCHASES

Period Ending 9/05/24

| <u>DISTRICT</u> | <u>DATE</u> | <u>SUPPLIES</u> | <u>PRICE</u> | <u>EMPLOYEE</u> |
|------------------|-------------|-------------------------------|-------------------------------|-----------------|
| SWEETWATER CREEK | 7/24/24 | White Ox Rust Remover (2) | 33.64 | D.W. |
| | 7/24/24 | Concrete Mix | 9.19 | D.W. |
| | 7/26/24 | 3 Screws & 3 Bolts | 13.89 | D.W. |
| | 7/29/24 | Gorilla Glue | 11.01 | D.W. |
| | 7/29/24 | Black Oxide 5/16th Drill Bit | 9.32 | D.W. |
| | 7/29/24 | 1 Fastener | 3.52 | D.W. |
| | 7/30/24 | 1 Screws/Fasteners | 6.50 | D.W. |
| | 7/30/24 | Screw/Fastener | 5.85 | D.W. |
| | 8/1/24 | Waterproof Sealent | 29.37 | D.W. |
| | 8/2/24 | Thread Seal TPE (2) | 3.40 | D.W. |
| | 8/6/24 | Sleeve Anchors 14pk | 17.68 | J.L. |
| | 8/6/24 | Shock Wave Carbide Bit (2) | 23.00 | J.L. |
| | 8/9/24 | 3/8" Concrete Anchors (11) | 29.38 | J.L. |
| | 8/13/24 | GFCI 20a WHt Wall Plug Outlet | 33.05 | D.W. |
| | 8/15/24 | Nylon USA Flag | 52.65 | D.W. |
| | | TOTAL | <u><u>\$281.44</u></u> | |

| CHECK DATE | VEND# | INVOICE DATE | INVOICE | EXPENSED TO YRMO | DPT | ACCT# | SUB | SUBCLASS | VENDOR NAME | STATUS | AMOUNT | CHECK AMOUNT | CHECK # |
|------------|-------|--------------|-------------|------------------|-----|-------|-------|----------|--------------------------------|--------|----------|--------------|---------|
| 10/03/24 | 00129 | 9/13/24 | 09132024 | 202409 | 340 | 53800 | 34500 | | FITNESS CLASS | * | 140.00 | | |
| | | | 9/4-9/13 | | | | | | AMYSUE LONG | | | 140.00 | 002728 |
| 10/03/24 | 00131 | 9/18/24 | 09182024 | 202409 | 340 | 53800 | 34500 | | FITNESS CLASSES | * | 280.00 | | |
| | | | 9/9-9/22 | | | | | | DIANE LAURA STOEVER | | | 280.00 | 002729 |
| 10/03/24 | 00128 | 9/18/24 | 09182024 | 202409 | 340 | 53800 | 34500 | | FITNESS CLASSES | * | 160.00 | | |
| | | | 9/10-9/12 | | | | | | ELIANA N ROQUE | | | 160.00 | 002730 |
| 10/03/24 | 00132 | 9/14/24 | 09142024 | 202409 | 340 | 53800 | 34500 | | FITNESS CLASSES | * | 140.00 | | |
| | | | 9/5-9/14 | | | | | | LAURA CORREA | | | 140.00 | 002731 |
| 10/03/24 | 00127 | 9/15/24 | 09152024 | 202409 | 340 | 53800 | 34500 | | FITNESS CLASSES | * | 450.00 | | |
| | | | 9/2-9/15 | | | | | | LINA HERMEZ | | | 450.00 | 002732 |
| 10/03/24 | 00014 | 8/07/24 | T480-97 | 202408 | 330 | 53800 | 52100 | | DISINFECTANT FITNESS WIPE | * | 1,300.00 | | |
| | | | | | | | | | LLOYD'S EXERCISE EQUIPMENT LLC | | | 1,300.00 | 002733 |
| 10/03/24 | 00014 | 6/19/24 | T480-96 | 202409 | 330 | 53800 | 52100 | | DISINFECTANT FITNESS WIPE | * | 1,040.00 | | |
| | | | | | | | | | LLOYD'S EXERCISE EQUIPMENT LLC | | | 1,040.00 | 002734 |
| 10/03/24 | 00135 | 9/18/24 | 09182024 | 202409 | 340 | 53800 | 34500 | | FITNESS CLASSES | * | 245.00 | | |
| | | | 9/9-9/18 | | | | | | MIRANDA BULGER | | | 245.00 | 002735 |
| 10/03/24 | 00141 | 9/18/24 | 09182024 | 202409 | 340 | 53800 | 34500 | | FITNESS CLASS | * | 70.00 | | |
| | | | 9/9 & 9/16 | | | | | | PATRICIA SCOTT | | | 70.00 | 002736 |
| 10/03/24 | 00019 | 10/01/24 | 13129562 | 202410 | 330 | 53800 | 52002 | | OCT POOL CHEMICALS | * | 2,054.80 | | |
| | | | | | | | | | POOLSURE | | | 2,054.80 | 002737 |
| 10/03/24 | 00138 | 9/18/24 | 09182024 | 202409 | 340 | 53800 | 34500 | | FITNESS CLASS | * | 70.00 | | |
| | | | 9/10 & 9/17 | | | | | | RONALD C. CULLUM | | | 70.00 | 002738 |
| 10/03/24 | 00041 | 8/12/24 | 61941687 | 202408 | 340 | 53800 | 34400 | | AUG PEST CONTROL | * | 81.19 | | |
| | | | | | | | | | TURNER PEST CONTROL LLC | | | 81.19 | 002739 |

SWCC SWEETWATER CRK BPEREGRINO

| CHECK DATE | VEND# |INVOICE..... DATE INVOICE | ...EXPENSED TO... YRMO DPT ACCT# SUB SUBCLASS | VENDOR NAME | STATUS | AMOUNT |CHECK..... AMOUNT # |
|------------|-------|-----------------------------------|--|---|--------|----------|----------------------------|
| 10/03/24 | 00041 | 9/19/24 61954326 | 202409 340-53800-34400 | SEP PEST CONTROL TURNER PEST CONTROL LLC | * | 81.19 | 81.19 002740 |
| 10/03/24 | 00042 | 10/01/24 352506 | 202410 330-53800-48400 | PHONE LINE BURGLARY MONIT VILLAGE KEY & ALARM INC | * | 60.00 | 60.00 002741 |
| 10/24/24 | 00129 | 10/11/24 10112024 | 202410 340-53800-34500 | 10/2-10/11 FITNESS CLASS AMYSUE LONG | * | 105.00 | 105.00 002742 |
| 10/24/24 | 00129 | 9/27/24 09272024 | 202409 340-53800-34500 | 9/18-9/27 FITNESS CLASSES AMYSUE LONG | * | 140.00 | 140.00 002743 |
| 10/24/24 | 00096 | 10/01/24 1233 | 202409 330-53800-44000 | SPIN BIKE LEASE FRANK A FLORI DBA CHAIRMAN'S ENT | * | 513.20 | 513.20 002744 |
| 10/24/24 | 00096 | 10/01/24 1237 | 202410 330-53800-44000 | SPIN BIKE LEASE FRANK A FLORI DBA CHAIRMAN'S ENT | * | 513.20 | 513.20 002745 |
| 10/24/24 | 00131 | 10/14/24 10142024 | 202410 340-53800-34500 | 10/7-10/20 FITNESS CLASS DIANE LAURA STOEVER | * | 360.00 | 360.00 002746 |
| 10/24/24 | 00131 | 10/03/24 10032024 | 202409 340-53800-34500 | 9/23-10/6 FITNESS CLASSES DIANE LAURA STOEVER | * | 320.00 | 320.00 002747 |
| 10/24/24 | 00119 | 10/01/24 28700 | 202410 330-53800-46200 | OCT FITNESS CENTER & DOG DUVAL LANDSCAPING MAINTENANCE | * | 1,963.00 | 1,963.00 002748 |
| 10/24/24 | 00128 | 10/03/24 10032024 | 202410 340-53800-34500 | 10/1-10/16 FITNESS CLASS ELIANA N ROQUE | * | 400.00 | 400.00 002749 |
| 10/24/24 | 00128 | 9/26/24 09262024 | 202409 340-53800-34500 | 9/17-9/26 FITNESS CLASSES ELIANA N ROQUE | * | 360.00 | 360.00 002750 |
| 10/24/24 | 00080 | 10/01/24 746544 | 202410 300-15500-10000 | NOV GATE GRD MONITORING HIDDEN EYES LLC DBA ENVERA SYSTEMS | * | 3,428.05 | 3,428.05 002751 |

SWCC SWEETWATER CRK BPEREGRINO

| CHECK DATE | VEND# | INVOICE DATE | INVOICE | EXPENSED TO YRMO | ACCT# | SUB | SUBCLASS | VENDOR NAME | STATUS | AMOUNT | CHECK AMOUNT | CHECK # |
|------------|-------|--------------|--------------------|------------------|-----------------|-----|----------|--------------------------------|--------|----------|--------------|---------|
| 10/24/24 | 00133 | 10/02/24 | 10022024 | 202409 | 340-53800-34500 | | | HEATHER REBELLA | * | 70.00 | 70.00 | 002752 |
| | | | 9/10 & 9/17 | | | | | FITNESS CLASS | | | | |
| 10/24/24 | 00112 | 4/04/24 | 1625 | 202404 | 330-53800-48100 | | | INTEGRATED ACCESS SOLUTIONS | * | 150.00 | 150.00 | 002753 |
| | | | PICKLEBALL | | | | | GATE REPAIR | | | | |
| 10/24/24 | 00151 | 10/02/24 | 10022024 | 202409 | 340-53800-34500 | | | JOSIE LYNN CARLETON | * | 35.00 | 35.00 | 002754 |
| | | | 9/16 | | | | | FITNESS CLASS | | | | |
| 10/24/24 | 00132 | 9/28/24 | 09282024 | 202409 | 340-53800-34500 | | | LAURA CORREA | * | 105.00 | 105.00 | 002755 |
| | | | 9/19-9/28 | | | | | FITNESS CLASSES | | | | |
| 10/24/24 | 00127 | 9/29/24 | 09292024 | 202409 | 340-53800-34500 | | | LINA HERMEZ | * | 450.00 | 450.00 | 002756 |
| | | | 9/16-9/29 | | | | | FITNESS CLASSES | | | | |
| 10/24/24 | 00014 | 10/01/24 | T480-98 | 202409 | 330-53800-52100 | | | LLOYD'S EXERCISE EQUIPMENT LLC | * | 1,300.00 | 1,300.00 | 002757 |
| | | | DISINFECTANT WIPES | | | | | | | | | |
| 10/24/24 | 00014 | 10/01/24 | T480-99 | 202409 | 330-53800-52100 | | | LLOYD'S EXERCISE EQUIPMENT LLC | * | 1,560.00 | 1,560.00 | 002758 |
| | | | DISINFECTANT WIPES | | | | | | | | | |
| 10/24/24 | 00135 | 10/15/24 | 10152024 | 202410 | 340-53800-34500 | | | MIRANDA BULGER | * | 175.00 | 175.00 | 002759 |
| | | | 10/7-10/16 | | | | | FITNESS CLASS | | | | |
| 10/24/24 | 00135 | 10/02/24 | 10022024 | 202409 | 340-53800-34500 | | | MIRANDA BULGER | * | 245.00 | 245.00 | 002760 |
| | | | 9/23-10/2 | | | | | FITNESS CLASSES | | | | |
| 10/24/24 | 00141 | 10/15/24 | 10152024 | 202410 | 340-53800-34500 | | | PATRICIA SCOTT | * | 70.00 | 70.00 | 002761 |
| | | | 10/7&10/14 | | | | | FITNESS CLASS | | | | |
| 10/24/24 | 00141 | 10/02/24 | 10022024 | 202409 | 340-53800-34500 | | | PATRICIA SCOTT | * | 70.00 | 70.00 | 002762 |
| | | | 9/23 & 9/30 | | | | | FITNESS CLASS | | | | |
| 10/24/24 | 00138 | 10/15/24 | 10152024 | 202410 | 340-53800-34500 | | | RONALD C. CULLUM | * | 105.00 | 105.00 | 002763 |
| | | | 10/1-10/8 | | | | | FITNESS CLASSES | | | | |

SWCC SWEETWATER CRK BPEREGRINO

| CHECK DATE | VEND# |INVOICE..... DATE INVOICE | ...EXPENSED TO... YRMO DPT ACCT# SUB SUBCLASS | VENDOR NAME | STATUS | AMOUNT |CHECK..... AMOUNT # |
|--------------------|-------|-----------------------------------|---|--------------------------------|--------|-----------|----------------------------|
| 10/24/24 | 00138 | 10/02/24 10022024 | 202409 340-53800-34500 9/17-9/24 FITNESS CLASSES | RONALD C. CULLUM | * | 105.00 | 105.00 002764 |
| 10/24/24 | 00023 | 9/06/24 90348514 | 202409 330-53800-52200 SHOWER N GO 1000ML | STATE CHEMICAL SOLUTIONS | * | 209.89 | 209.89 002765 |
| 10/24/24 | 00023 | 7/12/24 90341717 | 202407 330-53800-52200 SHOWER N GO 1000ML | STATE CHEMICAL SOLUTIONS | * | 209.89 | 209.89 002766 |
| 10/24/24 | 00136 | 10/17/24 10172024 | 202410 340-53800-34500 10/6-10/19 FITNESS CLASS | TIFFANY ROSE CUNNIGHAM | * | 105.00 | 105.00 002767 |
| 10/24/24 | 00136 | 9/19/24 09192024 | 202409 340-53800-34500 9/19 FITNESS CLASS | TIFFANY ROSE CUNNIGHAM | * | 35.00 | 35.00 002768 |
| 10/24/24 | 00136 | 10/03/24 10032024 | 202409 340-53800-34500 9/22-10/5 FITNESS CLASSES | TIFFANY ROSE CUNNIGHAM | * | 140.00 | 140.00 002769 |
| 10/24/24 | 00147 | 7/10/24 183 | 202410 330-53800-47800 REFINISH FLOORS DEPOSIT | PAUL STRATTON DBA 210 HANDYMAN | * | 2,600.00 | 2,600.00 002770 |
| TOTAL FOR BANK B | | | | | | 22,014.41 | |
| TOTAL FOR REGISTER | | | | | | 22,014.41 | |

Sweetwater Creek CDD
1865 North Loop Pkwy,
Saint Augustine, FL 32095

Amy Sue Long

84 Rio Del Norte Rd, St. Augustine, FL 32095

2023 Classes Taught in TWO week period:

Yoga 9/4 9/11
9/6 9/13

Substitute Dates:

Code: 2-340-53800-34500

Cost:

~~100~~ 140

RECEIVED
SEP 18 2024
BY: _____

Approved:

Amy Sue Long

ASL

Date:

9/13/24

9/13/24

Sweetwater Creek CDD
1865 North Loop Pkwy,
Saint Augustine, FL, 32095

Vendor: Diane Stoeber

153 Oak Common Ave. St. Augustine, FL 32095

2023 Classes Taught in TWO week period:

Sept 9 - 22

Pilates Dates:

Kids Fitness Dates: 9/11, 9/18

Stretch Dates: 9/9, 9/13, 9/20

Barre Dates: 9/9

Substitute Dates: Hit 9/12

Code: 2-340-53800-34500

Cost: 280.00

RECEIVED
SEP 18 2024
BY: _____

Approved:

[Signature]

Date:

9/28/24

Sweetwater Creek CDD
1865 North Loop Pkwy,
Saint Augustine, Fl, 32095

Vendor: Eliana Roque
138 Pickett Dr, St. Augustine, Fl 32084

2023 Classes Taught in TWO week period:

Cardio Core Dates: 9/10

Senior Mat Pilates Dates: 9/10

Senior Strength Dates: 9/11

Substitute Dates: 9/12

Code: 2-340-53800-34500

Cost: \$ ~~200.00~~ 160

RECEIVED
SEP 24 2024
BY: _____

Approved: *E. Roque*

Date: 9/18/24

Sweetwater Creek CDD
1865 North Loop Pkwy,
Saint Augustine, FL 32095

Vendor: Laura Correa

197 Paradas Pl, St. Augustine, FL 32092

2023 Classes Taught in TWO week period:

Zumba Dates: 09/5 & 09/12 - 6:00PM

Zumba Tone/Zumba Dates: 09/7 & 09/14 - 9:00AM

Substitute Dates:

Code: 2-340-53800-34500

Cost: \$140

RECEIVED
SEP 18 2024
BY: _____

Approved: *Laura Correa*

Date: 09/14/24

Sweetwater Creek CDD
1865 North Loop Pkwy,
Saint Augustine, FL, 32095

Vendor: Lina Hermez

248 Glorietta Dr, St. Augustine, FL 32095

2023 Classes Taught in TWO week period:

Meditation Dates: 7th, 11th Sep

Yogalates Dates: 3rd, 10th Sep

Power Pump Dates: 3rd, 10th Sep

Yoga Dates: 8th, 9th, 11th, 15th

Pilates Dates: 2nd, 9th

(2nd ~ 15th) Sep

RECEIVED
SEP 18 2024

Code: 2-340-53800-34500

Cost: \$450⁰⁰ dish

BY: _____

Approved:

E. Wj

Date: 15th, Sep 2024

Invoice

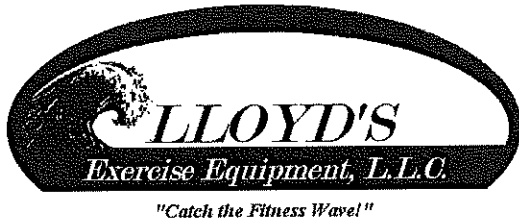

LLOYD'S Exercise Equipment, L.L.C
PO Box 290723
Port Orange, FL 32129
386-322-3213 (office)
815-331-5329 (fax)

| Purchase Date | Invoice # |
|---------------|-----------|
| 8/7/2024 | T480-97 |

Customer Bill To:
Sweetwater Creek CDD
District Accountant
1408 Hamlin Avenue, Unit E
Saint Cloud, FL 34771
904-239-5309 (Bernadette Peregrino)

| Invoice Date | Terms |
|--------------|----------------|
| 8/26/2024 | Due on receipt |

| Manufacturer | Item | Model | Details | Amount |
|--------------|---------------|---|------------|----------|
| Zoom | Fitness Wipes | <p>* Physical Address Sweetwater CDD 1865 North Loop Parkway St. Augustine, FL 32095 904-829-8488 (Erin Gunia)</p> <p>Disinfectant Fitness Wipes; 4 rolls per case; 800 wipes per roll; at \$130.00 per case.</p> | (10 cases) | 1,300.00 |

RECEIVED
SEP 25 2024
BY: _____

Thank you for your business.

| | |
|--------------------|-------------------|
| Subtotal | \$1,300.00 |
| Sales Tax (0.0%) | \$0.00 |
| Total | \$1,300.00 |
| Payments/Credits | \$0.00 |
| Balance Due | \$1,300.00 |

"Specializing in Service After the Sale"

Invoice

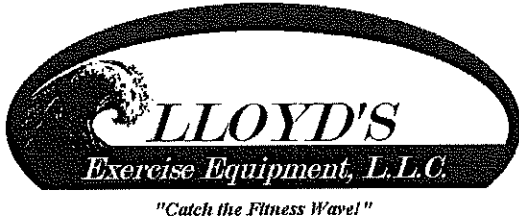

| | |
|----------------------|------------------|
| Purchase Date | Invoice # |
| 6/19/2024 | T480-96 |

| | |
|---|--|
| Customer Bill To: | |
| Sweetwater Creek CDD District Accountant 1408 Hamlin Avenue, Unit E Saint Cloud, FL 34771 904-239-5309 (Bernadette Peregrino) | |

LLOYD's Exercise Equipment, L.L.C
PO Box 290723
Port Orange, FL 32129
386-322-3213 (office)
815-331-5329 (fax)

| | |
|---------------------|----------------|
| Invoice Date | Terms |
| 6/20/2024 | Due on receipt |

| Manufacturer | Item | Model | Details | Amount |
|--------------|---------------|---|---|----------|
| Zoom | Fitness Wipes | * Physical Address Sweetwater CDD 1865 North Loop Parkway St. Augustine, FL 32095 904-829-8488 (Erin Gunia) | Disinfectant Fitness Wipes; 4 rolls per case; 800 wipes per roll; at \$130.00 per case. (8 cases) | 1,040.00 |

RECEIVED
 SEP 25 2024
 BY: _____

Thank you for your business.

| | |
|-------------------------|-------------------|
| Subtotal | \$1,040.00 |
| Sales Tax (0.0%) | \$0.00 |
| Total | \$1,040.00 |
| Payments/Credits | \$0.00 |
| Balance Due | \$1,040.00 |

"Specializing in Service After the Sale"

Sweetwater Creek CDD
1865 North Loop Pkwy,
Saint Augustine, FL 32095

Vendor: Miranda Bulger

2112 Pons Springs Way, Fleming Island, FL 32003

2023 Classes Taught in TWO week period:

Spin Dates: 9/9 9/11 9/16 9/18

HIIT Dates: 9/11 9/18

Substitute Dates:

Code: 2-340-53800-34500

Cost:

\$1245-

RECEIVED
SEP 24 2024
BY: _____

Approved:

Miranda Bulger
MB

Date:

9/18/24

Sweetwater Creek CDD
1865 North Loop Pkwy,
Saint Augustine, FL, 32095

Vendor: Patty Scott

256 Front Door Lane, St. Augustine, FL 32095

2023 Classes Taught in TWO week period:

Meditation Dates:

Spin 9/9 10:15 - 11:00 AM

Yogalates Dates:

Spin 9/16 10:15 - 11:00

Power Pump Dates:

Yoga Dates:

Pilates Dates:

Code: 2-340-53800-34500

Cost:

70⁰⁰

RECEIVED
SEP 18 2024
BY: _____

Approved:

WJ

Date:

9/18/24

Patty Scott



Invoice

Date
Invoice#

10/1/2024
131295624960

1707 Townhurst Dr.
Houston TX 77043
(800) 858-POOL (7665)
www.poolsure.com

| | |
|----------|------------|
| Terms | Net 30 |
| Due Date | 10/31/2024 |
| PO # | |

| Bill To |
|--|
| Attn: Berenadette Pegrino Sweetwater Creek CDD c/o GMS 475 West Town Place STE 114 Saint Augustine FL 32092 |

| Ship To |
|--|
| Sweetwater Creek CDD 1879 N Loop Pkwy Saint Augustine FL 32095 |

| Item | Description | Qty | Units | Amount |
|----------------------------------|------------------------------------|-----|-------|------------|
| WM-CHEM-FLAT | Water Management Flat Billing Rate | 1 | ea | \$2,054.80 |
| WM-XPC Upgrade | XPC System Upgrade | 1 | ea | \$0.00 |
| WM-Wireless Communication Charge | XPC Communication Fee | 1 | ea | \$0.00 |

Subtotal \$2,054.80

Tax \$0.00

Total \$2,054.80

Amount Paid/Credit Applied \$0.00

Balance Due \$2,054.80

RECEIVED
SEP 23 2024
BY: _____



131295624960

Poolsure Standard Terms & Conditions

1. These Standard Terms & Conditions govern the relationship between Poolsure and the other party (the "Customer") to the Estimate, Work Order, or similar document ("Work Authorization") to which these Standard Terms & Conditions are attached. As herein, (i) the term "Equipment" means any and all controllers, tanks, or other equipment sold, leased, or otherwise provided to Customer by Poolsure, if any; (ii) the term "Chemicals" means any and all chemicals provided by Poolsure to the Customer to maintain the chlorine, pH, alkalinity levels, calcium and cyanuric acid levels, and other water chemistry of Customer's swimming pools and other bodies of water (collectively, "Pools"), if any; and (iii) the term "Services" means any and all services furnished by Poolsure to Customer, including but not limited to maintenance and repair services, if any. The specific Equipment, Chemicals, and Services, and the terms upon which Poolsure agrees to provide the same to Customer are included on the Work Authorization. The provision of Equipment, Chemicals, and/or Services by Poolsure to Customer is referred to herein as the "Work". Poolsure agrees to perform the Work as described in the Work Authorization, and Customer agrees to provide Poolsure reasonable access to the area(s) where Work is to be performed.

2. **Leased Equipment.** All leased Equipment (and any replacement thereof), shall remain the sole property of Poolsure, and shall be returned to Poolsure at the end of the lease term in good working condition, reasonable wear and tear excepted. If the leased Equipment is not returned within 60 days of the expiration of the lease term, then Customer agrees to pay Poolsure an amount equal to the then current purchase price of each piece of the leased Equipment that has yet to be returned. In addition, Customer will still be responsible for returning the leased Equipment to Poolsure. All leased Equipment shall remain personal property (even though said Equipment may hereafter become attached or affixed to real property) and the title thereto shall at all times remain exclusively in Poolsure. At Customer's sole cost and expense, Customer shall (a) protect and defend Poolsure's ownership of and title to the leased Equipment from and against all persons claiming against or through Customer, (b) at all times keep the leased Equipment free from any and all liens, encumbrances, attachments, levies, executions, burdens, charges or legal processes imposed against Customer, (c) give Poolsure immediate written notice of any matter described in this sentence, and (d) cooperate with Poolsure to promptly remove any encumbrance described in this sentence. Customer shall keep the leased Equipment at the approved delivery and storage location and shall not remove them or allow any of the leased Equipment to be removed without Poolsure's prior, written consent, unless otherwise noted on the Work Authorization.

3. **Water Chemistry and Maintenance of Equipment.** Maintaining proper water chemistry in the Pools is the sole responsibility of Customer, despite Poolsure having agreed to provide the Chemicals and/or Equipment as a tool to assist Customer in connection therewith, as applicable. Customer agrees that it shall independently test the water chemistry of each Pool no less than daily (or more often if required by law), and shall keep an accurate and up-to-date written log of such tests as required by any applicable law. In the event that such tests reveal that any piece of Equipment is not maintaining proper water chemistry, Customer shall promptly notify Poolsure of the same, and Customer will add Chemicals to the Pools by hand or otherwise as necessary to maintain proper water chemistry therein, until such Equipment is repaired or replaced. Poolsure's sole responsibility hereunder is to supply Chemicals, sell and/or lease the Equipment, and/or to repair such Equipment as expressly requested by Customer and agreed to by Poolsure; all responsibility for maintenance of the Chemicals in the Pools shall accrue to and be the responsibility of the Customer. Customer acknowledges that it is Customer's responsibility to obtain and pay for all necessary permits and licenses needed to operate the Pools, and/or utilize the Equipment or Chemicals as required by applicable law. Any leased Equipment and feed system may only be used to feed approved chemicals provided by Poolsure. Customer shall not, under any circumstance, place or allow others to place products or chemicals obtained from any third-party in any piece of leased Equipment. Customer shall be solely responsible for any and all leaks in any piece of Equipment, and any circumstance arising or resulting from any leaks. Customer acknowledges that corrosion may result from Chemicals and Poolsure is not responsible for the same. It is recommended that a ventilation fan be installed in any enclosed Equipment/Chemical area to provide proper ventilation and minimize corrosion, and Customer shall install the same as required by applicable law. In the event the leased Equipment is damaged, including but not limited to as a result of the misuse, improper use, or other intentional and wrongful or negligent acts or omissions of Customer's officers, employees, agents, contractors (other than Poolsure) or invitees, to the extent such damage is not covered by any warranties or insurance, Poolsure may service or repair the Equipment as needed and the cost thereof shall be paid by Customer to Poolsure immediately upon written request, together with interest thereon at the rate of one and one-half percent (1.50%) per month (or the maximum monthly interest rate permitted to be charged by law, if less) and reasonable attorneys' fees and costs incurred by Poolsure in collecting such amount from Customer. Any work so performed by Poolsure shall not deprive Poolsure of any of its rights, remedies, or actions against Customer for such damage.

4. **Payment to Poolsure.** In consideration of the Work to be performed by Poolsure, Customer agrees to pay Poolsure, without reduction or set-off, the fees set forth in the Work Authorization. If payment in full is not received timely, then interest shall accrue on such unpaid amounts from the applicable due date until paid in full at the lesser of one and one-half percent (1.50%) per month and the maximum monthly interest rate permitted to be charged by law. Any pricing provided in the Work Authorization may be adjusted by Poolsure upon thirty (30) days prior written notice to Customer.

5. **Warranties by Poolsure.** All Services performed by Poolsure will be provided in a good and workmanlike manner; provided that Poolsure makes no warranty with respect to any 3rd party lab testing utilized by Poolsure. Customer's sole remedy with respect to the warranty provided on Services is the reperformance of the Services by Poolsure. Poolsure makes no warranty with respect to the Chemicals or Equipment, but Poolsure will assign or "pass-through" any manufacturer or 3rd party laboratory warranties to the extent the same may be assigned to Customer. POOLSURE SUPPLIES THE CHEMICALS AND EQUIPMENT UNDER THE WORK AUTHORIZATION IN THEIR "AS IS" CONDITION. EXCEPT AS SET FORTH IN THIS SECTION, POOLSURE MAKES NO WARRANTY OR REPRESENTATION, EITHER EXPRESSED OR IMPLIED, AS TO THE SERVICES, CHEMICALS OR EQUIPMENT, INCLUDING BUT NOT LIMITED TO ANY WARRANTY OR REPRESENTATION AS TO THE MERCHANTABILITY, FITNESS FOR A PARTICULAR PURPOSE OR USE, DESIGN, CONDITION, DURABILITY, CAPACITY, MATERIAL OR WORKMANSHIP OF THE CHEMICALS OR EQUIPMENT. POOLSURE SHALL NOT BE LIABLE FOR ANY DIRECT, INDIRECT OR CONSEQUENTIAL LOSSES OR DAMAGES SUFFERED BY CUSTOMER OR BY ANY OTHER PERSON FOR, AND CUSTOMER EXPRESSLY WAIVES ANY RIGHT TO HOLD POOLSURE LIABLE HEREUNDER FOR, ANY CLAIMS, DEMANDS AND LIABILITIES ARISING OUT OF OR IN CONNECTION WITH THE PERFORMANCE OF SERVICES OR THE DESIGN OR MANUFACTURE, POSSESSION OR OPERATION OF THE CHEMICALS OR EQUIPMENT, INCLUDING, WITHOUT LIMITATION, INJURY TO PERSONS OR PROPERTY RESULTING FROM THE FAILURE OF, DEFECTIVE OR FAULTY DESIGN, OPERATION, CONDITION, SUITABILITY OR USE OF THE CHEMICALS OR EQUIPMENT. Poolsure is not the manufacturer of the Equipment or Chemicals, or the manufacturer's agent.

6. **Indemnity and Limitation of Damages.** CUSTOMER HEREBY AGREES TO INDEMNIFY, DEFEND AND HOLD POOLSURE HARMLESS FROM AND AGAINST ALL CLAIMS, DAMAGES, ACTIONS, JUDGMENTS, SUITS, LOSSES, FINES, PENALTIES, DEMANDS, COSTS AND EXPENSES AND LIABILITY WHATSOEVER (AND ANY ATTORNEY'S FEES, WITNESS FEES, AND/OR COSTS INCURRED IN CONNECTION THEREWITH) (COLLECTIVELY THE "LOSSES") CAUSED BY OR ARISING FROM (A) CUSTOMER'S FAILURE TO FULLY PERFORM, OBSERVE OR SATISFY ITS COVENANTS, DUTIES, WARRANTIES AND OBLIGATIONS CONTAINED IN THE WORK AUTHORIZATION OR THESE STANDARD TERMS & CONDITIONS; (B) THE NEGLIGENT OR WRONGFUL USE AND OPERATION OF THE CHEMICALS OR EQUIPMENT DURING THE TERM BY CUSTOMER, ITS AGENTS, OFFICERS, EMPLOYEES, CONTRACTORS, OR INVITEES; (C) CUSTOMER'S FAILURE TO MAINTAIN PROPER WATER CHEMISTRY IN EACH AND EVERY POOL; (D) THE ACTS OR OMISSIONS OF CUSTOMER, ITS AGENTS, OFFICERS, EMPLOYEES, CONTRACTORS, OR INVITEES, INCLUDING BUT NOT LIMITED TO CUSTOMER'S FAILURE TO MAINTAIN AND UTILIZE THE EQUIPMENT AND THE CHEMICALS IN ACCORDANCE WITH APPLICABLE LAW; AND (E) THE STORAGE OF THE CHEMICALS ON CUSTOMER'S PREMISES. IF SUCH LOSSES WERE ALSO CAUSED IN PART BY THE ACTS OR OMISSIONS OF POOLSURE, THEN CUSTOMER SHALL ONLY BE LIABLE TO THE EXTENT AND FOR SUCH PORTION THAT SUCH LOSSES WERE CAUSED BY, ARISE FROM OR RELATE, TO THE ACTS OR OMISSIONS OF CUSTOMER, ITS OFFICERS, AGENTS, MANAGERS, CONTRACTORS EMPLOYEES AND/OR INVITEES. IN NO EVENT SHALL POOLSURE BE LIABLE FOR INCIDENTAL, CONSEQUENTIAL (INCLUDING LOST PROFITS), SPECIAL, PUNITIVE OR EXEMPLARY DAMAGES IN CONNECTION WITH THE WORK AUTHORIZATION, THE CHEMICALS OR EQUIPMENT, EVEN IF NOTICE WAS GIVEN OF THE POSSIBILITY OF SUCH DAMAGES AND EVEN IF SUCH DAMAGES WERE REASONABLY FORESEEABLE.

NOTWITHSTANDING THE FOREGOING, THE CUSTOMER HEREBY ASSUMES ANY AND ALL RISK OF LOSS, DAMAGE OR COSTS, OR PROPERTY DAMAGE TO CUSTOMER'S WALKWAYS, CONCRETE, PARKING LOTS, OR OTHER FLOORING ("CUSTOMER'S FLOORING") THAT MAY BE INCURRED IN CONNECTION WITH THE CUSTOMARY AND REASONABLE ACTS AND/OR OMISSIONS OF POOLSURE IN DELIVERING CHEMICALS TO CUSTOMER'S PROPERTY OVER STAINED, PAINTED, DECORATIVE OR NON-DECORATIVE WALKWAYS, CONCRETE, PARKING LOTS OR ANY OTHER FLOORING AREAS LOCATED ON CUSTOMER'S PROPERTY DESIGNATED BY CUSTOMER AS AN ACCESS FOR PRODUCT DELIVERY. HOWEVER, THE ABOVE DOES NOT WAIVE OR RELEASE ANY CLAIMS AGAINST POOLSURE FOR GROSS NEGLIGENCE OR WILLFUL MISCONDUCT ON THE PART OF POOLSURE, ITS AGENTS, EMPLOYEES, CONTRACTORS, OR REPRESENTATIVES. CUSTOMER ACKNOWLEDGES THAT THIS PARAGRAPH IN ITS NATURE IS A WAIVER FOR DAMAGES TO CUSTOMER'S FLOORING ARISING FROM AND DUE TO POOLSURE'S CUSTOMARY AND REASONABLE ACTIVITY OF DELIVERING CORROSIVE CHEMICALS OVER CUSTOMER'S FLOORING AND HEREBY RELEASES POOLSURE FOR CLAIMS OR DAMAGES TO CUSTOMER'S FLOORING RESULTING FROM POOLSURE'S CUSTOMARY AND REASONABLE ACTS IN CONNECTION WITH THE DELIVERY OF CHEMICALS TO CUSTOMER'S PROPERTY AND ASSUMES ANY AND ALL RISK OF LOSS, DAMAGE OR COSTS, OR PROPERTY DAMAGE TO CUSTOMER'S FLOORING THAT MAY BE INCURRED BY CUSTOMER ARISING OUT OF OR IN CONNECTION WITH POOLSURE'S CUSTOMARY AND REASONABLE ACTS AND/OR OMISSIONS IN DELIVERING CHEMICALS OVER STAINED, PAINTED, DECORATIVE OR NON-DECORATIVE WALKWAYS, PARKING LOTS OR ANY OTHER FLOORING AREAS DESIGNATED BY CUSTOMER TO BE ACCESS POINTS FOR PRODUCT DELIVERY. CUSTOMER FULLY UNDERSTANDS THE TERMS SET FORTH IN THIS PARAGRAPH, AND CUSTOMER HEREBY WAIVES ITS RIGHTS FREELY AND VOLUNTARILY WITHOUT ANY INDUCEMENT, ASSURANCE, OR GUARANTEE BEING MADE TO CUSTOMER TO THE FULLEST EXTENT ALLOWED BY LAW.

To the extent there is any conflict between the terms of this Section and the terms of any other agreement entered into between Poolsure and Customer, the terms of this Section shall control.

7. **Customer Event of Default.** The occurrence of any of the following shall constitute an event of default by Customer (a "Customer Event of Default"): (a) Customer fails to timely pay any payment when due to Poolsure; (b) Customer attempts to remove, sell, transfer, encumber, assign, sublet or part with possession of any leased equipment or any items thereof, except as expressly permitted herein; (c) Customer fails to observe or perform any of its material covenants, duties or obligations arising hereunder and such failure continues for a period of fifteen (15) days after written notice thereof by Poolsure; (d) Customer ceases doing business as a going concern, makes an assignment for the benefit of creditors, admits in writing its inability to pay its debts as they become due, files a voluntary petition in bankruptcy, is adjudicated as bankrupt or insolvent, files a petition seeking for itself any reorganization, arrangement, composition, readjustment, liquidation, dissolution or similar arrangement under any present or future statute, law or regulation or files an answer admitting the material allegations of a petition filed against it in any such proceeding, consents to or acquiesces in the appointment of a trustee, receiver, or liquidator of it or of all or any substantial part of its assets or properties, or it or its shareholders or other equity owners shall take any action looking to its dissolution or liquidation.

8. **Remedies Upon Customer Event of Default.** Upon the occurrence of any Customer Event of Default, Poolsure may at its option do any or all of the following: (a) By written notice to Customer, immediately terminate the Work Authorization and the related provision of Services, Equipment, or Chemicals. As a result of the termination, Poolsure may enter upon Customer's property and remove any leased Equipment without liability of any kind or nature for so doing, or Poolsure may demand that Customer remove and return the leased Equipment, all at Customer's sole cost and expense; or (b) Exercise any other right or remedy which may be available to Poolsure under any applicable law or proceed by appropriate court action, without affecting Poolsure's title or right to possession of the leased Equipment, to enforce the terms hereof or to recover damages from the Customer Event of Default or to terminate the Work Authorization and the related provision of Services, Equipment, or Chemicals.

9. **Insurance.** Customer shall, at its cost and expense, purchase and maintain in effect general and professional liability insurance covering all losses and the use, operation, and replacement of the leased Equipment and/or Chemicals. Upon written request by Poolsure, Poolsure shall be named as an additional insured party on the insurance policies to be maintained hereunder by Customer, and Customer shall deliver a certificate of insurance or other reasonable documentation to Poolsure within ten (10) days of such request.

10. **Miscellaneous.** The Work Authorization and these Standard Terms & Conditions and all claims or causes of action arising hereunder shall be governed by and construed in accordance with the laws of the State of Texas, excluding its conflicts of laws provisions, and in the event of a dispute arising under or in connection with the Work Authorization or these Standard Terms & Conditions, the parties hereby submit to exclusive jurisdiction in the federal or state courts located in Harris County, Texas, and agree that venue is proper and convenient in such forum. Poolsure shall not be liable for default in the performance or discharge of any duty or obligation under the Work Authorization or these Standard Terms & Conditions, to the extent caused by acts of God, civil or military authority, public enemy, fire, floods, winds, storms, pandemic, epidemic, public health emergency or quarantine, labor disorders, strikes, work stoppages or other labor trouble, accidents, riots, civil commotion, closing the public highways, terrorist acts or threats, governmental interference or regulations and other contingencies, similar to the foregoing, beyond Poolsure's reasonable control. The failure of either party to enforce any of the rights given to it under the Work Authorization or these Standard Terms & Conditions shall not be construed as a waiver of the right of such party to exercise any such right as to any subsequent violations of the Work Authorization and these Standard Terms & Conditions. Except as specifically set forth herein, neither party shall assign the Work Authorization or its rights or obligations thereunder without the prior written consent of the other party. The Work Authorization and these Standard Terms & Conditions shall be binding upon and shall inure to the benefit of the parties hereto, and their respective successors and permitted assigns. The Work Authorization and these Standard Terms & Conditions constitute the entire agreement between the parties with respect to the matters set forth herein. Any change, addition, deletion or other modification to the Work Authorization and these Standard Terms & Conditions shall be null and void unless in writing and signed by both parties. All notices required to be provided in writing hereunder shall be sent to the party in question at its address set forth on the Work Authorization, by hand delivery or international delivery service, return receipt requested. In the event of any controversy, claim or dispute between the parties hereto, arising out of or relating to the Work Authorization or the breach thereof, the prevailing party shall be entitled to recover from the other party its reasonable expenses, attorney's fees, and costs. The provisions of these Standard Terms & Conditions which by their nature require some action or forbearance after termination of the Work Authorization or completion of the Work (including but not limited to those related to indemnities) shall survive and be binding until any actions, obligations and/or rights therein provided have been completely satisfied or released.

Sweetwater Creek CDD
1865 North Loop Pkwy,
Saint Augustine, FL, 32095

Ron Cullum
416 Heather Dr, St. Augustine, FL 32095

2023 Classes Taught in TWO week period:
2024
Sep 10TH & 12TH
Tai chi Tue & Thurs 12:30
1:30

Substitute Dates:

Code: 2-340-53800-34500

Cost: \$70.50

RECEIVED
SEP 18 2024
BY: _____

Approved: *[Signature]* Date: 9/18/24
12 Sep 2024



PAYMENT ADDRESS:
 Turner Pest Control LLC • P.O. Box 952503 • Atlanta, Georgia 31192-2503
 904-355-5380 • Fax: 804-353-1499 • Toll Free: 800-225-5395 • turnerpest.com

Service Slip/Invoice

INVOICE: 619416877
DATE: 08/12/2024
ORDER: 619416877

Bill To: [216013]
 Sweet Water Creek CDD
 C/O GMS
 475 W Town Pl Ste 114
 Saint Augustine, FL 32092-3649

Work Location: [216013] 904-940-5850
 Sweetwater Creek CDD
 1865 N Loop Pkwy
 Saint Augustine, FL 32095-6842

| Work Date | Time | Target Pest | Technician | Time In |
|------------|----------|-------------|------------|----------|
| 08/12/2024 | 03:37 PM | | | 03:37 PM |

| Purchase Order | Terms | Last Service | Map Code | Time Out |
|----------------|--------|--------------|----------|----------|
| | NET 30 | 09/19/2024 | | 04:12 PM |

| Service | Description | Price |
|---------|-------------|-------|
|---------|-------------|-------|

CPCM Commercial Pest Control - Monthly Service \$81.19

SUBTOTAL \$81.19
TAX \$0.00
AMT. PAID \$0.00
TOTAL \$81.19

AMOUNT DUE \$81.19

Pest Control
 2.340.53800.34400
 DW
 9/27/24

RECEIVED
 SEP 27 2024
 BY: _____

* Balances outstanding over 30 days from the date of service may be subject to a late fee of the lesser of 1.5% per month (18% per year) or the maximum allowed by law. Customer agrees to pay accrued expenses in the event of collection.

I hereby acknowledge the satisfactory completion of all services rendered, and agree to pay the cost of services as specified above.

PLEASE PAY FROM THIS INVOICE

20240812 03:37 PM 03:37 PM 04:12 PM 09/19/2024 08/12/2024 03:37 PM 04:12 PM 09/19/2024 08/12/2024 03:37 PM 04:12 PM 09/19/2024



PAYMENT ADDRESS:
 Turner Pest Control LLC • P.O. Box 952503 • Atlanta, Georgia 31192-2503
 904-355-5300 • Fax: 904-353-1489 • Toll Free: 800-225-5305 • turnerpest.com

Turner Pest Control LLC
 P.O. Box 952503
 Atlanta, GA 31192-2503
 904-355-5300

Service Slip/Invoice

INVOICE: 619543265
DATE: 09/19/2024
ORDER: 619543265

Bill To: [216013]
 Sweet Water Creek CDD
 C/O GMS
 475 W Town Pl Ste 114
 Saint Augustine, FL 32092-3649

Work Location: [216013] 904-940-5850
 Sweetwater Creek CDD
 1865 N Loop Pkwy
 Saint Augustine, FL 32095-6842

| Work Date | Time | Target Pest | Technician | Time In |
|------------|----------|-------------|------------|----------|
| 09/19/2024 | 11:05 AM | | | 11:05 AM |

| Purchase Order | Terms | Last Service | Map Code | Time Out |
|----------------|--------|--------------|----------|----------|
| | NET 30 | 09/19/2024 | | 12:05 PM |

| Service | Description | Price |
|---------|---|---------|
| CPCM | Commercial Pest Control - Monthly Service | \$81.19 |

| | |
|------------------|---------|
| SUBTOTAL | \$81.19 |
| TAX | \$0.00 |
| AMT. PAID | \$0.00 |
| TOTAL | \$81.19 |

Pest Control
 2.340.53800.34400
 DW
 9/20/24

AMOUNT DUE \$81.19

TECHNICIAN SIGNATURE

erin
 CUSTOMER SIGNATURE

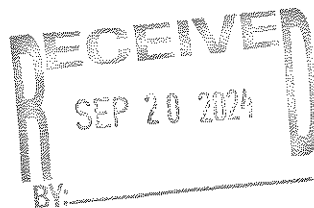

* Balances outstanding over 30 days from the date of service may be subject to a late fee of the lesser of 1.5% per month (18% per year) or the maximum allowed by law. Customer agrees to pay accrued expenses in the event of collection.

I hereby acknowledge the satisfactory completion of all services rendered, and agree to pay the cost of services as specified above.

| | | |
|----------------|------------|--------|
| INVOICE | Date | Number |
| | 10/01/2024 | 352506 |

Village Key & Alarm, Inc
441 State Road 16
St. Augustine, FL 32084
904-824-5003

| | |
|------------------|-----------|
| ACCOUNT # | SLD801374 |
|------------------|-----------|

PALENCIA SWIM & FITNESS
Care of Sweetwater Creek CDD
625 PALENCIA CLUB DR
SAINT AUGUSTINE, FL 32095

| |
|--|
| Service Address |
| SWEETWATER CREEK FITNESS CEN TER SWEETWATER CREEK CDD 1865 NORTH LOOP PARKWAY SAINT AUGUSTINE, FL 32095 |

| Quan | Item | Description | Price | Tax % | Amount |
|------|------|---|---------|-------|---------|
| 3 | 600 | RESIDENTIAL BURGLAR PHONE LINE MONITORING 10/01/2024 to 12/31/2024 | \$20.00 | | \$60.00 |

Approved
Security 2-330-53800-47800

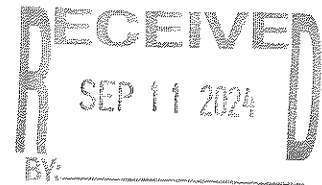

| | | | | | |
|----------------|----------------|----------------|----------------|----------------------|----------------|
| Current | 30 Days | 60 Days | 90 Days | SUB-TOTAL | \$60.00 |
| \$0.00 | \$0.00 | \$0.00 | \$0.00 | SALES TAX | \$0.00 |
| | | | | INVOICE TOTAL | \$60.00 |

| | | |
|---|------------------|----------------|
| Due to credit card processing merchant changes and restrictions, all VKA enabled auto payments were disabled as of 5/2/2024. We have updated the credit card processing method for customers to enroll in an automatic payment process. If you would like to enroll or make a payment call our office at 904-824-5003 Option 5. Thank you for your understanding. | TOTAL DUE | \$60.00 |
|---|------------------|----------------|

Detach Here

PALENCIA SWIM & FITNESS
Care of Sweetwater Creek CDD
625 PALENCIA CLUB DR
SAINT AUGUSTINE, FL 32095

VKA Security
Village Key & Alarm, Inc
441 State Road 16
St. Augustine, FL 32084

| | |
|--|------------------|
| Account Number | SLD801374 |
| Invoice Number | 352506 |
| Amount Due | \$60.00 |
| Amount Paid | |
| Reminder: To ensure reliable system operation test your alarm frequently and keep your emergency call list updated. Visit our website, <https://villagekeyalarm.com/> , for step-by-step instructions or e-mail us at <mailto:info@vkalarm.com.%0c%0cInvoice> | |

Please detach and return this portion with your payment.
Page 1

Sweetwater Creek CDD
1865 North Loop Pkwy,
Saint Augustine, FL, 32095

Amy Sue Long

84 Rio Del Norte Rd, St. Augustine, FL 32095

2023 Classes Taught in TWO week period:

Yoga 10/2 10/11
10/4

Substitute Dates:

Code: 2-340-53800-34500

Cost: ~~\$100~~ 105

RECEIVED
OCT 18 2024
BY: _____

Approved: *Amy Sue Long*

Date: 10/19/24

ELD

Sweetwater Creek CDD
1865 North Loop Pkwy,
Saint Augustine, FL, 32095

Amy Sue Long

84 Rio Del Norte Rd, St. Augustine, FL 32095

2023 Classes Taught in TWO week period:

Yoga 9/18 9/25
9/20 9/27

Substitute Dates:

Code: 2-340-53800-34500

Cost: \$~~100~~ 140

RECEIVED
OCT 04 2024
BY: _____

Approved:

Amy Sue Long
ASL

Date: 9/29/24

CHECK REQUEST FORM

Project: Sweetwater Creek C.D.D.

Vendor: Chairmans Enterprises

Check Amount: \$1026.40

Check Needed: ASAP
Cost Code: 2-330-53800-44000

Requestor: Erin Gunia

Description: Spin Bike Lease

RECEIVED
OCT 02 2024
BY: _____

Approved By: _Erin Gunia **Date:** _10/01/2024

Chairmans Enterprises

Invoice # 1233

11586 Tyndel Creek Lane
 Jacksonville, FL 32223
 (904) 536-7746
 SEPTEMBER 1st, 2024

RECEIVED
 OCT 02 2024
 BY: _____

Sweetwater Creek CDD
 1865 North Loop Parkway St.
 Augustine, FL 32095

| Qty | Description | Unit | Total |
|-----|---|----------|----------|
| 8 | For Lease of Lemond Pro Indoor Cycling Bikes | \$51.32 | \$410.56 |
| 1 | For Lease of Commercial Spirit Airbike AB900 | \$102.64 | \$102.64 |
| | 09/01/2024 through 09/31/2024 | | |
| | 2-330-53800-44000 - 513.20 - Equipment Lease Spin Bikes | | |
| | <i>R.L.M.</i> | | |
| | Terms: 30 Day Net | | |
| | | Subtotal | \$513.20 |

Chairmans Enterprises

Invoice # 1237

11586 Tyndel Creek Lane
Jacksonville, FL 32223
(904) 536-7746
OCTOBER 1st, 2024

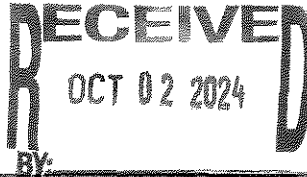

Sweetwater Creek CDD
1865 North Loop Parkway St.
Augustine, FL 32095

| Qty | Description | Unit | Total |
|-----|--|----------|----------|
| 8 | For Lease of Lemond Pro Indoor Cycling Bikes | \$51.32 | \$410.56 |
| 1 | For Lease of Commercial Spirit Airbike AB900 | \$102.64 | \$102.64 |
| | 10/01/2024 through 10/31/2024 | | |
| | Terms: 30 Day Net | | |
| | | Subtotal | \$513.20 |

Sweetwater Creek CDD
1865 North Loop Pkwy,
Saint Augustine, FL, 32095

Vendor: Diane Stoeber

153 Oak Common Ave. St. Augustine, FL 32095

2023 Classes Taught in TWO week period: Oct 7 - Oct 20

Pilates Dates:

Kids Fitness Dates:

Stretch Dates:

Barre Dates:

Substitute Dates:

10/9, 10/14

10/7, 10/11, 10/14, 10/13

10/7, 10/14

10/17 sub (Pilates^{Sr.})

Code: 2-340-53800-34500

Cost: \$300.00

RECEIVED
OCT 18 2024
BY: _____

Approved:



Date:

10/14/24

Sweetwater Creek CDD
1865 North Loop Pkwy,
Saint Augustine, FL 32095

Vendor: Diane Stoever

153 Oak Common Ave. St. Augustine, FL 32095

2023 Classes Taught in TWO week period: Sept 23 - Oct 6^m

Pilates Dates:

Kids Fitness Dates: 9/25, 10/2

Stretch Dates: 9/23, 9/27, 9/30, 10/4

Barre Dates: 9/23, 9/30

Substitute Dates:

Code: 2-340-53800-34500

Cost: \$ 320.00

RECEIVED
OCT 04 2024
BY: _____

Approved: *[Signature]*

Date: 10/3/24



Duval Landscape Maintenance
 7011 Business Park Blvd N
 Jacksonville, FL 32256
 www.duvallandscape.com

INVOICE

| Date | Invoice No. |
|----------|-------------|
| 10/01/24 | 28700 |
| Terms | Due Date |
| Net 40 | 11/10/24 |

| BILL TO |
|---|
| Sweetwater Community Development District 475 West Town Place, Suite 114 |

| PROPERTY |
|--|
| Sweetwater Creek CDD 605 Palencia Club Dr |

| Amount Due | PO Number |
|------------|-----------|
| \$1,963.00 | |

Please detach top portion and return with your payment.

| DESCRIPTION | UOM | QTY | UNIT PRICE | EXT PRICE | TOTAL |
|--|-----|-----|------------|-----------|------------|
| #31603 - Sweetwater Fitness Center and Dog | | | | | \$1,963.00 |

Monthly Break Down

- Monthly Maintenance -Mowing, edging, blowing, trimming /detail \$1,459.59
- Fertilization- \$130.66
- Bedding Plants (ANNUALS) - \$373.00

| | |
|--------------------|-------------------|
| Total | \$1,963.00 |
| Payments/Credits | (\$0.00) |
| Balance Due | \$1,963.00 |

Landscape maint and material
 2.330.53800.46200
 10/2/24
 DW

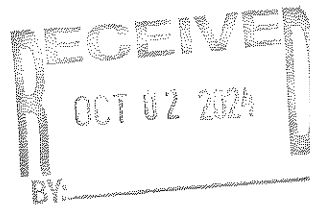

Sweetwater Creek CDD
1865 North Loop Pkwy,
Saint Augustine, FL 32095

Vendor: Eliana Roque

138 Pickett Dr, St. Augustine, FL 32084

2023 Classes Taught in TWO week period:

Cardio Core Dates: 10/12 - 10/18 10/15

Senior Mat Pilates Dates: 10/12 - 10/18 10/15

Senior Strength Dates: 10/22 - 10/29 10/14

Substitute Dates: 10/31 Pilates

Code: 2-340-53800-34500

Cost: \$ 400.00

RECEIVED
OCT 18 2024
BY: _____

Approved:

Eliana Roque

Date: 10/3/24

CRV

Sweetwater Creek CDD
1865 North Loop Pkwy,
Saint Augustine, FL 32095

Vendor: Eliana Roque
138 Pickett Dr, St. Augustine, FL 32084

2023 Classes Taught in TWO week period:

Cardio Core Dates: 9/17 - 9/24

Senior Mat Pilates Dates: 9/17 - 9/24

Senior Strength Dates: 9/18 - 9/25

Substitute Dates: 9/19 - 9/16 - 9/26

RECEIVED
OCT 04 2024
BY: _____

Code: 2-340-53800-34500

Cost: $\$200^{\circ}$
 $\$160$
 $\$360$

$\$360^{\circ}$

Approved: 

Date: 9/28/24

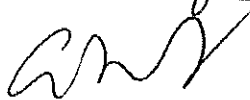

Envera

8281 Blaikie Court
Sarasota, FL 34240
(941) 556-7066

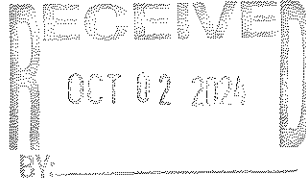

| Invoice | |
|----------------------------------|-------------------------------|
| Invoice Number 746544 | Date 10/01/2024 |
| Customer Number 300299 | Due Date 11/01/2024 |

Page: 1

| Customer Name | Customer Number | PO Number | Invoice Date | Due Date |
|----------------------|-----------------|-----------|--------------|------------|
| Sweetwater Creek CDD | 300299 | | 10/01/2024 | 11/01/2024 |

| Quantity | Description | Months | Rate | Amount |
|---|--|--------|------------|------------------|
| <i>2898 - Gate Access - Sweetwater Creek CDD - Entrance 1 (North Loop Parkway, Entrance2 (South Loop Parkway, Saint Augustine, FL</i> | | | | |
| 1.00 | Envera Kiosk System 11/01/2024 - 11/30/2024 | 1.00 | \$500.00 | \$500.00 |
| 1.00 | Service & Maintenance 11/01/2024 - 11/30/2024 | 1.00 | \$464.80 | \$464.80 |
| 1.00 | Data Management 11/01/2024 - 11/30/2024 | 1.00 | \$250.00 | \$250.00 |
| 1.00 | Virtual Gate Guard Monitoring 11/01/2024 - 11/30/2024 | 1.00 | \$2,213.25 | \$2,213.25 |
| Subtotal: | | | | \$3428.05 |
| Tax | | | | \$0.00 |
| Payments/Credits Applied | | | | \$0.00 |
| Invoice Balance Due: | | | | \$3428.05 |

| Date | Invoice # | Description | Amount | Balance Due |
|-----------|-----------|---------------------|-----------|-------------|
| 10/1/2024 | 746544 | Monitoring Services | \$3428.05 | \$3428.05 |

Envera

8281 Blaikie Court
Sarasota, FL 34240
(941) 556-7066

Security
2.330.53800.48400
10/2/24
DW

| Invoice | |
|----------------------------------|-------------------------------|
| Invoice Number 746544 | Date 10/01/2024 |
| Customer Number 300299 | Due Date 11/01/2024 |

Net Due: \$3,428.05

Amount Enclosed: _____

Sweetwater Creek CDD
C/O GMS
475 West Town Place Ste 114
Saint Augustine, FL 32092



Envera
PO Box 2086
Hicksville, NY 11802

Sweetwater Creek CDD
1865 North Loop Pkwy,
Saint Augustine, Fl, 32095

Vendor: Heather Rebella

336 Vale Dr, St. Augustine, Fl 32095

2023 Classes Taught in TWO week period:

2024

9/10/24 - 8:30-9:30

9/17/24 - 8:30-9:30

Substitute Dates:

Sub for Tiffany C. classes

Code: 2-340-53800-34500

Cost:

70⁰⁰

RECEIVED
OCT 04 2024
BY: _____

Approved:

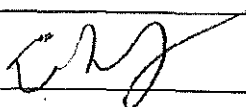

Date:

10/2/24

CHECK REQUEST FORM

Project: Sweetwater Creek C.D.D.
Vendor: Integrated Access Solutions LLC,
227 Crystal Cove Dr, Green Cove Springs, Fl, 32043-9604

Check Amount: \$150.00

Check Needed: ASAP
Cost Code: 2-330-53800-48100

Requestor: Erin Gunia

Description: Pickleball Gate repair

RECEIVED
OCT 18 2024
BY: _____

Approved By: Erin Gunia Date: 10/16/2024

Integrated Access Solutions, LLC

2227 Crystal Cove Dr.
Green Cove Springs, FL
32043-9604 USA chris@iasnfl.com

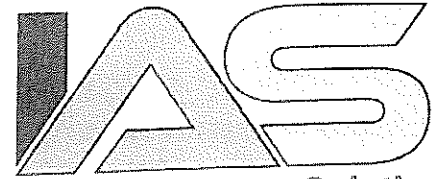

Integrated Access Solutions
INTEGRATION THAT WORKS FOR YOU

INVOICE

BILL TO

Sweetwater Creek
CDD 1865 N. Loop
PKWY.
St. Augustine Fl.
32095

INVOICE 1625
DATE 04/04/2024
TERMS Due on receipt
DUE DATE 04/04/2024

| DATE | SERVICE | DESCRIPTION | QTY | RATE | AMOUNT |
|------------|-------------------|---|-----|--------|--------|
| 04/03/2024 | Technicians Notes | Service call response for gate maglock at pickle ball court falling off post. | 1 | 0.00 | 0.00 |
| 04/03/2024 | Labor | Gate lock for the pickle ball court by the big gym had loose bolts. Put some lock tight and tighten down really good. Job is complete. Labor for installation, setup, and testing. | 1 | 150.00 | 150.00 |

Contact Integrated Access Solutions, LLC to pay Payment Due upon Receipt of Invoice

| | |
|----------|--------|
| SUBTOTAL | 150.00 |
| TAX | 0.00 |
| TOTAL | 150.00 |

Sweetwater Creek CDD
1865 North Loop Pkwy,
Saint Augustine, FL 32095

Vendor: Josie Lynn Carleton
181 Medio Dr, St. Augustine, FL 32095

2023 Classes Taught in TWO week period:

Substitute Dates: Mon - 9/16/24 - Bone SUB @ 6AM

Code: 2-340-53800-34500

Cost: 3500

RECEIVED
OCT 04 2024
BY: _____

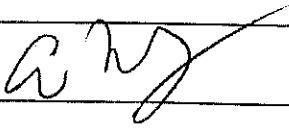
Approved: 

Date: 10/2/24

Sweetwater Creek CDD
1865 North Loop Pkwy,
Saint Augustine, FL 32095

Vendor: Laura Correa

197 Paradas Pl, St. Augustine, FL 32092

2023 Classes Taught in TWO week period:

Zumba Dates:

09/19 - 6:00PM

Zumba Tone/Zumba Dates:

09/21 & 09/28 - 9:00AM

Substitute Dates:

Code: 2-340-53800-34500

Cost:

\$105

RECEIVED
OCT 04 2024
BY: _____

Approved:

[Signature]
[Signature]

Date: 09/28/24

Sweetwater Creek CDD
1865 North Loop Pkwy,
Saint Augustine, FL 32095

Vendor: Lina Hermez
248 Glorietta Dr, St. Augustine, FL 32095

2023 Classes Taught in TWO week period: 16th ~ 29th sep
Meditation Dates: 18th, 25th sep
Yogalates Dates: 17th, 24th sep
Power Pump Dates: 17th, 24th sep
Yoga Dates: 18th, 22nd, 25th, 29th sep
Pilates Dates: 16th, 23rd sep

Code: 2-340-53800-34500
Cost: \$450⁰⁰ *alpha*
RECEIVED
OCT 18 2024
BY: _____

Approved: *ENJ* Date: 29th Sep 2024

CHECK REQUEST FORM

Project: Sweetwater Creek C.D.D.

Vendor: Lloyd's Exercise Equipment

Check Amount: \$2860.00

Check Needed: ASAP
Cost Code: 2-330-53800-52100

Requestor: Erin Gunia

Description: Gym Wipes

RECEIVED
OCT 02 2024
BY: _____

Approved By: __Erin Gunia **Date:** _10/01/2024

| | |
|----------------------|-----------|
| Purchase Date | Invoice # |
| 8/30/2024 | T480-98 |
| Customer Bill To: | |

Sweetwater Creek CDD
District Accountant
1408 Hamlin Avenue, Unit E
Saint Cloud, FL 34771
904-239-5309 (Bernadette Peregrino)

LLOYD's Exercise Equipment, L.L.C
PO Box 290723
Port Orange, FL 32129
386-322-3213 (office)
815-331-5329 (fax)

| | |
|--------------|----------------|
| Invoice Date | Terms |
| 9/30/2024 | Due on receipt |

| Manufacturer | Item | Model | Details | Amount |
|--------------|---------------|---|------------|----------|
| Zoom | Fitness Wipes | * Physical Address Sweetwater CDD 1865 North Loop Parkway St. Augustine, FL 32095 904-829-8488 (Erin Gunia) Disinfectant Fitness Wipes; 4 rolls per case; 800 wipes per roll; at \$130.00 per case. RECEIVED OCT 02 2024 BY: _____ | (10 cases) | 1,300.00 |

Subtotal \$1,300.00

LLOYD's Exercise Equipment, L.L.C
 PO Box 290723
 Port Orange, FL 32129
 386-322-3213 (office)
 815-331-5329 (fax)

| | |
|---------------|-----------|
| Purchase Date | Invoice # |
| 9/30/2024 | T480-99 |

Customer Bill To:
 Sweetwater Creek CDD
 District Accountant
 1408 Hamlin Avenue, Unit E
 Saint Cloud, FL 34771
 904-239-5309 (Bernadette Peregrino)

| | |
|--------------|----------------|
| Invoice Date | Terms |
| 9/30/2024 | Due on receipt |

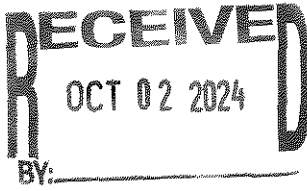
| Manufacturer | Item | Model | Details | Amount |
|--------------|---------------|---|------------|----------|
| Zoom | Fitness Wipes | * Physical Address Sweetwater CDD 1865 North Loop Parkway St. Augustine, FL 32095 904-829-8488 (Erin Gunia) | (12 cases) | 1,560.00 |
| | | Disinfectant Fitness Wipes; 4 rolls per case; 800 wipes per roll; at \$130.00 per case. | | |
| | | <div style="text-align: center;">  </div> | | |

Subtotal \$1,560.00

Sweetwater Creek CDD
1865 North Loop Pkwy,
Saint Augustine, FL 32095

Vendor: Miranda Bulger

2112 Pons Springs Way, Fleming Island, FL 32003

10/7 - 10/16

2023 Classes Taught in TWO week period:

Spin Dates: 10/7 10/9 10/1

HIIT Dates: 10/9 10/14, 10/16 (90 min)

Substitute Dates:

Code: 2-340-53800-34500

Cost: \$175.00

RECEIVED
OCT 18 2024
BY: _____

Approved: _____

Date: 10/15/24

Sweetwater Creek CDD
1865 North Loop Pkwy,
Saint Augustine, Fl, 32095

Vendor: Miranda Bulger
2112 Pons Springs Way, Fleming Island, ,Fl 32003

2023 Classes Taught in TWO week period:

Spin Dates: 9/23 9/25 9/30 10/2



HIIT Dates: 9/25 10/2

Substitute Dates:

Code: 2-340-53800-34500

Cost: \$1245⁰⁰

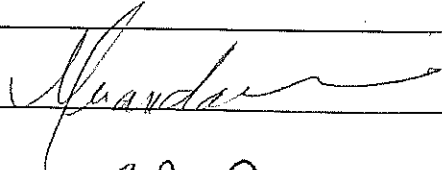
RECEIVED
OCT 04 2024
BY: _____

Approved: 

Date: 10/2/24

Sweetwater Creek CDD
1865 North Loop Pkwy,
Saint Augustine, FL 32095

Vendor: Patty Scott
256 Front Door Lane, St. Augustine, FL 32095

2023 Classes Taught in TWO week period:

Meditation Dates:

Spin 10/7 10-10:45

Yogalates Dates:

Spin 10/14 10-10:45

Power Pump Dates:

Yoga Dates:

Pilates Dates:

Code: 2-340-53800-34500

Cost:

70⁰⁰

RECEIVED
OCT 18 2024
BY: _____

Approved:

[Signature]

Date:

10/15/24

Sweetwater Creek CDD
1865 North Loop Pkwy,
Saint Augustine, FL, 32095

Vendor: Patty Scott

256 Front Door Lane, St. Augustine, FL 32095

2023 Classes Taught in TWO week period:

Meditation Dates:

9/23 Spin 10:15 - 11:00

Yogalates Dates:

9/30 Spin 10:15 - 11:00

Power Pump Dates:

Yoga Dates:

Pilates Dates:

Code: 2-340-53800-34500

Cost:

70⁰⁰

RECEIVED
OCT 04 2024
BY: _____

Approved:



Date:

10/2/24



Sweetwater Creek CDD
1865 North Loop Pkwy,
Saint Augustine, FL 32095

Vendor: Ron Collum
416 Heather Dr St. Augustine, FL 32095

²⁴
2025 Classes Taught in TWO week period:
Tai Chi Tues + Thurs
1230-130
Tai Chi Dates: 1 OCT, 3 OCT, 8 OCT
Substitute Dates: ~~10 OCT~~

 $3 \times 35 = 105$

Code: 2-340-53800-34500

Cost: \$105

RECEIVED
OCT 18 2024
BY: _____

Approved: *[Signature]*
Date: 10/15/24

Sweetwater Creek CDD
1865 North Loop Pkwy,
Saint Augustine, Fl, 32095

Vendor: Ron Collum

416 Heather Dr St. Augustine, Fl 32095

2023 Classes Taught in TWO week period:

2/

Tues + Thurs 1230-150

Tai Chi Dates:

Sept 17, 19, 24, ~~26~~

Substitute Dates:

$3 \times 35 = 105$

Code: 2-340-53800-34500

Cost:

105

RECEIVED
OCT 04 2024

BY: _____

Approved:

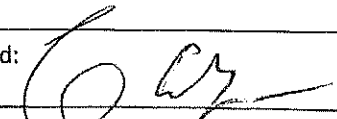
10/11

Date:

10/2/24



State Chemical Solutions
 6915 Landerbrook Drive Suite 300
 Mayfield Heights, Ohio 44124
 www.statechemical.com
 Phone: 440-565-5555 Fax: 1-888-771-9670
 A Division Of State Industrial Products Corp.

Invoice

| Document No. | Document Date | Due Date |
|--------------|---------------|------------|
| 903485147 | 09/06/2024 | 10/06/2024 |

We have no Fax number on file.
 Our Customer Service Phone number is: 1-800-782-2436

BILL TO:
 Customer No.: 706920

SWEET WATER FITNESS CENTER
C/O MARSHALL CREEK CDD
1865 N LOOP PKWY
SAINT AUGUSTINE, FL 32095-6842
USA

SHIP TO:

SWEET WATER FITNESS CENTER
C/O MARSHALL CREEK CDD
1865 N LOOP PKWY
SAINT AUGUSTINE, FL
32095-6842



001010 Safety Data Sheets are available at <http://statechemical.com/safety-data-sheets>

| Customer PO: Erin | | Sales Order: 501899498 | | Delivery: 804860678 | | | |
|--|---------|------------------------|------------|---------------------|------------------------|------------|----------------|
| Account Manager: 90148472 JEFFREY ATWOOD | | | Taxable: N | | | | |
| Open Qty | Ord Qty | Ship Qty | U M | Item | Description | Unit Price | Extended Price |
| 0 | 1 | 1 | CS | 128036 | SHOWER N GO 1000ML CS6 | 209.890 | 209.89 |

RECEIVED
 OCT 02 2024
 BY: _____

- IMPORTANT: Please return remittance portion below with your payment.
 - All tax exempt customers must submit a tax exempt certificate with payment.
 - Claims for shortage or damaged goods must be made within 5 days after receipt of goods.
 - No returns without a Return Goods Authorization.
 - Contact Customer Service concerning invoices, damaged product, or returns at 1-800-782-2436.
- Our Federal Tax ID: 34-0552740

| Net Sales | Shipping&Processing | Sales Tax | TOTAL |
|-----------|---------------------|-----------|--------|
| 209.89 | 0.00 | 0.00 | 209.89 |

PAY NO MONEY TO ACCOUNT MANAGER

FOR CHEMICAL EMERGENCY SPILL,
 LEAK, FIRE, EXPOSURE OR ACCIDENT
 CALL CHEMTREC 24/7 AT (800)
 424-9300.

PLEASE DETACH AND RETURN WITH PAYMENT

Please update your remittance information as shown below.

Make Checks Payable to:
State Industrial Products

REMITTANCE INFORMATION
 P.O. BOX 830316
 Philadelphia, PA
 19182-0316

| Invoice No | Due Date | Customer No | Acct Mgr | Total Due |
|--------------------------|-----------------------|--------------------------|------------|--------------------------|
| 903485147 | 10/06/2024 | 706920 | 90148472 | 209.89 |
| METHOD OF PAYMENT | | | | |
| <input type="checkbox"/> | CHECK ENCLOSED | AMOUNT PAID | | <input type="checkbox"/> |
| <input type="checkbox"/> | CHARGE MY CREDIT CARD | SIGNATURE | | <input type="checkbox"/> |
| EXPIRATION CARD NO. | <input type="text"/> | INTERBANK NO. (MC ONLY) | | <input type="checkbox"/> |
| <input type="checkbox"/> | | <input type="checkbox"/> | AMEX | |
| | | <input type="checkbox"/> | VISA | |
| | | <input type="checkbox"/> | MASTERCARD | |

For Easy Payment
 Complete Credit Card
 Information or Call
 1-800-782-8399

00100000706920090348514730000000209896



State Chemical Solutions
 5915 Landerbrook Drive Suite 300
 Mayfield Heights, Ohio 44124
 www.statechemical.com
 Phone: 440-565-5555 Fax: 1-888-771-9670
 A Division Of State Industrial Products Corp.

Invoice

| Document No. | Document Date | Due Date |
|--------------|---------------|------------|
| 903417174 | 07/12/2024 | 08/11/2024 |

We have no Fax number on file.
 Our Customer Service Phone number is: 1-800-782-2436

BILL TO:
 Customer No.: 706920

SWEET WATER FITNESS CENTER
C/O MARSHALL CREEK CDD
1865 N LOOP PKWY
SAINT AUGUSTINE, FL 32095-6842
USA

SHIP TO:

SWEET WATER FITNESS CENTER
C/O MARSHALL CREEK CDD
1865 N LOOP PKWY
SAINT AUGUSTINE, FL
32095-6842



001010 Safety Data Sheets are available at <http://statechemical.com/safety-data-sheets>

| Open Qty | | Ord Qty | | Ship Qty | | U M | | Item | | Description | | Unit Price | | Extended Price | |
|----------|--|---------|--|----------|--|-----|--|--------|--|------------------------|--|------------|--|----------------|--|
| 0 | | 1 | | 1 | | CS | | 128036 | | SHOWER N GO 1000ML CS6 | | 209.890 | | 209.89 | |

RECEIVED
 OCT 02 2024
 BY: _____

- IMPORTANT: Please return remittance portion below with your payment.
 - All tax exempt customers must submit a tax exempt certificate with payment.
 - Claims for shortage or damaged goods must be made within 5 days after receipt of goods.
 - No returns without a Return Goods Authorization.
 - Contact Customer Service concerning invoices, damaged product, or returns at 1-800-782-2436.
- Our Federal Tax ID: 34-0552740

| Net Sales | Shipping&Processing | Sales Tax | TOTAL |
|-----------|---------------------|-----------|--------|
| 209.89 | 0.00 | 0.00 | 209.89 |

PAY NO MONEY TO ACCOUNT MANAGER

FOR CHEMICAL EMERGENCY SPILL,
 LEAK, FIRE, EXPOSURE OR ACCIDENT
 CALL CHEMTREC 24/7 AT (800)
 424-9300.

PLEASE DETACH AND RETURN WITH PAYMENT

Please update your remittance information as shown below.

Make Checks Payable to:
State Industrial Products

REMITTANCE INFORMATION
 P.O. BOX 830316
 Philadelphia, PA
 19182-0316

| Invoice No | Due Date | Customer No | Acct Mgr | Total Due |
|------------|------------|-------------|----------|-----------|
| 903417174 | 08/11/2024 | 706920 | 90148472 | 209.89 |

METHOD OF PAYMENT

CHECK ENCLOSED AMEX

CHARGE MY CREDIT CARD VISA

MASTERCARD

AMOUNT PAID _____

EXPIRATION CARD NO. [] [] [] [] SIGNATURE _____

INTERBANK NO. (MC ONLY) _____

For Easy Payment
 Complete Credit Card
 Information or Call
 1-800-782-8399

00100000706920090341717400000000209891

Sweetwater Creek CDD
1865 North Loop Pkwy,
Saint Augustine, FL, 32095

Vendor: Tiffany Cunningham
153 Esmerelda Rd, St. Augustine, FL 32095

2023 Classes Taught in TWO week period: 10/6 - 10/19

(3)



Cardio X Dates: 10/8/24
10/15/24

Substitute Dates: 10/17/24

Code: 2-340-53800-34500

Cost: \$ 105⁰⁰

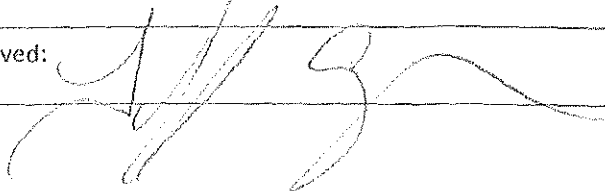
RECEIVED
OCT 18 2024
BY: _____

Approved: 

Date: 10/17/24

Sweetwater Creek CDD
1865 North Loop Pkwy,
Saint Augustine, Fl, 32095

Vendor: Tiffany Cunningham

153 Esmerelda Rd, St. Augustine, Fl 32095

2023 Classes Taught in TWO week period: ⁽¹⁾

9-19-24

Cardio X Dates:



Substitute Dates:

had subs for my classes
week of 9/8 and on 9-17

Code: 2-340-53800-34500

Cost:

3500

RECEIVED
OCT 04 2024
BY: _____

Approved:

Date:

9/19/24

Sweetwater Creek CDD
1865 North Loop Pkwy,
Saint Augustine, Fl, 32095

Vendor: Tiffany Cunningham

153 Esmerelda Rd, St. Augustine, Fl 32095

2023 Classes Taught in TWO week period:

9/22 - 10/5

Cardio X Dates:

9/24

9/20

Substitute Dates:

10/1

10/3

Code: 2-340-53800-34500

Cost:

\$140⁰⁰

RECEIVED
OCT 04 2024
BY: _____

Approved:

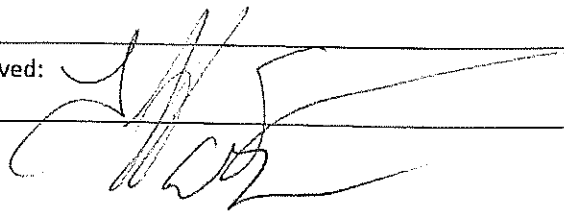

Date:

10/3/24



210 Handyman Services, LLC

315-726-2975 | paul@210handymanservices.com | www.210handymanservices.com

RECIPIENT:

Sweetwater Creek CDD Supervisors and Staff

1865 North Loop Parkway
St. Augustine, Florida 32095

Estimate #183

Sent on Jul 10, 2024

Total \$5,200.00

| Product/Service | Description | Qty. | Unit Price | Total |
|--------------------------|--|------|------------|------------|
| Refinish Hardwood Floors | Refinishing Services: - Sanding floors - Application of 4 coats of polyurethane - Sealing | 1 | \$5,200.00 | \$5,200.00 |

Thank you.

A deposit of \$2,600.00 will be required to begin.

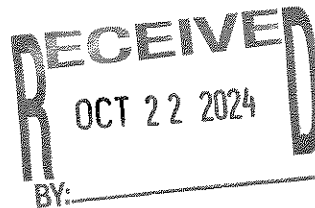

Sep 18, 2024

Date

Client Signature

Total

\$5,200.00

This quote is valid for the next 30 days, after which values may be subject to change.

By booking your project, you agree to our Policies and Procedures Agreement. Please ensure to review the agreement before booking. Let us know if you have any questions or concerns.

AP300R
*** CHECK NOS. 000038-000038

YEAR-TO-DATE ACCOUNTS PAYABLE PREPAID/COMPUTER CHECK REGISTER
SWEETWATER CREEK-CAPITAL RSRVE
BANK A CAPITAL RESERVE FUND

RUN 11/25/24

PAGE 1

| CHECK DATE | VEND# |INVOICE..... DATE INVOICE | ...EXPENSED TO... YRMO DPT ACCT# SUB SUBCLASS | VENDOR NAME | STATUS | AMOUNT |CHECK..... AMOUNT # |
|---------------|-------|-----------------------------------|---|-----------------------------|--------|--------------------|----------------------------|
| 10/03/24 | 00008 | 9/23/24 28632 | 202409 600-58400-61000 ST ENT REDESIGN PH2-FLWRS | DUVAL LANDSCAPE MAINTENANCE | * | 20,863.28 | 20,863.28 000038 |
| ----- | | | | | | TOTAL FOR BANK A | 20,863.28 |
| | | | | | | TOTAL FOR REGISTER | 20,863.28 |



Duval Landscape Maintenance
 7011 Business Park Blvd N
 Jacksonville, FL 32256
 www.duvallandscape.com

INVOICE

| Date | Invoice No. |
|----------|-------------|
| 09/23/24 | 28632 |
| Terms | Due Date |
| Net 40 | 11/02/24 |

| BILL TO |
|---|
| Sweetwater Community Development District 475 West Town Place, Suite 114 |

| PROPERTY |
|--|
| Sweetwater Creek CDD 605 Palencia Club Dr |

| Amount Due | PO Number |
|-------------|-----------|
| \$20,863.28 | |

Please detach top portion and return with your payment.

| DESCRIPTION | UOM | QTY | UNIT PRICE | EXT PRICE | TOTAL |
|-------------|-----|-----|------------|-----------|-------|
|-------------|-----|-----|------------|-----------|-------|

#32214 - Street Entrances Redesign -
 Phase 2 - Removal of Flower Beds

Street Entrances Redesign - Phase 2 -
 Removal of Flower Beds:

Area 1 - Left Side of Rincon at
 Ensenada -- Flowers to be removed by
 Maintenance Crew. Installation of half a
 pallet of sod where flowers were planted
 previously. In current landscaping bed,
 addition of 60 Blue Daze.

RECEIVED
 SEP 23 2024
 BY: _____

Area 2 - Right Side of Rincon at
 Ensenade -- Flowers to be removed by
 Maintenance Crew. Installation of half a
 pallet of sod where flowers were planted
 previously. In current landscaping bed,
 addition of 60 Blue Daze.

Area 3 - Left Side of Otero at Las
 Calinas -- Flowers to be removed by
 Maintenance Crew. Addition of 30 Blue

Daze.

Area 4 - Right Side of Otero at Las Calinas -- Flowers to be removed by Maintenance Crew. Addition of 30 Blue Daze.

Area 5 - Left Side of Lazo at Las Calinas - Flowers to be removed by Maintenance Crew. Installation of 18 Red Fountain Grasses and 40 Blue Daze. Note exact corners are not to be sodded at this time until flax lilies and grasses are transplanted throughout community.

Area 6 - Right Side of Lazo at Las Calinas -- Installation of 18 Red Fountain Grasses and 40 Blue Daze. Note exact corners are not to be sodded at this time until flax lilies and grasses are transplanted throughout community.

Area 7 - Left Side of Glorieta at Las Calinas -- Flowers to be removed by Maintenance Crew. Installation of half a pallet of sod where flowers were planted previously. In current landscaping bed, addition of 60 Blue Daze.

Area 8 - Right Side of Glorieta at Las Calinas -- Flowers to be removed by Maintenance Crew. Installation of half a pallet of sod where flowers were planted previously. In current landscaping bed, addition of 60 Blue Daze.

Area 9 - Left Side of Brasilia at Glorieta -
- Maintenance crew to transplant Variegated Flax Lilies in the community. Maintenance crew to move grasses to new design. Addition of 18 Red

Fountain Grasses and 80 Blue Daze.

Area 10 - Right Side of Brasilia at Glorieta -- Maintenance crew to transplant Variegated Flax Lilies in the community. Addition of 18 Red Fountain Grasses and 80 Blue Daze.

Area 11 - Left Side of Codo at Las Calinas -
- Flowers to be removed by Maintenance Crew. Installation of 40 Blue Daze.

Area 12 - Right Side of Codo at Las Calinas -- Flowers to be removed by Maintenance Crew. Installation of 40 Blue Daze.

Area 13 - Left Side of Dosel at Las Calinas -
- Flowers to be removed by Maintenance Crew. Installation of half a pallet of sod. Installation of 60 Blue Daze.

Area 14 - Right Side of Dosel at Las Calinas -- Flowers to be removed by Maintenance Crew. Installation of half a pallet of sod. Installation of 60 Blue Daze.

Area 15 - Left Side of Barbella at Las Calinas -- Flowers to be removed by Maintenance Crew. Installation of 40 Blue Daze.

Area 16 - Right Side of Barbella at Las Calinas -- Flowers to be removed by Maintenance Crew. Installation of 40 Blue Daze.

Area 17 - Left Side of Pantano Vista Way at Rio Del Norte -- Flowers to be removed by Maintenance Crew. Installation of a pallet of sod. Define tree rings around Magnolia Trees (3). Limb up Magnolia Trees (3). Under Magnolia Trees, add

D.

**SWEETWATER CREEK COMMUNITY DEVELOPMENT DISTRICT
SPECIAL ASSESSMENT BONDS, SERIES 2019**

The undersigned, an Authorized Officer of Sweetwater Creek Community Development District (the "District") hereby submits the following requisition for disbursement under and pursuant to the terms of the Master Trust Indenture from the District to U.S. Bank National Association, Orlando, Florida, as trustee (the "Trustee"), dated as of July 1, 2019 (the "Master Indenture"), as amended and supplemented by the First Supplemental Trust Indenture from the District to the Trustee, dated as of July 1, 2019 (the Master Indenture as amended and supplemented is hereinafter referred to as the "Indenture") (all capitalized terms used herein shall have the meaning ascribed to such term in the Indenture):

(A) Requisition Number: 143

(B) Name and address of Payee: Sweetwater Creek CDD
475 West Town Place Ste 114
St Augustine FL 32092

(C) Amount Payable: \$15,810.12

(D) Purpose for which paid or incurred (refer also to specific contract if amount is due and payable pursuant to a contract involving progress payments, or, state Costs of Issuance, if applicable): Envera System system upgrade deposit and install balance.

(E) Fund or Account and subaccount, if any, from which disbursement to be made: Series 2019 Construction Account

The undersigned hereby certifies that:

obligations in the stated amount set forth above have been incurred by the District, that each disbursement set forth above is a proper charge against the Series 2019A Acquisition and Construction Account and the subaccount, if any, referenced above, that each disbursement set forth above was incurred in connection with the acquisition and construction of the Series 2019 Project and each represents a Cost of the Series 2019 Project, and has not previously been paid

OR

this requisition is for Costs of Issuance payable from the Costs of Issuance Account that has not previously been paid.

The undersigned hereby further certifies that there has not been filed with or served upon the District notice of any lien, right to lien, or attachment upon, or claim affecting the right to receive payment of, any of the moneys payable to the Payee set forth above, which has not been released or will not be released simultaneously with the payment hereof.

The undersigned hereby further certifies that such requisition contains no item representing payment on account of any retained percentage which the District is at the date of such certificate entitled to retain.

Originals or copies of the invoice(s) from the vendor of the property acquired or services rendered with respect to which disbursement is hereby requested are on file with the District.

**SWEETWATER CREEK COMMUNITY
DEVELOPMENT DISTRICT**

By: 
Authorized Officer

**CONSULTING ENGINEER'S APPROVAL FOR
NON-COST OF ISSUANCE REQUESTS ONLY**

If this requisition is for a disbursement from other than the Costs of Issuance Account, the undersigned Consulting Engineer hereby certifies that this disbursement is for a Cost of the Series 2019 Project and is consistent with: (i) the applicable acquisition or construction contract; (ii) the plans and specifications for the portion of the Series 2019 Project with respect to which such disbursement is being made; and (iii) the report of the Consulting Engineer attached as an exhibit to the First Supplemental Indenture, as such report shall have been amended or modified on the date hereof.

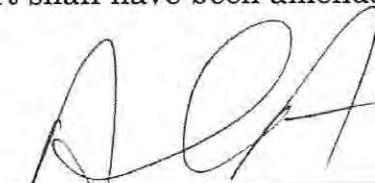
Consulting Engineer



Invoice

| | |
|----------------|--------------|
| Page | 1/1 |
| Date | 3/20/2024 |
| Reference | |
| Invoice Number | INV000007172 |

Hidden Eyes LLC
 d/b/a Envera Systems
 P.O. Box 2086
 Hicksville, NY 11802
 (941) 556-0743

Bill To
 Sweetwater Creek CDD
 c/o GMS
 475 West Town Place, Suite 114
 St. Augustine, FL, 32092

Site
 Sweetwater Creek CDD
 1187 Las Calinas Blvd
 St. Augustine, FL, 32095

| Bill To Number | Document Number | Type | Site Number | Entered By | Customer Reference | Weight |
|----------------|-----------------|------|-------------|------------|--------------------|--------|
| 002604 | C-2898 | INS | 002604G | SCHREIG | | 0.0000 |

| Code / Description | Supply | Unit | Unit Price | Discount | Unit Tax | Ext. |
|-------------------------------|--------|------|------------|----------|----------|----------|
| INS-BD Install Balance Due | 1 | EA | 7,905.06 | 0.00 | 0.00 | 7,905.06 |

If terms permit, where paying by check
 Please make payable to Envera Systems
 Remit to: P.O. Box 2086 Hicksville, NY 11802

Tax Summary
 STJN 0.00

| | |
|------------------------|-----------------|
| Services | 7,905.06 |
| Items | 0.00 |
| Subtotal | 7,905.06 |
| Less Discount | 0.00 |
| Less Cover | 0.00 |
| Plus Excl. Tax | 0.00 |
| Less Payment | |
| Total Due (USD) | 7,905.06 |

Due Date: 4/19/2024

Terms: Net 30 Days



ENVERA
 Hidden Eyes LLC
 d/b/a Envera Systems
 P.O. Box 2086
 Hicksville, NY 11802

| | |
|---------|------------|
| Number: | IN00003047 |
| Page: | 1 |
| Date: | 11/7/2023 |

| | |
|-------------|--|
| Sold | Sweetwater Creek CDD |
| To: | c/o GMS 475 West Town Place, Suite 114 St. Augustine, FL 32092 |

| | |
|-------------|---|
| Ship | Gates |
| To: | North Loop/South Loop Parkway Palencia North Entrance St. Augustine, FL 32095 |

| | | | | |
|----------------------|--------------|-------------|----------|------------|
| Reference - P.O. No. | Customer No. | Salesperson | Ship Via | Terms Code |
| | 002604D | | | ONRCP |

| Item No. | Description/Comments | Quantity | UOM | Unit Price | Amount |
|-----------------|------------------------|----------|-----|------------|----------|
| UPGRADE DEPOSIT | System Upgrade Deposit | 1 | EA | 15,810.12 | 7,905.06 |

Remit To:
Hidden Eyes LLC
 d/b/a Envera Systems
 P.O. Box 2086
 Hicksville, NY 11802

| | |
|-----------------------|----------|
| Subtotal before taxes | 7,905.06 |
| Total taxes | 0.00 |
| Total amount | 7,905.06 |
| Credit Amount | 0.00 |
| Payment received | 0.00 |
| Discount taken | 0.00 |
| Amount due | 7,905.06 |

Invoice

FIFTH ORDER OF BUSINESS

A.



**DUVAL
LANDSCAPE
MAINTENANCE, LLC**

With

**Sweetwater Creek
Community Development
District**

**Monthly Reporting
November 2024**



DUVAL LANDSCAPE MAINTENANCE, LLC

Monthly Reporting November 2024

In Progress:

1. Bi-weekly mowing continues through March 31st.
2. Sod repairs at Duval's cost.
3. Select areas beyond round-a-bout to receive top soil top dressing.
4. Filled in holes under benches at dog park. We will monitor this as we maintain these areas going forward.
5. Tree trimming/lifting, woodline push backs.

Completed:

1. Removal of grasses on some cut throughs on Glorieta Drive.
2. Rock and pinestraw installation at fitness center.
3. Fall Pinestraw.
4. Dirt installation to recently repaired sidewalk. Transplant liriopoe to this area.
5. Remove poor looking plant material at round-a-bout transplant select plants to the berm around the basketball court at Ensenada Park.
6. Red and White SnapDragon flowers have been installed.
7. Weekly Communication Reports for Maintenance Crew and Fertilization and Pest Control Division.

Discussion:

- 1.

Attachments:

1. The Irrigation Wet Check Reports with summary on each report for November 2024 are attached. Onda Soccerfield did not wet check.
2. Middle Lift Station controller not checked as it was down during inspections. (Proposal for repair attached)
3. Two irrigation proposals.

Thank you,

YOUR DUVAL TEAM

Michael Wooldridge
Branch Manager

Preston Moody
Irrigation Manager

Torre Dunham
Fertilization Manager



November 22, 2024
Sweetwater Creek CDD

Contract No. - 34666

sweetwater middle clock decoder repairs nov24

| ITEM | QTY | UNIT PRICE | TOTAL PRICE |
|--------------------------|------|------------|-------------------|
| Hunter 1 Station Decoder | 2.00 | \$285.00 | \$570.00 |
| Misc Irrigation Supplies | 1.00 | \$30.00 | \$30.00 |
| Valve Locating | 2.00 | \$150.00 | \$300.00 |
| Irrigation Labor | 3.00 | \$100.00 | \$300.00 |
| | | | \$1,200.00 |

WORK ORDER SUMMARY

| SERVICES | SALES TAX | TOTAL PRICE |
|----------------------------|-----------|-------------------|
| Irrigation Service/Repairs | \$0.00 | \$1,200.00 |
| | | \$0.00 |
| | | \$1,200.00 |

| | |
|------------------|-------------------|
| Sale | \$1,200.00 |
| Sales Tax | \$0.00 |
| Total | \$1,200.00 |

By _____

Preston Moody

Date 11/22/2024

Duval Landscape Maintenance

By _____

Date _____

Sweetwater Creek CDD



November 22, 2024
Sweetwater Creek CDD

Contract No. - 34665

sweetwater Rincon valve repair nov24

| ITEM | QTY | UNIT PRICE | TOTAL PRICE |
|--------------------------|------|------------|-----------------|
| Electrical Valve | 2.00 | \$225.00 | \$450.00 |
| Slip fix | 2.00 | \$75.00 | \$150.00 |
| Misc Irrigation Supplies | 1.00 | \$100.00 | \$100.00 |
| | | | \$700.00 |

WORK ORDER SUMMARY

| SERVICES | SALES TAX | TOTAL PRICE |
|----------------------------|-----------|-----------------|
| Irrigation Service/Repairs | \$0.00 | \$700.00 |
| | | \$0.00 |
| | | \$700.00 |

| | |
|------------------|-----------------|
| Sale | \$700.00 |
| Sales Tax | \$0.00 |
| Total | \$700.00 |

By _____

Preston Moody

Date 11/22/2024 _____

Duval Landscape Maintenance

By _____

Date _____

Sweetwater Creek CDD



Duval Landscape

MAINTENANCE

Irrigation Technical Inspection Report

| Irrigation Controller | | | Point of Connection | | | Site Name | | SweetWater | | | | | | | |
|-----------------------|------|-------------|---------------------|------|-------------|------------|--------------|------------|------------|---|---|---|----|---|---|
| Location | | Behind sign | Location | | Behind sign | Location | | Mini putt | | | | | | | |
| Type | | RB | | Size | | Technician | | Preston | | | | | | | |
| Rain Guage | Y | N | Source | | Meter | Well | Date | | 11/21/2024 | | | | | | |
| Power on | Y | N | Backflow | | | Program | | A | B | C | | | | | |
| General Information | | | PRV | | Y | N | Start Times | | 10:00 P | | | | | | |
| Valve Type | | | MV | | Y | N | Run Times | | 2Hrs | | | | | | |
| Coverage | Good | | | | Y | N | Days of Week | | S | M | T | W | Th | F | S |

| Zone | Head Type | Turf | Shrub | Flowers | Lateral Line Break | Zone Not Responding | Low pressure | Zone not Shutting Down | 4" Spray | 6" Spray | 12" Spray | 4" Rotor | Fixed Riser | Cleaned/Replaced Nozzle | Adjus | Straightened | Capped | Raised/Lowered | Locations of Zones |
|------|-----------|------|-------|---------|--------------------|---------------------|--------------|------------------------|----------|----------|-----------|----------|-------------|-------------------------|-------|--------------|--------|----------------|--------------------------------|
| 1 | s | x | x | | | | | | | | 1 | | | 1 | x | | | | Curb sidewalk in front of sign |
| 2 | r | x | x | | | | | | | | | | | | x | | | | Around sign |
| 3 | r | x | x | | | | | | | | | | | | x | | | | Grass area BTW sign and flag |
| 4 | s | x | x | | | | | | | | | | | | x | | | | Left side of putt putt |
| 5 | D | x | x | | | | | | | | | | | | | | | | Planrs at putt putt |
| 6 | r | x | x | | | | | | | | | | | | x | | | | Back side of island |
| 7 | s | x | x | | | | | | | | | | | | x | | | | Front sign |
| | | | | | | | | | | | | | | | | | | | |
| | | | | | | | | | | | | | | | | | | | |
| | | | | | | | | | | | | | | | | | | | |
| | | | | | | | | | | | | | | | | | | | |
| | | | | | | | | | | | | | | | | | | | |
| | | | | | | | | | | | | | | | | | | | |

Comments: Nothing wrong other than regular maintenance items





Duval Landscape

MAINTENANCE

Irrigation Technical Inspection Report

| Irrigation Controller | | | Point of Connection | | | Site Name | SweetWater | | | | | | |
|-----------------------|------------|---|---------------------|------------|------|--------------|--------------------|----------|---------|---|----|---|---|
| Location | Right lake | | Location | Right lake | | Location | Torcido controller | | | | | | |
| Type | RB | | Size | | | Technician | Preston | | | | | | |
| Rain Guage | Y | N | Source | Meter | Well | Date | 11/21/2024 | | | | | | |
| Power on | Y | N | | | | Program | A | B | C | | | | |
| General Information | | | Backflow | | | Start Times | 10:00 PM | 10:00 PM | 8:00 PM | | | | |
| Valve Type | | | PRV | Y | N | Run times | 3H10M | 3H20M | 30M | | | | |
| Coverage | Good | | MV | Y | N | Days of Week | S | M | T | W | Th | F | S |

| Zone | Head Type | Turf | Shrub | Flowers | Lateral Line Break | Zone Not Responding | Low pressure | Zone not Shutting Down | 4" Spray | 6" Spray | 12" Spray | 4" Rotor | Fixed Riser | Cleaned/Replaced Nozzle | Adjusted Spray Pattern | Straightened | Capped | Raised/Lowered | Locations of Zones |
|------|-----------|------|-------|---------|--------------------|---------------------|--------------|------------------------|----------|----------|-----------|----------|-------------|-------------------------|------------------------|--------------|--------|----------------|-----------------------------------|
| 1 | s | x | x | | | | | | | | | | | | | | | | Island front of clubhouse |
| 2 | s | x | x | | | | | | | | | | | x | | | | | Behind Amenity center |
| 3 | | | | | | | | | | | | | | | | | | | no wire |
| 4 | r | x | x | | | | | | | | | | | x | | | | | Next to pickle ball court |
| 5 | r | x | x | | | | | | | | | | | x | | | | | Woodline back of clubhouse |
| 6 | r | x | x | | | | | | | | | | | x | | | | | entry |
| 7 | s | x | x | | | | | | | | | | | x | | | | | Front of aminity center left side |
| 8 | r | x | x | | | | | | | | | | | x | | | | | Back Parking Lot |
| 9 | s | x | x | | | | | | | | | | | x | | | | | At pool pump |
| 10 | s | x | x | | | | | | | | | | | x | | | | | At pool pump |
| 11 | s | x | x | | | | | | | | | | | x | | | | | Back fence behind pool |
| 12 | | | | | | | | | | | | | | | | | | | No wire |
| 13 | | | | | | | | | | | | | | | | | | | no wire |
| 14 | s | x | x | | | | | | | | | | | x | | | | | Ensanada Flowers |
| 15 | s | x | x | | | | | | | | | | | x | | | | | Ensanada Curb |
| 16 | s | x | x | | | | | | | | | | | x | | | | | Ensanada Medio-across st |
| 17 | s | x | x | | | | | | | | | | | x | | | | | Ensanada Across st |
| 18 | s | x | x | | | | | | | | | | | x | | | | | Torcido shrubs 80-140 |
| 19 | s | x | x | | | | | | | | | | | x | | | | | Torcido turf 80-end |
| 20 | s | x | x | | | | | | | | | | | x | | | | | Torcido shrubs 140-end |
| 21 | r | x | x | | | | | | | | 2 | | | x | | | | | Park |

Comments: General Maintenance
 Zone not shutting down. Repaired Same day





Duval Landscape MAINTENANCE

Irrigation Technical Inspection Report

| Irrigation Controller | | | Point of Connection | | | Site Name | | SweetWater | | | | | |
|-----------------------|-----------|---|---------------------|--------------------|------|--------------|--------------------|------------|---|---|----|---|---|
| Location | Lft Round | | Location | Left of roundabout | | Location | Left of roundabout | | | | | | |
| Type | RB | | Size | | | Technician | Preston | | | | | | |
| Rain Guage | Y | N | Source | Meter | Well | Date | 11/21/2024 | | | | | | |
| Power on | Y | N | | | | Program | A | B | C | | | | |
| General Information | | | Backflow | | | Start Times | 10:00 P | | | | | | |
| Valve Type | | | PRV | Y | N | Run times | 2H20M | | | | | | |
| Coverage | Good | | MV | Y | N | Days of Week | S | M | T | W | Th | F | S |

| Zone | Head Type | Turf | Shrub | Flowers | Lateral Line Break | Zone Not Responding | Low pressure | Zone not Shutting Down | 4" Spray | 6" Spray | 12" Spray | 4" Rotor | Fixed Riser | Cleaned/Replaced Nozzle | Adjusted Spray Pattern | Straightened | Capped | Raised/Lowered | Locations of Zones |
|------|-----------|------|-------|---------|--------------------|---------------------|--------------|------------------------|----------|----------|-----------|----------|-------------|-------------------------|------------------------|--------------|--------|----------------|----------------------------------|
| 1 | s | x | x | | | | | | | | | | | x | | | | | Right of endrede |
| 2 | r | x | x | x | | | | | | | | 1 | | x | | | | | Right of endrede back sidewalk |
| 3 | s | x | x | | | | | | | | | | | x | | | | | Middle btw endred + Roundabout |
| 4 | r | x | x | | | | | | | | | | | x | | | | | Back of sidewalk left roundabout |
| 5 | s | x | x | | | | | | | | | | | x | | | | | Btw curb and sidewalk Left |
| 6 | s | x | x | | | | | | | | | | | 2 | x | | | | Left of the roundabout |

Comments: Nothing wrong other than regular maintenance items



Duval Landscape
MAINTENANCE



Duval Landscape

MAINTENANCE

Irrigation Technical Inspection Report

| Irrigation Controller | | | Point of Connection | | | Site Name | | SweetWater | | | | | | | |
|-----------------------|--|--------------|---------------------|---------|--------------|-------------|--------------|-----------------|---------|------------|---|---|----|---|---|
| Location | | Right corner | Location | | Right corner | Location | | Barbells Circle | | | | | | | |
| Type | | RB | | Size | | Technician | | Preston | | | | | | | |
| Rain Guage | | Y | N | Source | | Meter | Well | Date | | 11/21/2024 | | | | | |
| Power on | | Y | N | Program | | | A | B | C | | | | | | |
| General Information | | | Backflow | | | Start Times | | 10:00 P | 12:00 P | | | | | | |
| Valve Type | | PRV | | Y | N | Run times | | 5H20M | 40M | | | | | | |
| Coverage | | Good | | MV | Y | N | Days of Week | | S | M | T | W | Th | F | S |

| Zone | Head Type | Turf | Shrub | Flowers | Lateral Line Break | Zone Not Responding | Low pressure | Zone not Shutting Down | 4" Spray | 6" Spray | 12" Spray | 4" Rotor | Fixed Riser | Cleaned/Replaced Nozzle | Adjusted Spray Pattern | Straightened | Capped | Raised/Lowered | Locations of Zones |
|------|-----------|------|-------|---------|--------------------|---------------------|--------------|------------------------|----------|----------|-----------|----------|-------------|-------------------------|------------------------|--------------|--------|----------------|------------------------------------|
| 1 | s | x | x | | | | | | | | | | | x | | | | | BTW curb and sidewalk Calle de |
| 2 | s | x | x | | | | | | | | | | | x | | | | | BTW curb and sidewalk left |
| 3 | s | x | x | | | | | | 1 | | | | | 1 | x | | | | Right corner of Calle de paz |
| 4 | s | x | x | x | | | | | | | | | | x | | | | | Corner of barbella |
| 5 | r | x | x | x | | | | | | | | | | x | | | | | Acrooss from controller |
| 6 | r | x | x | | | | | | | | | | | x | | | | | Across from controller |
| 7 | s | x | x | | | | | | | | | | | x | | | | | Across from controller/pond |
| 8 | r | x | x | | | | | | | | | | | x | | | | | Along sidewalk by controller |
| 9 | s | x | x | | | | | | | | | | | x | | | | | Along curb left side |
| 10 | s | x | x | | | | | | | | | | | x | | | | | Right side along sidewalk Barbells |
| 11 | s | x | x | x | | | | | | | | | | x | | | | | Along curb right side |
| 12 | r | x | x | x | | | | | | | | 1 | | x | | | | | Left side of barbella |
| 13 | s | x | x | | 1 | | | | | | | | | x | | | | | Back of sidewalk Right side |
| 14 | d | x | x | | | | | | | | | | | x | | | | | Drip for trees |
| 15 | d | x | x | | | | | | | | | | | x | | | | | Drip for trees |

Comments: Broken bubbler lines
 2 Zones non operational Completed 10/18



Duval Landscape
 MAINTENANCE



Duval Landscape

MAINTENANCE

Irrigation Technical Inspection Report

| Irrigation Controller | | | Point of Connection | | | Site Name | SweetWater | | | | | | |
|-----------------------|-----------|---|---------------------|-------|------|--------------|---------------------------|---|---|---|----|---|---|
| Location | Lake bank | | Location | | | Location | Brasilia + Glorieta Drive | | | | | | |
| Type | RB | | Size | | | Technician | Preston | | | | | | |
| Rain Guage | Y | N | Source | Meter | Well | Date | 11/21/2024 | | | | | | |
| Power on | Y | N | | | | Program | A | B | C | | | | |
| General Information | | | Backflow | | | Start Times | 10:00 P | | | | | | |
| Valve Type | | | PRV | Y | N | Run times | 2H40M | | | | | | |
| Coverage | Good | | MV | Y | N | Days of Week | S | M | T | W | Th | F | S |

| Zone | Head Type | Turf | Shrub | Flowers | Lateral Line Break | Zone Not Responding | Valve Leaking | Zone not Shutting Down | 4" Spray | 6" Spray | 12" Spray | 4" Rotor | Fixed Riser | Cleaned/Replaced Nozzle | Adjusted Spray Pattern | Straightened | Capped | Raised/Lowered | Locations of Zones |
|------|-----------|------|-------|---------|--------------------|---------------------|---------------|------------------------|----------|----------|-----------|----------|-------------|-------------------------|------------------------|--------------|--------|----------------|------------------------------------|
| 1 | s | x | x | | | | | | | | | | | | x | | | | Left corner of brasilia |
| 2 | s | x | x | x | | | | | | | | | | | x | | | | Btw curb and sidewalk lft brasilia |
| 3 | r | x | x | | | | | | | | | | | | x | | | | Back curb left of brasilia |
| 4 | s | x | x | | | | | | | | | | | | x | | | | Right corner of brasilia |
| 5 | r | x | x | | | | | | | | | | | | x | | | | Back of sidewalk right side |
| 6 | s | x | x | | | | | | | | | | | | x | | | | Btw curb and sidewalk Right |
| 7 | r | x | x | | | | | | | | | | | | x | | | | Back of sidewalk right side |

Comment: Nothing was wrong



Duval Landscape
MAINTENANCE



Duval Landscape

MAINTENANCE

Irrigation Technical Inspection Report

| | | | | | | | | | | | | | | |
|-----------------------|---|--------------|---------------------|---|--------------|--------------|------|---------------|------------|---|---|----|---|---|
| Irrigation Controller | | | Point of Connection | | | Site Name | | Del norte | | | | | | |
| Location | | Lift station | Location | | Lift station | Location | | Rio Del norte | | | | | | |
| Type | | Hunter | Size | | 5hp | Technician | | Preston | | | | | | |
| Rain Guage | Y | N | Source | | Meter | Well | Date | | 11/22/2024 | | | | | |
| Power on | Y | N | Program | | | A | B | C | | | | | | |
| General Information | | | Backflow | | | Start Times | | 10:00 P | 12:00 P | | | | | |
| Valve Type | | | PRV | Y | N | Run Time | | 1H40M | 30Min | | | | | |
| Coverage | | Good | MV | Y | N | Days of Week | | S | M | T | W | Th | F | S |

| Zone | Head Type | Turf | Shrub | Flowers | Lateral Line Break | Zone Not Responding | Low pressure | Zone not Shutting Down | 4" Spray | 6" Spray | 12" Spray | 4" Rotor | Fixed Riser | Cleaned/Replaced Nozzle | Adjusted Spray Pattern | Straightened | Capped | Raised/Lowered | Locations of Zones |
|------|-----------|------|-------|---------|--------------------|---------------------|--------------|------------------------|----------|----------|-----------|----------|-------------|-------------------------|------------------------|--------------|--------|----------------|-----------------------------|
| 1 | | | | | | | | | | | | | | | | | | | |
| 2 | r | x | x | | | | | | | | | | | x | | | | | Island back of Del norte |
| 3 | s | x | x | x | | | | | | | | | | x | | | | | Both sides at stop sign |
| 4 | r | x | x | x | | | | | | | | | | x | | | | | Right side back of sidewalk |
| 5 | r | x | x | | | | | | | | | | | x | | | | | Island at mailboxes |

Comments: Regular maintenance-



Duval Landscape
MAINTENANCE



Duval Landscape

MAINTENANCE

Irrigation Technical Inspection Report

| | | | | | | | | | | | | | | | |
|-----------------------|--|-----------------|---------------------|--------|-----------------|-------------|--------------|----------------------|----------|------------|-----|---|----|---|---|
| Irrigation Controller | | | Point of Connection | | | Site Name | | SweetWater | | | | | | | |
| Location | | Right of circle | Location | | Right of circle | Location | | Right of round about | | | | | | | |
| Type | | RB | Size | | | Technician | | Preston | | | | | | | |
| Rain Guage | | Y | N | Source | | Meter | Well | Date | | 11/21/2024 | | | | | |
| Power on | | Y | N | | | | | Program | | A | B | C | | | |
| General Information | | | Backflow | | | Start Times | | 10:00 PM | 10:00 PM | 12:00 PM | | | | | |
| Valve Type | | | PRV | | Y | N | Run Times | | 4H30M | 8H10M | 20M | | | | |
| Coverage | | Good | MV | | Y | N | Days of Week | | S | M | T | W | Th | F | S |

| Zone | Head Type | Turf | Shrub | Flowers | Lateral Line Break | Zone Not Responding | Low pressure | Zone not Shutting Down | 4" Spray | 6" Spray | 12" Spray | 4" Rotor | Fixed Riser | Cleaned/Replaced Nozzle | Adjusted Spray Pattern | Straightened | Capped | Raised/Lowered | Locations of Zones |
|------|-----------|------|-------|---------|--------------------|---------------------|--------------|------------------------|----------|----------|-----------|----------|-------------|-------------------------|------------------------|--------------|--------|----------------|----------------------------------|
| 1 | r | x | x | | | | | | | | | | | x | | | | | Center of round about |
| 2 | s | x | x | | | | | | | | | | | x | | | | | Along curb right of lazo court |
| 3 | s | x | x | | | | | | | | | | | x | | | | | Along sidewalk left of enrede |
| 4 | s | x | x | x | | | | | | | | | | x | | | | | Right of lazo along sidewalk |
| 5 | s | x | x | x | | | | | 1 | | | | | 2 | x | | | | Left of Lazo to roundabout |
| 6 | r | x | x | | | | | | | | | | | x | | | | | From lazo to roundabout |
| 7 | s | x | x | | | | | | | | | | | x | | | | | Right side of roundabout |
| 8 | r | x | x | | | | | | | | | | | x | | | | | Along berm on Ensenada |
| 9 | s | x | x | | | | | | | | | | | x | | | | | Right side between curb and walk |
| 10 | r | x | x | | | | | | | | | | | x | | | | | Along berm on Ensenada |
| 11 | s | x | x | | | | | | | | | | | x | | | | | NA |
| 12 | r | x | x | | | | | | | | | | | x | | | | | Along berm on Ensenada |
| 13 | s | x | x | | | | | | | | | | | x | | | | | Right side at bend |
| 14 | s | x | x | | | | | | | | | | | x | | | | | Right side between curb and walk |
| 15 | s | x | x | | | | | | | | | | | x | | | | | Back sidewalk right of enrede |
| 16 | s | x | x | | | | | | | | | | | x | | | | | Between curb and walk b4 enrede |
| 17 | r | x | x | | | | | | | | | 1 | | x | | | | | Between enrede and medio |
| 18 | s | x | x | | | | | | | | | | | x | | | | | Left of enrede |
| 19 | s | x | x | | | | | | | | | | | x | | | | | Right of medio on corner |
| 20 | s | x | x | | | | | | 2 | | | | | 1 | x | | | | Left of park entry |
| 21 | s | x | x | | | | | | | | | | | x | | | | | Left side along Endenada |
| 22 | s | x | x | | | | | | | | | | | x | | | | | Back sidewalk on Ensdenada |
| 23 | s | x | x | | | | | | | | | | | x | | | | | Left side along Endenada |

| | | | | | | | | | | | | | | | | | | | |
|----|---|---|---|--|--|--|--|--|--|--|--|--|--|--|---|--|--|--|----------------------------------|
| 24 | s | x | x | | | | | | | | | | | | x | | | | Left side along Endenada |
| 25 | s | x | x | | | | | | | | | | | | x | | | | Back sidewalk on Ensdanada |
| 26 | s | x | x | | | | | | | | | | | | x | | | | Left side along Endenada |
| 27 | s | x | x | | | | | | | | | | | | x | | | | Back sidewalk on Ensdanada |
| 28 | s | x | x | | | | | | | | | | | | x | | | | Left side along Endenada |
| 29 | s | x | x | | | | | | | | | | | | x | | | | back sidewalk before round about |
| 30 | s | x | x | | | | | | | | | | | | x | | | | Before round about |
| 31 | s | x | x | | | | | | | | | | | | x | | | | Right of round about |

Comments: General Maintenance





Duval Landscape

MAINTENANCE

Irrigation Technical Inspection Report

| Irrigation Controller | | | Point of Connection | | | Site Name | SweetWater | | | | | | |
|-----------------------|------------|---|---------------------|------------|------|--------------|---------------------|----------|----------|---|----|---|---|
| Location | Right lake | | Location | Right lake | | Location | Middle lift station | | | | | | |
| Type | RB | | Size | | | Technician | Preston | | | | | | |
| Rain Guage | Y | N | Source | Meter | Well | Date | 11/21/2024 | | | | | | |
| Power on | Y | N | | | | Program | A | B | C | | | | |
| General Information | | | Backflow | | | Start Times | 10:00 PM | 10:00 PM | 12:00 PM | | | | |
| Valve Type | | | PRV | Y | N | Run Times | 5H | 7H | 1H | | | | |
| Coverage | Good | | MV | Y | N | Days of Week | S | M | T | W | Th | F | S |

| Zone | Head Type | Turf | Shrub | Flowers | Lateral Line Break | Zone Not Responding | Low pressure | Zone not Shutting Down | 4" Spray | 6" Spray | 12" Spray | 4" Rotor | Fixed Riser | Cleaned/Replaced Nozzle | Adjusted Spray Pattern | Straightened | Capped | Raised/Lowered | Locations of Zones |
|------|-----------|------|-------|---------|--------------------|---------------------|--------------|------------------------|----------|----------|-----------|----------|-------------|-------------------------|------------------------|--------------|--------|----------------|------------------------------------|
| 1 | s | x | x | | | | | | | | | | | x | | | | | Left side towards round about |
| 2 | r | x | x | | | | | | | | | | | x | | | | | Right corner of Oleta |
| 3 | s | x | x | | | | | | | | | | | x | | | | | Along left sidewalk to roundabout |
| 4 | s | x | x | | | | | | | | | | | x | | | | | Along left curb Oleta to round |
| 5 | s | x | x | | | | | | | | | | | x | | | | | Along right curb Oleta to round |
| 6 | s | x | x | | | | | | | | | | | x | | | | | Along sidewalk right side |
| 7 | s | * | * | | | | | | | | | | | | | | | | Back sw ovalo las calinas |
| 8 | r | x | x | | | | | | | | | | | x | | | | | Both sides of road at lakes |
| 9 | s | x | x | | | | | | | | | | | x | | | | | Left side of Oleta |
| 10 | s | x | x | | | | | | | | | | | x | | | | | Along left side BTW Oleta+Glorieta |
| 11 | s | x | x | | | | | | | | | | | x | | | | | Along curb lift to oleta |
| 12 | s | x | x | | | | | | | | | | | x | | | | | Along sidewalk lift to oleta |
| 13 | s | x | x | | | | | | | | | | | x | | | | | Back sidewalk lift to oleta |
| 14 | r | x | x | | | | | | | | | | | x | | | | | Ovalo court |
| 15 | r | x | x | | | | | | | | | | | x | | | | | Around controller |
| 16 | s | x | x | | | | | | | | | | | x | | | | | Along sidewalk by controller |
| 17 | s | x | x | | | | | | | | | | | x | | | | | Along curb by controller |
| 18 | s | x | x | | | | | | | | | | | x | | | | | Along curb across from controller |
| 19 | s | x | x | | | | | | | | | | | x | | | | | Left of Glorieta |
| 20 | s | x | x | | | | | | | | | | | x | | | | | Left of dosel |
| 21 | r | x | x | | | | | | | | | | | x | | | | | Back of sidewalk across controller |
| 22 | s | x | x | | | | | | | | | | | x | | | | | Right of codo |
| 23 | s | x | x | | | | | | | | | | | x | | | | | Left of lift station |



Duval Landscape

MAINTENANCE

Irrigation Technical Inspection Report

| Irrigation Controller | | | Point of Connection | | | Site Name | SweetWater | | | | | | |
|----------------------------|--------------|---|---------------------|--------------|------|--------------|------------------------|----------|----------|---|----|---|---|
| Location | Right corner | | Location | Right corner | | Location | Rincon dr and ensenada | | | | | | |
| Type | RB | | Size | | | Technician | Preston | | | | | | |
| Rain Guage | Y | N | Source | Meter | Well | Date | 11/21/2024 | | | | | | |
| Power on | Y | N | | | | Program | A | B | C | | | | |
| General Information | | | Backflow | | | Start Times | 10:00 PM | 10:00 PM | 12:00 PM | | | | |
| Valve Type | | | PRV | Y | N | Run times | 6H | 6H | 20M | | | | |
| Coverage | Good | | MV | Y | N | Days of Week | S | M | T | W | Th | F | S |

| Zone | Head Type | Turf | Shrub | Flowers | Lateral Line Break | Zone Not Responding | Low pressure | Zone not Shutting Down | 4" Spray | 6" Spray | 12" Spray | 4" Rotor | Fixed Riser | Cleaned/Replaced Nozzle | Adjusted Spray Pattern | Straightened | Capped | Raised/Lowered | Locations of Zones |
|------|-----------|------|-------|---------|--------------------|---------------------|--------------|------------------------|----------|----------|-----------|----------|-------------|-------------------------|------------------------|--------------|--------|----------------|--------------------|
|------|-----------|------|-------|---------|--------------------|---------------------|--------------|------------------------|----------|----------|-----------|----------|-------------|-------------------------|------------------------|--------------|--------|----------------|--------------------|

| | | | | | | | | | | | | | | | | | | | |
|----|---|---|---|---|--|--|--|---|--|---|--|--|--|---|---|--|--|--|-------------------------------------|
| 1 | s | x | x | | | | | | | | | | | x | | | | | Across from Park right |
| 2 | s | x | x | | | | | | | | | | | x | | | | | Right of rincon |
| 3 | s | x | x | | | | | | | 3 | | | | 3 | x | | | | Around controller |
| 4 | s | x | x | | | | | | | | | | | x | | | | | BTW curb and sidewalk left side |
| 5 | s | x | x | | | | | | | | | | | x | | | | | Right side ensanada 1/2 way |
| 6 | s | x | x | | | | | | | | | | | x | | | | | Right side ensanada 3/4 way |
| 7 | s | x | x | | | | | 1 | | | | | | x | | | | | Right side ensanada end |
| 8 | s | x | x | x | | | | | | | | | | x | | | | | Ensanada/ Rincon right side flowers |
| 9 | s | x | x | x | | | | | | | | | | x | | | | | Ensanada/Rincon Left side flowers |
| 10 | s | x | x | | | | | | | | | | | x | | | | | Rincon 300-248 |
| 11 | s | x | x | | | | | | | | | | | x | | | | | Rincon 238-202 |
| 12 | s | x | x | | | | | | | | | | | x | | | | | Rincon 190*150 |
| 13 | s | x | x | | | | | | | 1 | | | | 1 | x | | | | Rincon 130-88 |
| 14 | s | x | x | | | | | | | | | | | x | | | | | Rincon 78-clock |
| 15 | r | x | x | | | | | | | | | | | x | | | | | Rincon Pond clock-98 |
| 16 | r | x | x | | | | | | | | | | | x | | | | | Rincon pond 108-290 |
| 17 | r | x | x | | | | | | | | | | | x | | | | | Rincon pond to ensanada |
| 18 | r | x | x | | | | | | | | | | | x | | | | | Ensanada Pond at clock |
| 19 | s | x | x | | | | | | | | | | | x | | | | | Ensanada left side at park |
| 20 | s | x | x | | | | | | | | | | | x | | | | | Ensanada left side 1/4 way |
| 21 | s | x | x | | | | | | | | | | | x | | | | | Ensanada left side 1/2 way |
| 22 | s | x | x | | | | | | | | | | | x | | | | | Ensanada left side 3/4 way |
| 23 | s | x | x | | | | | | | | | | | x | | | | | Ensanada left side end |
| 24 | r | x | x | | | | | | | | | | | x | | | | | Park lift station |
| 25 | r | x | x | | | | | 1 | | | | | | x | | | | | Park right side |
| 26 | r | x | x | | | | | | | | | | | x | | | | | Park left side |

| | | | | | | | | | | | | | | | | | | | |
|----|---|---|---|--|--|--|--|--|--|--|---|--|--|--|---|--|--|--|-----------------|
| 27 | s | x | x | | | | | | | | | | | | x | | | | Park beds |
| 28 | s | x | x | | | | | | | | | | | | x | | | | Around park |
| 29 | s | x | x | | | | | | | | 2 | | | | x | | | | Between 78-62 |
| 30 | s | x | x | | | | | | | | | | | | x | | | | Between 228-214 |
| 31 | | | | | | | | | | | | | | | | | | | |

Comments: General maintenance complete 9/16/24



Duval Landscape
MAINTENANCE



Duval Landscape

MAINTENANCE

Irrigation Technical Inspection Report

| Irrigation Controller | | | Point of Connection | | | Site Name | Sweetwater entry | | | | | | |
|-----------------------|------------|---|---------------------|------------|------|--------------|------------------|----------|----------|---|----|---|---|
| Location | Front sign | | Location | Front sign | | Location | Las colinas | | | | | | |
| Type | ICC2 | | Size | 5hp | | Technician | | | | | | | |
| Rain Guage | Y | N | Source | Meter | Well | Date | 11/22/2024 | | | | | | |
| Power on | Y | N | | | | Program | A | B | C | | | | |
| General Information | | | Backflow | | | Start Times | 10:00 PM | 10:00 PM | 12:00 PM | | | | |
| Valve Type | | | PRV | Y | N | Run Times | 5H20M | 5Hrs | 40Mins | | | | |
| Coverage | Good | | MV | Y | N | Days of Week | S | M | T | W | Th | F | S |

| Zone | Head Type | Turf | Shrub | Flowers | Lateral Line Break | Zone Not Responding | Low pressure | Zone not Shutting Down | 4" Spray | 6" Spray | 12" Spray | 4" Rotor | Fixed Riser | Cleaned/Replaced Nozzle | Adjusted Spray Pattern | Straightened | Capped | Raised/Lowered | Locations of Zones |
|------|-----------|------|-------|---------|--------------------|---------------------|--------------|------------------------|----------|----------|-----------|----------|-------------|-------------------------|------------------------|--------------|--------|----------------|----------------------------------|
| 1 | s | x | x | | | | | | | | | | | 1 | x | | | | SW/ Curb at clock |
| 2 | r | x | x | | | | | | | | | | | | x | | | | SW/ Woodline at clock |
| 3 | s | x | x | | | | | | | | | | | | x | | | | Oltero SW/ Curb |
| 4 | r | x | x | | | | | | | | | | | | x | | | | Oltero shrubs SW/ Curb exit side |
| 5 | s | x | x | | | | | | | | | | | | x | | | | Island past guard gate |
| 6 | s | x | x | | | | | | | | | | | | x | | | | Entry island |
| 7 | s | x | x | | | | | | | | | | | | x | | | | Exit side beds outside gate |
| 8 | s | x | x | | | | | | | | | | | | x | | | | Curb S/W Exit side |
| 9 | r | x | x | | | | | | | | | | | | x | | | | Lipizzon both sides |
| 10 | s | x | x | | | | | | | | | | | | x | | | | Left of lipizzon Curb S/W |
| 11 | s | x | x | | | | | | | | | | | | x | | | | Curb S/W Middle exit side |
| 12 | s | x | x | | | | | | | | | | | | | | | | Beds exist side at bend |
| 13 | s | x | x | | | | | | | | | | | | x | | | | S/W End exit side |
| 14 | r | x | x | | | | | | | | | | | | x | | | | Back S/W Both sides at bend |
| 15 | s | x | x | | | | | | | | | | | | x | | | | Curb at bend |
| 16 | s | x | x | | | | | | | | | | | | x | | | | S/W curb middle entry side |
| 17 | r | x | x | | | | | | | | | | | | x | | | | Esmeralda Back S/W Entry |
| 18 | s | x | x | | | | | | | | | | | | x | | | | Esmeralda S/W curb Entry |
| 19 | r | x | x | | | | | | | | | | | | x | | | | Esmeralda Both sides entry |
| 20 | s | x | x | | | | | | | | | | | | x | | | | Lift station |
| 21 | s | x | x | | | | | | | | | | | | x | | | | Esmeralda to lift entry side |
| 22 | s | x | x | | | | | | | | | | | | x | | | | Before gate entry side |
| 23 | s | x | x | | | | | | | | | | | | x | | | | Entry curb |

E.

1.

Sweetwater Creek

Community Development

District

Field Operations Report

12/5/24

Dan Wright
Field Operations Manager
Riverside Management
Services, INC.

Sweetwater
Creek

Community
Development
District

Field Operations
Report

December 5th, 2024

To: The Board of
Supervisors

From: Dan Wright, Field
Operations Manager

RE: Sweetwater Creek
Operations Report -
December 5th, 2024.

The following is a
summary of items related
to the field operations and
maintenance of
Sweetwater Creek CDD.

Completed Projects



La palma park sign
and columns painted

Completed Projects



Street sign replaced at La Palma park

Completed Projects



New swings installed at Ensenada park

Completed Projects



12 new Railroad ties replaced at La Palma park

RMS Operations Report (12/5/24)

In an effort to maintain compliance with the Florida Sunshine Law, please do not reply globally to this notification. Any questions should be directed to the sending party only or to the District Office at (904) 940-5850

- Painted La Palma park sign/columns
- Fixed fountain in front of fitness
- New street sign hung
- Roundabout pressure washed
- 2 swings at Ensenada park replaced
- 12 new railroad ties replaced surrounding La Palma park mulch
- Speed sign locations changed
- Mirror installed in fitness center lobby
- Lights surrounding pool replaced
- Pool furniture/garbage cans pressure washed
- Water fountain at ensenada park fixed
- Gate latch at Ensenada park replaced
- Christmas decorations hung throughout community
- Playground pieces ordered for Ensenada park

Conclusion

For any questions or comments regarding the above information or for any future maintenance requests and concerns please contact:

dwright@rmsnf.com

jlambert@rmsnf.com

Respectfully,

Riverside Management Services



2.

ESTIMATE



Prepared For

Daniel
(845) 544-3290

2 Men Concrete

11001 old Saint Augustine Rd, Apartment 2110
Jacksonville, Florida 32257
Phone: (904) 404-6889
Email: 2menconcretejax@gmail.com

Estimate # 868
Date 11/07/2024

Description

Concrete repair

Remove old concrete, level and prep area, pour new concrete (2" Concrete base, 4" concrete Slab, +3500PSI), broom finish and clean.

Measurements:

7 small repair \$200 each
2 Repair sevil \$400 each
2 Concrete pad \$500 each
1 Grand \$100

Warranty Concrete

1-year guarantee for concrete services, this guarantee can be used for any trace of stain, crack or anything that shows that the quality and durability of the work has been affected. The date begins after the last receipt of the final payment that must be collected at the end of the service.

Total Prices

The total price includes tax, materials, labor and transportation of disposals.

The deposit is collected when the job is already started, 50% and the rest when is finish.

Insurances and licenses from the company is attached with this document you will find scrolling down the estimate.

| | |
|-----------------|------------|
| Subtotal | \$3,300.00 |
|-----------------|------------|

| | |
|--------------|-------------------|
| Total | \$3,300.00 |
|--------------|-------------------|

| | |
|--------------------|-------------------|
| Deposit Due | \$1,650.00 |
|--------------------|-------------------|

By signing this document, the customer agrees to the services and conditions outlined in this document.

Daniel



All American Concrete Florida

904-478-1933 | sales@allamericanconcretefl.com |
allamericanconcretejacksonville.com

RECIPIENT:

Sweetwater Creek CDD

1187 Las Calinas Boulevard
St. Augustine, Florida 32095

Quote #255

Sent on

Nov 19, 2024

Total

\$9,500.00

| Product/Service | Description | Qty. | Unit Price | Total |
|------------------------|---|------|------------|------------|
| Concrete Repairs | <p>We will be conducting repairs on multiple sections of a nature walk with the following specifications: 4'x3', 4'x3', 4'x3', 5'x1', 5'x2', 8'x3', 8'x3', 9'x6', 5'x5', 7'x5', 10'x5'.</p> <p>Our process includes the precise cutting out of the damaged areas using a diamond blade concrete saw. All debris will be meticulously removed and loaded into a dumpster for proper offsite disposal. We will ensure meticulous framing for exact replacement sizes and utilize laser leveling where necessary to achieve precise adherence and proper surface water shed.</p> <p>For the installation, we will be using 3000psi concrete with fiber additive, ensuring a mix of 57/87 with no recycled aggregate. Additionally, all expansion joints will be installed at the time of concrete installation to guarantee a high-quality finish.</p> | 1 | \$9,500.00 | \$9,500.00 |
| All American Advantage | We offer a 10-year warranty that covers any cracks matching the width and depth of a quarter resulting from our workmanship. | 1 | \$0.00 | \$0.00 |

Total

\$9,500.00

This quote is valid for the next 30 days, after which values may be subject to change.

Signature: _____

Date: _____



1702 Lindsey Rd
Jacksonville, Fl. 32221
Ph (904) 781-7060 Fax (904) 619-5011

CGC1523954 CMC1250093 CFC1428601 CCC1329086

Sweetwater at Palencia

Attn: Dan Wright -RMSNF
11 5 24
Re;concrete /asphalt repairs

All Weather Contractors is proposing the following services for the below mentioned prices. Any item not specifically mentioned is subject to a written change order.

>saw cut and remove up to a total of 167 sq ft of asphalt in 8 locations on the bike path per management
>install new limerock and needed and compact and install approx. 2'' of type 2 hot mix asphalt and compact level with the existing asphalt

>saw cut and remove up to a total of 72 sq ft in 5 locations of concrete sidewalks at Ensanada Park at the entry /exit sidewalks
>saw cut and remove any tree roots where the concrete was removed
>form and pour up to 72 sq ft of 4'' thick 3000 psi concrete with a light broom finish
>clean up job and haul away debris

Total Price \$4,985.00

Proposal Signed by _____ **Printed Name** _____

Thank you for your consideration

Scott Haines -C 904.402.6561

F.

1.

From: egunia@rmsnf.com 
Subject: November Ops Report
Date: November 26, 2024 at 4:57 PM
To: Courtney Hogge chogge@gmsnf.com



Pool:

Estimate for replacement of starting blocks. One estimate attached. I advise to not replace all eight. I think that we should consider replacing only six, four or even two.

Fence Replaced: We are still waiting for the smash bar materials to be sent for the gate between the Pickleball Courts and Pool. The invoice has not been paid.

Gym Equipment:

Bids for replacement of 90% of strength equipment.
Echelon bike replaced.

Building:

Front of roof pressure washed
Decorations for facility, Pickleball courts and parks were purchased and placed.
Estimate for closet construction in hallway. This would be used for storage of the tables, chairs and other items that need to be in a climatized environment as well as more accessible to staff.

Parks:

Rendering for new landscaping around the putt putt course attached. Waiting for cost estimate. The current area amongst the holes has vegetation but should not be described as landscaping.
Putt-Putt turf estimates stalled. I am still pursuing more options.

Pickleball:

Intermediate League is doing extremely well. Full participation. A tournament and holiday party are planned for December 11th.
Court Reserve Accounts: 660

Community:

Plans to work with Marshall Creek CDD for movie nights and possible other events are coming together. The area between Vale and Glorietta is a prime location for both neighborhoods. Dan Colin put together a proposal to show its potential use.
Fitness Challenge: Planksgiving

Staff: Training on de-escalation of resident arguments, watching shoe apparel and cleaning.

Shade Structures: Still waiting for additional estimates. I had a new company out the other week and am waiting for their communication.

Erin Gunia
Director of Amenities
Sweetwater Creek CDD
904-829-8488
egunia@rmsnf.com

2.



TRUST — *the* — EXPERTS

For over a decade, our customers have entrusted us to provide safe and affordable playground and recreational equipment. Our team of Certified General Contractors and Playground Safety Inspectors will insure that your project is completed to perfection, providing truly turnkey service, with every step of the process from planning and budgeting, through the installation being handled under one roof.



1-800-573-7529 | www.proplaygrounds.com



Pro Playgrounds
8490 Cabin Hill Road
Tallahassee, FL 32311

Quote

| | |
|-------------|-------------------|
| Date | Estimate # |
| 10/22/2024 | 35520 |

| |
|---------------------------|
| Project Name |
| Marshall Creek CDD Shades |



| |
|---|
| Customer / Bill To |
| Marshall Creek CDD Erin Gunia 1865 North Loop Pkwy St. Augustine, FL 32095 |

| |
|---|
| Ship To |
| Marshall Creek CDD Erin Gunia 1865 North Loop Pkwy St. Augustine, FL 32095 |



WE WILL BEAT ANY PRICE BY 5%!

| Item | Description | Qty | Cost | Total: |
|----------|--|-----|-----------|-----------|
| | Furnish labor and materials to: 1. Install various shades at specific locations 2. provide eng dwgs 3. permitting | | | |
| | **SHADE | | | |
| | STRUCTURES** | | | |
| | AREA 1 (N. Loop Pkwy) | | | |
| CSSD | Kite Shades, approx 30x30 with single column higher | 2 | 9,800.00 | 19,600.00 |
| ENGDRAW | Engineered Drawings for Permitting | 1 | 840.00 | 840.00 |
| Shipping | Combined Shipping and Freight Charges | 1 | 2,095.20 | 2,095.20 |
| LBR | Labor and Installation, rentals, concrete, rebar, etc | 1 | 15,000.00 | 15,000.00 |
| | AREA 2 (Bocci courts) | | | |
| CSSD | Custom Shade Design Hanging Cantilever, 40x14x8, two sided | 1 | 16,100.00 | 16,100.00 |
| | OR | | | |
| CSSD | Custom Shade Design 30x15x8 Hip, 4 columns | 1 | 6,328.00 | 6,328.00 |
| ENGDRAW | Engineered Drawings for Permitting | 1 | 840.00 | 840.00 |
| Shipping | Combined Shipping and Freight Charges | 1 | 1,920.00 | 1,920.00 |
| LBR | Labor and Installation, rentals, concrete, rebar, etc | 1 | 15,000.00 | 15,000.00 |

AGREED AND ACCEPTED:
If the above total price, scope of work, specifications, terms and conditions are acceptable, sign below indicating your acceptance and authorization for Pro Playgrounds to proceed with the work and/or sales transaction described in this quotation. Upon signature and payment in accordance with this quote, Pro Playgrounds will proceed with the work and/or sales transaction.

_____/_____/_____
Signature Name / Title Date

| |
|--------------------------|
| Subtotal: |
| Sales Tax: (7.5%) |
| Total: |

Terms and Conditions - Price valid for 30 days and subject to change. 1. If installation is not included with your purchase, client will be responsible for coordinating, receiving and unloading of all goods, delivery drivers will not help unload goods. 2. Client will be responsible to inspect goods for defect, damage or missing parts, any deficiency or missing parts must be noted on delivery slip. 3. Client will be responsible for costs due to cancelled or missed delivery appointments. 4. Client has reviewed all items, colors and descriptions on this quote for accuracy and correctness. 5. If quote includes installation of goods, the installation is subject to the terms and conditions of Pro Playgrounds "Standard Installation Agreement" a copy of which may be obtained from your Sales Representative.



Pro Playgrounds
 8490 Cabin Hill Road
 Tallahassee, FL 32311

Quote

| | |
|-------------|-------------------|
| Date | Estimate # |
| 10/22/2024 | 35520 |

| |
|---------------------------|
| Project Name |
| Marshall Creek CDD Shades |



| |
|---|
| Customer / Bill To |
| Marshall Creek CDD Erin Gunia 1865 North Loop Pkwy St. Augustine, FL 32095 |

| |
|---|
| Ship To |
| Marshall Creek CDD Erin Gunia 1865 North Loop Pkwy St. Augustine, FL 32095 |



WE WILL BEAT ANY PRICE BY 5%!

| Item | Description | Qty | Cost | Total: |
|----------|---|-----|-----------|-----------|
| | AREA 3 (playground) | | | |
| CSSD | Hip Shade, over existing playground, 24x28x12 SG | 1 | 10,792.60 | 10,792.60 |
| ENGDRAW | Engineered Drawings for Permitting | 1 | 840.00 | 840.00 |
| Shipping | Combined Shipping and Freight Charges | 1 | 1,320.00 | 1,320.00 |
| LBR | Labor and Installation, rentals, concrete, rebar, etc | 1 | 13,500.00 | 13,500.00 |
| | AREA 4 (playground and picnic space) | | | |
| CSSD | Hip shade 28x42x12 SN over existing equipment | 1 | 15,831.20 | 15,831.20 |
| | AND | | | |
| CSSD | HC 18x12x8 cantilever over the picnic area | 1 | 7,187.60 | 7,187.60 |
| ENGDRAW | Engineered Drawings for Permitting | 2 | 840.00 | 1,680.00 |
| Shipping | Combined Shipping and Freight Charges | 1 | 2,160.00 | 2,160.00 |
| LBR | Labor and Installation, rentals, concrete, rebar, etc | 1 | 18,000.00 | 18,000.00 |
| | **PERMITTING** | | | |

AGREED AND ACCEPTED:
 If the above total price, scope of work, specifications, terms and conditions are acceptable, sign below indicating your acceptance and authorization for Pro Playgrounds to proceed with the work and/or sales transaction described in this quotation. Upon signature and payment in accordance with this quote, Pro Playgrounds will proceed with the work and/or sales transaction.

_____/_____/_____
 Signature Name / Title Date

| |
|--------------------------|
| Subtotal: |
| Sales Tax: (7.5%) |
| Total: |

Terms and Conditions - Price valid for 30 days and subject to change. 1. If installation is not included with your purchase, client will be responsible for coordinating, receiving and unloading of all goods, delivery drivers will not help unload goods. 2. Client will be responsible to inspect goods for defect, damage or missing parts, any deficiency or missing parts must be noted on delivery slip. 3. Client will be responsible for costs due to cancelled or missed delivery appointments. 4. Client has reviewed all items, colors and descriptions on this quote for accuracy and correctness. 5. If quote includes installation of goods, the installation is subject to the terms and conditions of Pro Playgrounds "Standard Installation Agreement" a copy of which may be obtained from your Sales Representative.



Pro Playgrounds
8490 Cabin Hill Road
Tallahassee, FL 32311

Quote

| |
|---------------------------|
| Project Name |
| Marshall Creek CDD Shades |



| | |
|-------------|-------------------|
| Date | Estimate # |
| 10/22/2024 | 35520 |

| |
|---|
| Customer / Bill To |
| Marshall Creek CDD Erin Gunia 1865 North Loop Pkwy St. Augustine, FL 32095 |

| |
|---|
| Ship To |
| Marshall Creek CDD Erin Gunia 1865 North Loop Pkwy St. Augustine, FL 32095 |



WE WILL BEAT ANY PRICE BY 5%!

| Item | Description | Qty | Cost | Total: |
|----------|--|-----|-------------|-------------|
| ISPERMIT | Note: Each different design will require a separate permit through the Building dept. Site plans and eng dwgs are required and will be created. Project Managers in our main office manage this step in the process. Total cost of permitting may vary based on number of Shades. PERMIT - STATE OF FLORIDA - APPLICATION THRU FINAL INSPECTION< COST SHALL BE \$2000 OR 5% OF TOTAL PROJECT COST, WHICHEVER IS GREATER. PRICE DOES NOT INCLUDE COST OF ENGINEERING OR SEALED DRAWINGS. | 1 | 2,000.00 | 2,000.00 |
| DSC | Note: existing site prep by owner Discount | 1 | -151,034.60 | -151,034.60 |

AGREED AND ACCEPTED:
If the above total price, scope of work, specifications, terms and conditions are acceptable, sign below indicating your acceptance and authorization for Pro Playgrounds to proceed with the work and/or sales transaction described in this quotation. Upon signature and payment in accordance with this quote, Pro Playgrounds will proceed with the work and/or sales transaction.

_____/_____/_____
Signature Name / Title Date

| | |
|--------------------------|---------------|
| Subtotal: | \$0.00 |
| Sales Tax: (7.5%) | \$0.00 |
| Total: | <u>\$0.00</u> |

Terms and Conditions - Price valid for 30 days and subject to change. 1. If installation is not included with your purchase, client will be responsible for coordinating, receiving and unloading of all goods, delivery drivers will not help unload goods. 2. Client will be responsible to inspect goods for defect, damage or missing parts, any deficiency or missing parts must be noted on delivery slip. 3. Client will be responsible for costs due to cancelled or missed delivery appointments. 4. Client has reviewed all items, colors and descriptions on this quote for accuracy and correctness. 5. If quote includes installation of goods, the installation is subject to the terms and conditions of Pro Playgrounds "Standard Installation Agreement" a copy of which may be obtained from your Sales Representative.



Kite Hip Sail

great flexibility

- Popular choice for pools, splash pads, and dining areas
- Kite-shaped design allows for great flexibility and many configurations
- Great for covering uniquely shaped spaces
- Features three columns at equal entry height, with the fourth being a diagonal elevated column
- Must be designed in a square size

SIZES

10'-25' Square

OPTIONS, FEATURES, AND FABRIC

Surface or In-Ground Mount

8', 10', or 12' Height, Custom Heights Available

With or Without Glide Elbow™

Multi-Dome Hanging Cantilever Hip Shade

| | | | | | |
|----------------------|-------------|----------------------|---------------|---------------------|---------------|
| Length | 20' | Width | 14' | Entry Height | 8' |
| Peak Height | 10.83' | Elbow | Standard | Column Mount | Base Plate |
| Column Size | 10"x6"x1/4" | Rafter Size | Ø2.875" 12-Ga | Ridge Size | Ø2.875" 12-Ga |
| Column Length | 9.5' | Rafter Length | 9.95' | Ridge Length | 7.03' |
| Dome Qty. | 2 | Column Qty. | 0 | Beam Size | 6"x4"x1/4" |

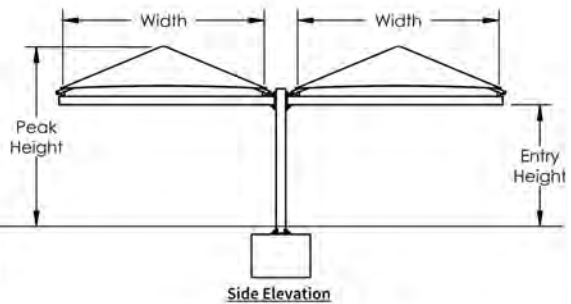
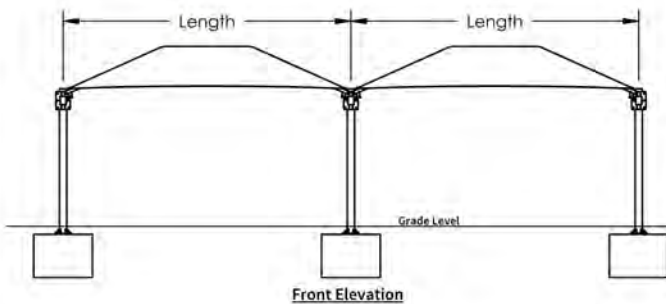
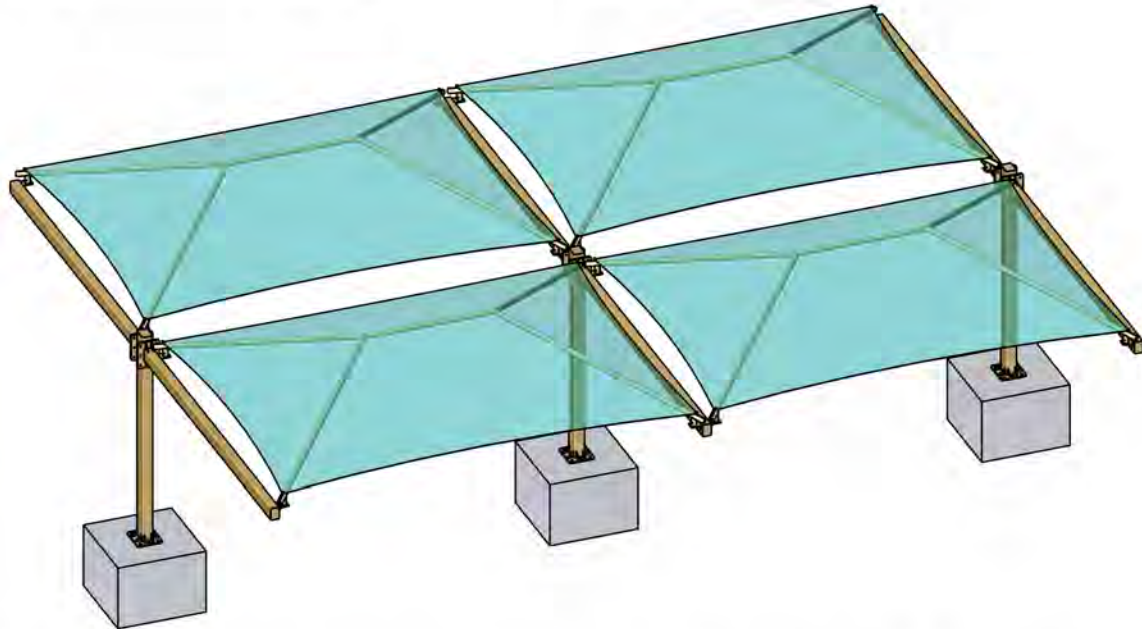

| Square Footing | | |
|----------------|----------------|-------|
| Column | Length & Width | Depth |
| Single Cap | 3.42 | 3 |
| Double Cap | 3.762 | 3 |

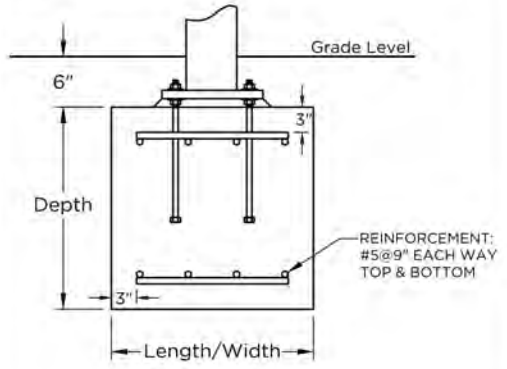

| Auger Footing | | |
|---------------|------------------|------------------|
| Diameter | Single Cap Depth | Double Cap Depth |
| 1'-6" | | |
| 2'-0" | Out of range | Out of range |
| 2'-6" | 5.71 | Out of range |
| 3'-0" | 3.96 | 4.81 |

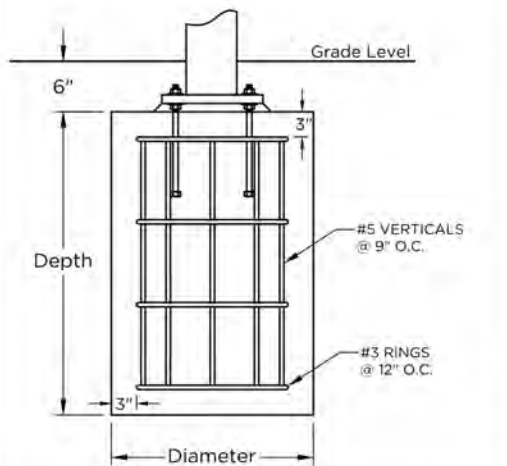

SuperiorShade

QUOTE
89664

SHADE SIZE
20 X 14

SHADE STYLE
Multi-Dome Hanging
Cantilever Hip Shade

These drawings are for reference only and should not be used as construction details. They show the general character and rough dimensions of the structural features. Exact spans, fasteners, materials, and foundations can be determined by a licensed professional engineer upon request. Estimated footing size above is based on 1,500 PSF soil bearing pressure.

Hip Shade

| | | | | | |
|----------------------|-------------|----------------------|-------------|---------------------|-------------|
| Length | 30' | Width | 15' | Entry Height | 8' |
| Peak Height | 11.03' | Elbow | Standard | Column Mount | Base Plate |
| Column Size | Ø5.0" 11-Ga | Rafter Size | Ø3.5" 11-Ga | Ridge Size | Ø3.5" 11-Ga |
| Column Length | 8.5' | Rafter Length | 10.66' | Ridge Length | 16.1' |
| Dome Qty. | 1 | Column Qty. | 4 | | |

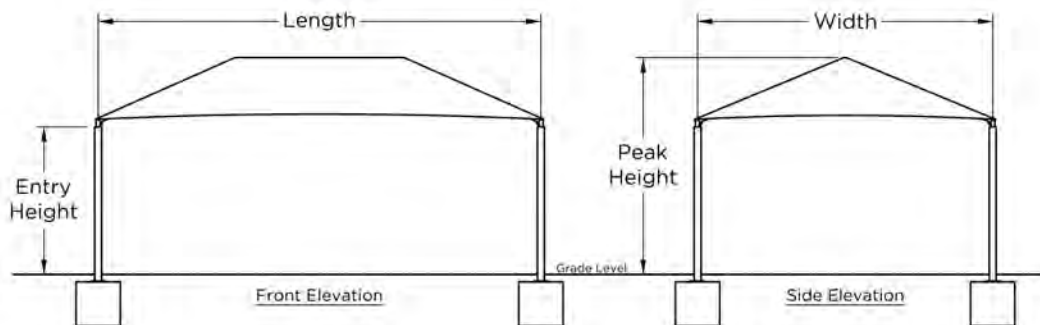
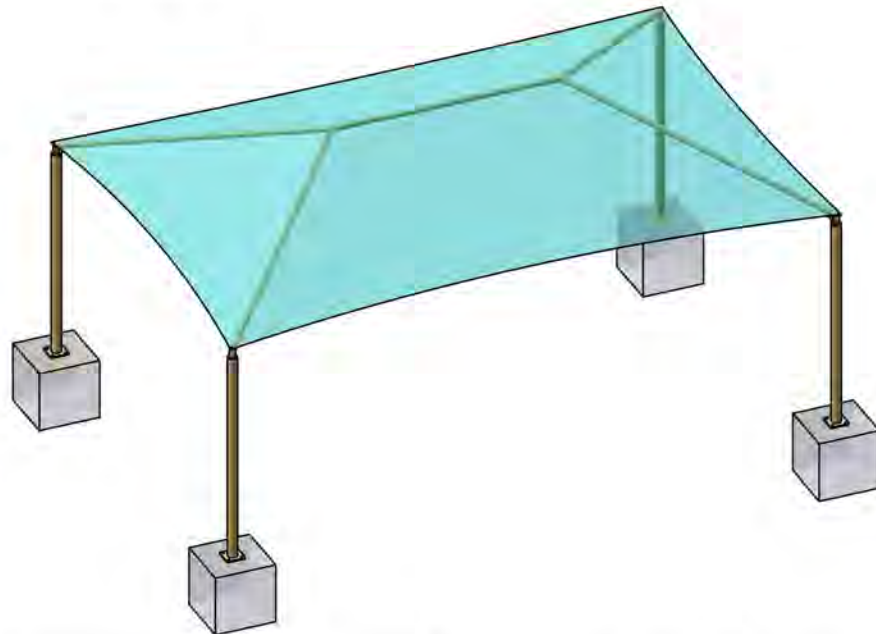

| Square Footing | | |
|----------------|----------------|-------|
| Column | Length & Width | Depth |
| Single Cap | 2.69 | 3 |
| Double Cap | N/A | 3 |

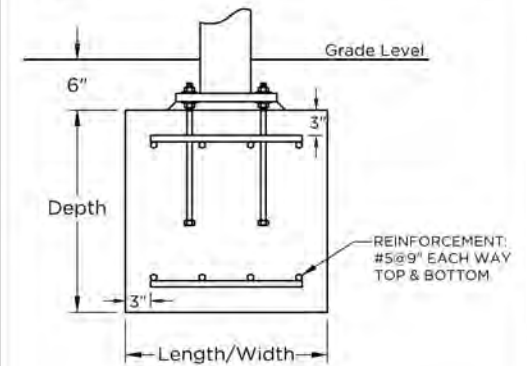

| Auger Footing | | |
|---------------|------------------|------------------|
| Diameter | Single Cap Depth | Double Cap Depth |
| 1'-6" | | |
| 2'-0" | Out of range | N/A |
| 2'-6" | 3.53 | N/A |
| 3'-0" | Out of range | N/A |

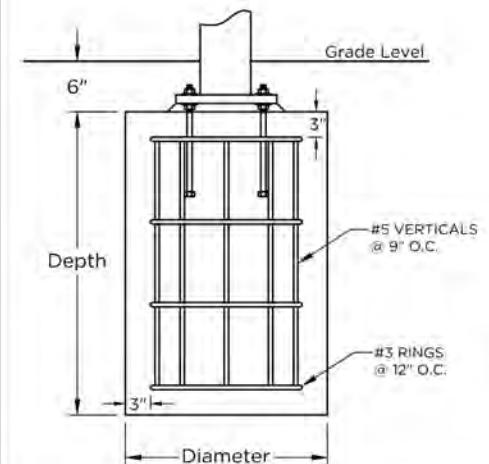

SuperiorShade

QUOTE

89664

SHADE SIZE

30 X 15

SHADE STYLE

Hip Shade

These drawings are for reference only and should not be used as construction details. They show the general character and rough dimensions of the structural features. Exact spans, fasteners, materials, and foundations can be determined by a licensed professional engineer upon request. Estimated footing size above is based on 1,500 PSF soil bearing pressure.



Standard Hip

most versatile shade solution

- Most versatile and economical shade
- Great solution for schools, parks, and churches

Should the length to width ratio require it, we may design a Multi-Dome to ensure uniform tension throughout your canopy.

SHAPES AND SIZES



Square

Available in
2' Increments
from 10'-60'



Rectangle

Available in
Over 25 Sizes



Hexagon

Available in
2' Increments
from 20'-40'

Hip Shade

| | | | | | |
|----------------------|--------------|----------------------|-------------|---------------------|-------------|
| Length | 28' | Width | 24' | Entry Height | 12' |
| Peak Height | 16.44' | Elbow | Glide | Column Mount | Base Plate |
| Column Size | Ø6.6" Sch-40 | Rafter Size | Ø3.5" 11-Ga | Ridge Size | Ø3.5" 11-Ga |
| Column Length | 12.5' | Rafter Length | 15.64' | Ridge Length | 10' |
| Dome Qty. | 1 | Column Qty. | 4 | | |

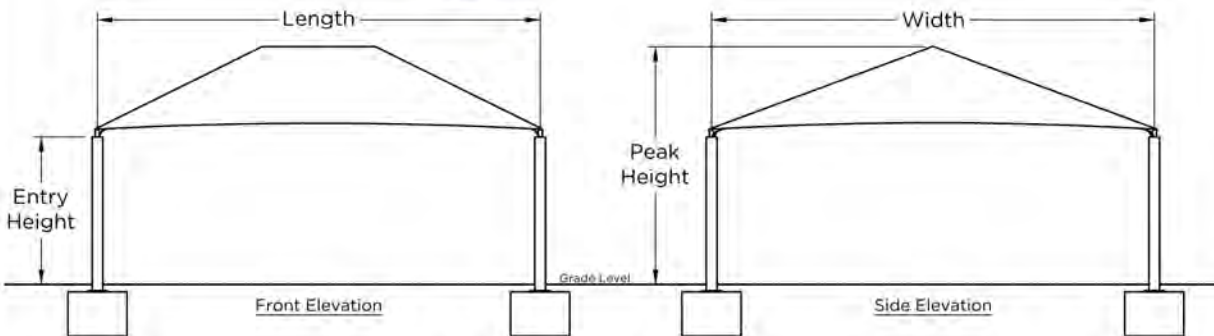
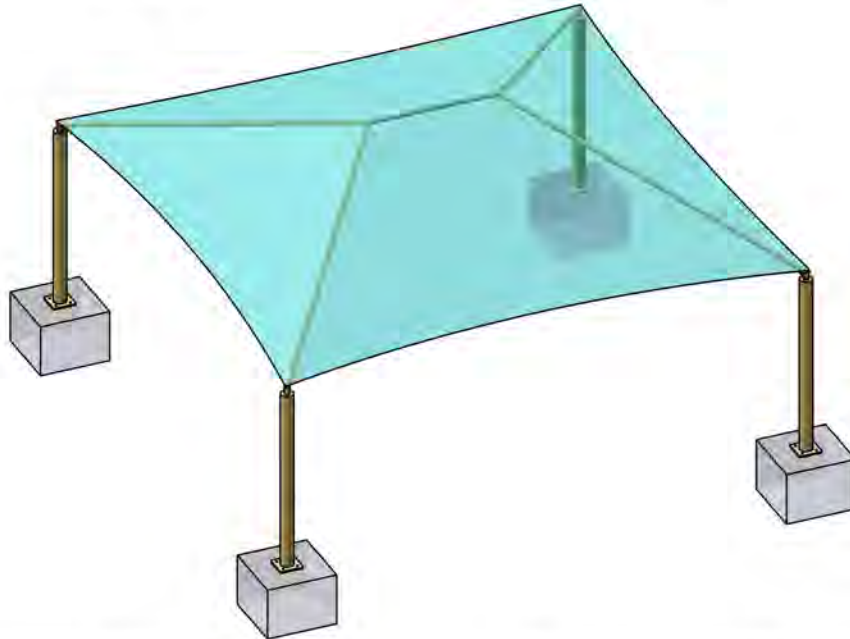

| Square Footing | | |
|----------------|----------------|-------|
| Column | Length & Width | Depth |
| Single Cap | 3.62 | 3 |
| Double Cap | N/A | 3 |

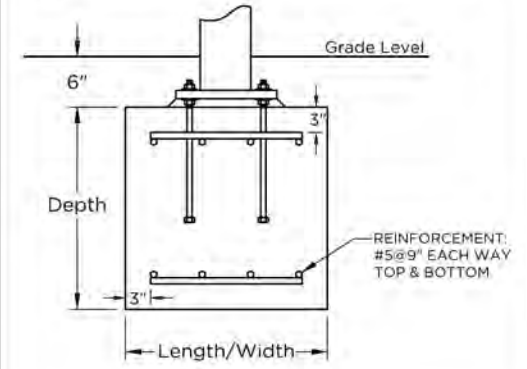

| Auger Footing | | |
|---------------|------------------|------------------|
| Diameter | Single Cap Depth | Double Cap Depth |
| 1'-6" | | |
| 2'-0" | Out of range | N/A |
| 2'-6" | Out of range | N/A |
| 3'-0" | 4.44 | N/A |

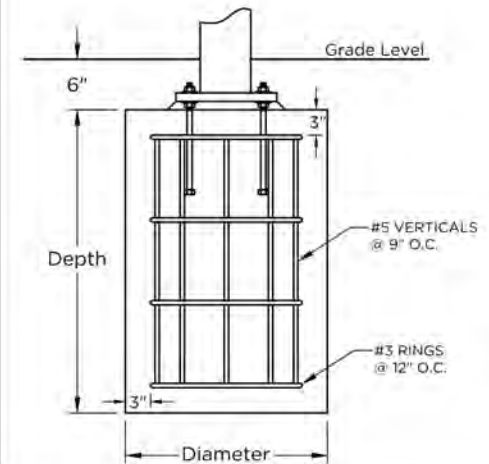

SuperiorShade

QUOTE
89664

SHADE SIZE
28 X 24

SHADE STYLE
Hip Shade

These drawings are for reference only and should not be used as construction details. They show the general character and rough dimensions of the structural features. Exact spans, fasteners, materials, and foundations can be determined by a licensed professional engineer upon request. Estimated footing size above is based on 1,500 PSF soil bearing pressure.

Hip Shade

| | | | | | |
|----------------------|--------------|----------------------|------------|---------------------|------------|
| Length | 42' | Width | 28' | Entry Height | 12' |
| Peak Height | 17.65' | Elbow | Standard | Column Mount | Base Plate |
| Column Size | Ø8.6" Sch-40 | Rafter Size | Ø5.0" 7-Ga | Ridge Size | Ø5.0" 7-Ga |
| Column Length | 12.5' | Rafter Length | 19.91' | Ridge Length | 16.06' |
| Dome Qty. | 1 | Column Qty. | 4 | | |

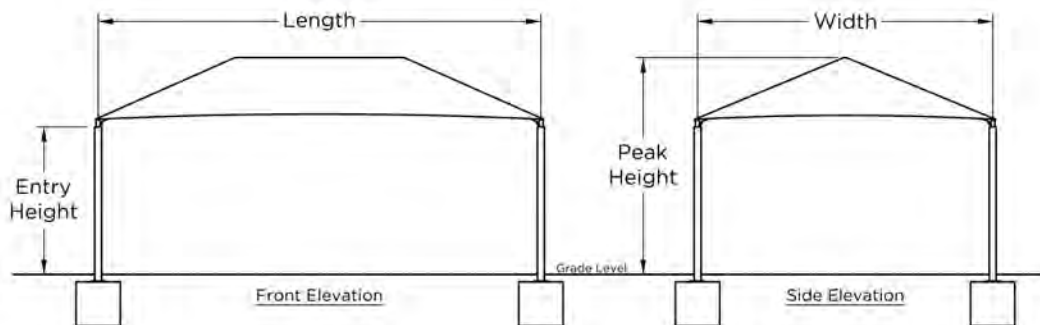
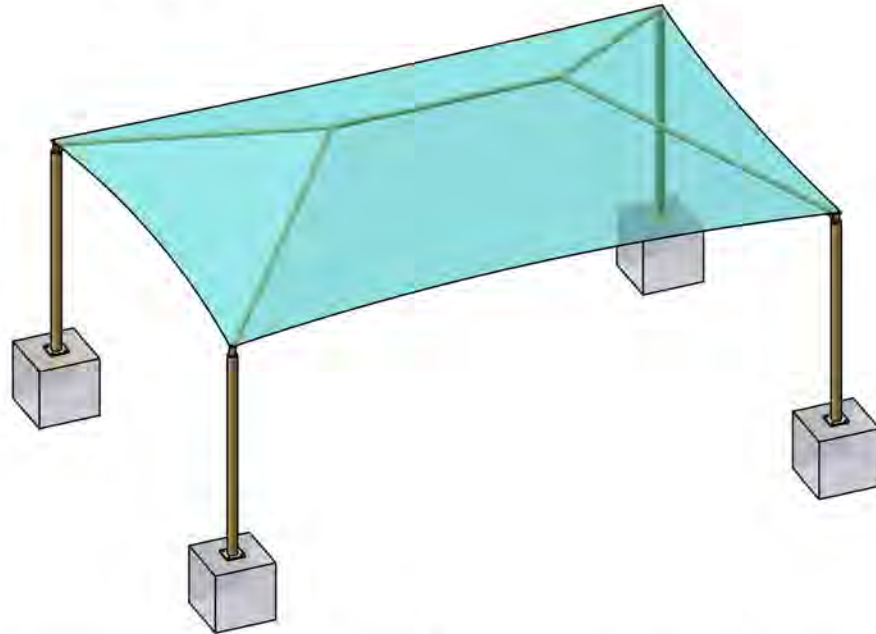

| Square Footing | | |
|----------------|----------------|-------|
| Column | Length & Width | Depth |
| Single Cap | 4.78 | 3 |
| Double Cap | N/A | 3 |

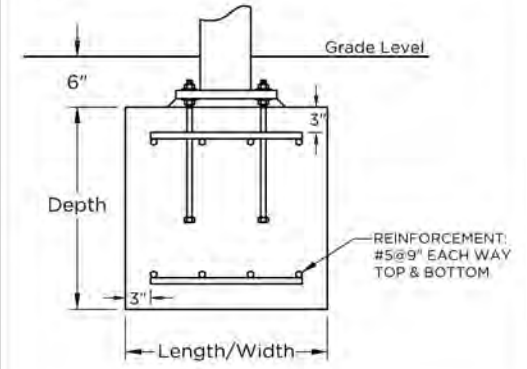

| Auger Footing | | |
|---------------|------------------|------------------|
| Diameter | Single Cap Depth | Double Cap Depth |
| 1'-6" | | |
| 2'-0" | Out of range | N/A |
| 2'-6" | Out of range | N/A |
| 3'-0" | 7.77 | N/A |

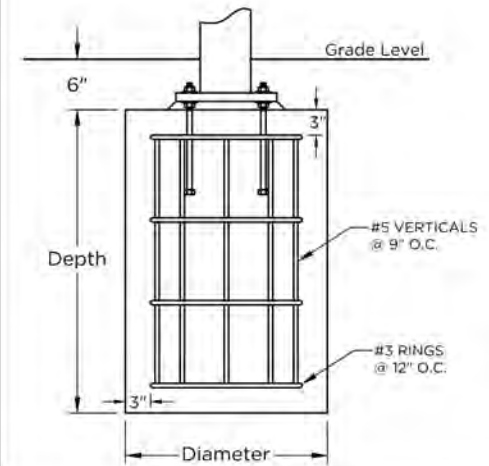

SuperiorShade

QUOTE

89664

SHADE SIZE

42 X 28

SHADE STYLE

Hip Shade

These drawings are for reference only and should not be used as construction details. They show the general character and rough dimensions of the structural features. Exact spans, fasteners, materials, and foundations can be determined by a licensed professional engineer upon request. Estimated footing size above is based on 1,500 PSF soil bearing pressure.



Hanging Cantilever

cover any distance



360°
View in 360°
& choose colors!

- Great solution for walkways, bus stop seating, and bleachers
- Has a preferred max width of 18' but can be configured with multiple bays to cover any distance
- While standard sizes are available with 8' heights, it can be custom made for your location

Hanging Cantilever Hip Shade

| | | | | | |
|----------------------|------------|----------------------|-------------|---------------------|-------------|
| Length | 18' | Width | 12' | Entry Height | 8' |
| Peak Height | 10.42' | Elbow | Standard | Column Mount | Base Plate |
| Column Size | 7"x5"x1/4" | Rafter Size | Ø2.5" 12-Ga | Ridge Size | Ø2.5" 12-Ga |
| Column Length | 9.5' | Rafter Length | 8.53' | Ridge Length | 6.88' |
| Dome Qty. | 1 | Column Qty. | 2 | Beam Size | 6"x4"x3/16" |

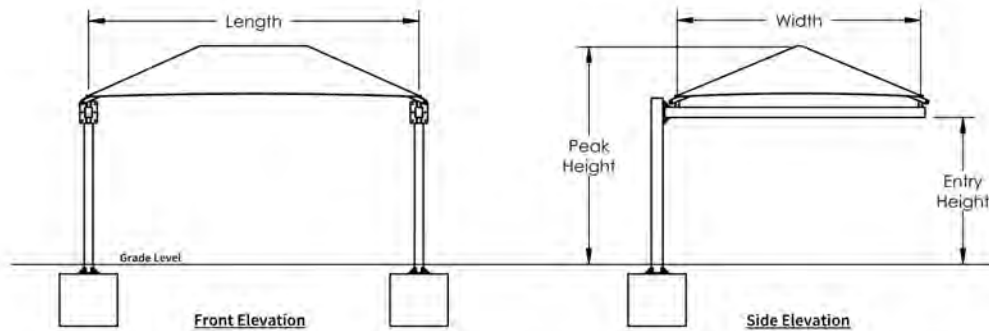
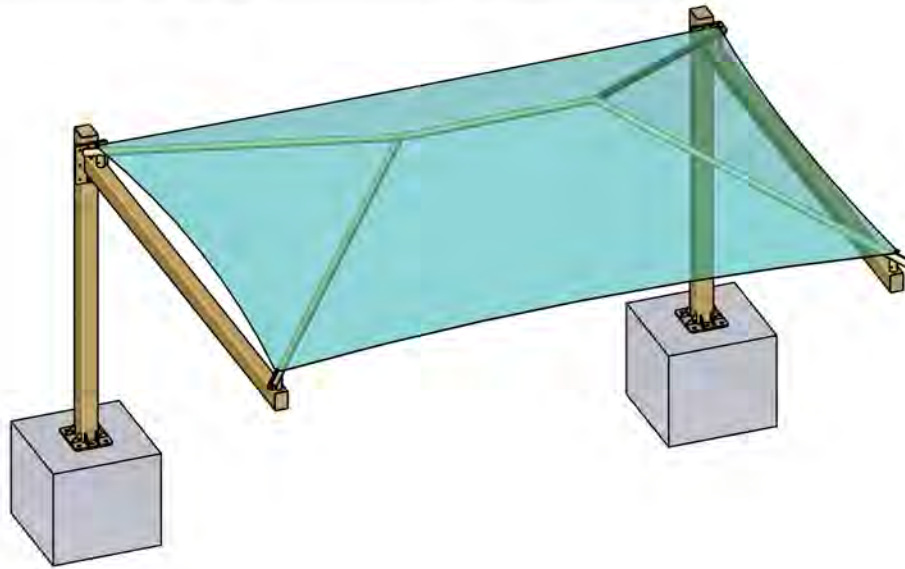

| Square Footing | | |
|----------------|----------------|-------|
| Column | Length & Width | Depth |
| Single Cap | 3 | 3 |
| Double Cap | N/A | 3 |

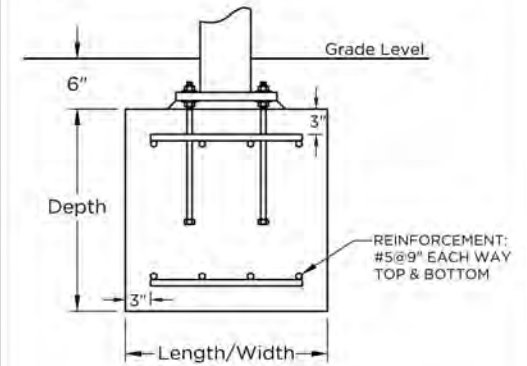

| Auger Footing | | |
|---------------|------------------|------------------|
| Diameter | Single Cap Depth | Double Cap Depth |
| 1'-6" | | |
| 2'-0" | Out of range | N/A |
| 2'-6" | 4.4 | N/A |
| 3'-0" | 3.06 | N/A |

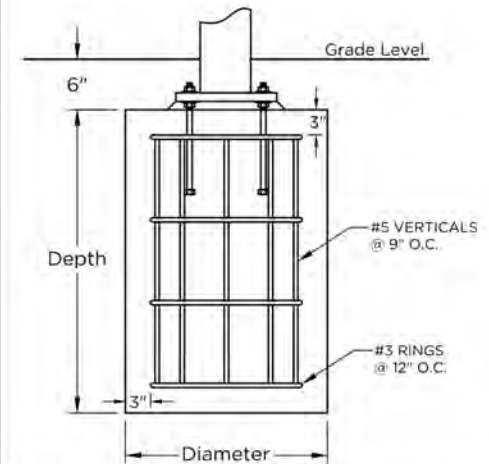

SuperiorShade

QUOTE

89664

SHADE SIZE

18 X 12

SHADE STYLE

**Hanging Cantilever
Hip Shade**

These drawings are for reference only and should not be used as construction details. They show the general character and rough dimensions of the structural features. Exact spans, fasteners, materials, and foundations can be determined by a licensed professional engineer upon request. Estimated footing size above is based on 1,500 PSF soil bearing pressure.

Color Options

Frames

Backed by a [5-year limited warranty](#).

Gloss

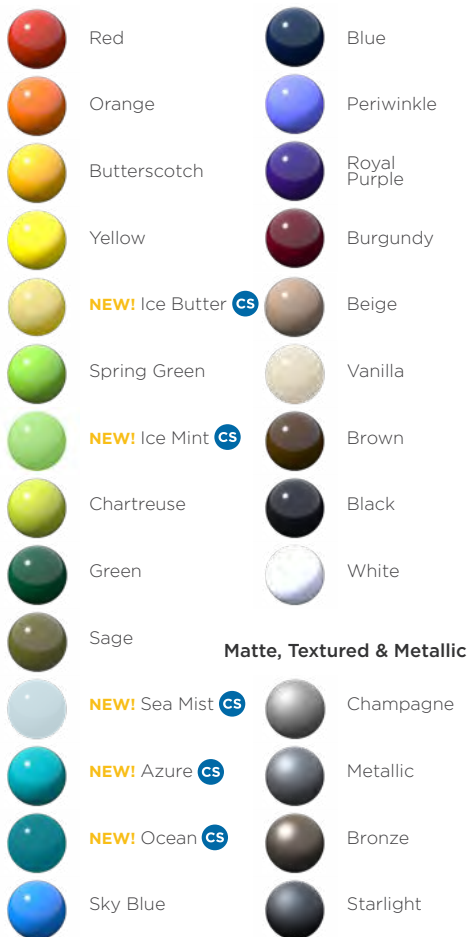

Waterproof Shade Fabric

For our Arched Cantilever, Flower, and Single Post and Cantilever Waterproof Umbrellas. Backed by a [10-year limited warranty](#).



Traditional Fabric

This selection of fabric options includes colors that are California Fire Marshal certified and pass the NFPA 701 or ASTM E84 tests. Select color options are noted as flame retardant. Backed by a [10-year limited warranty](#).

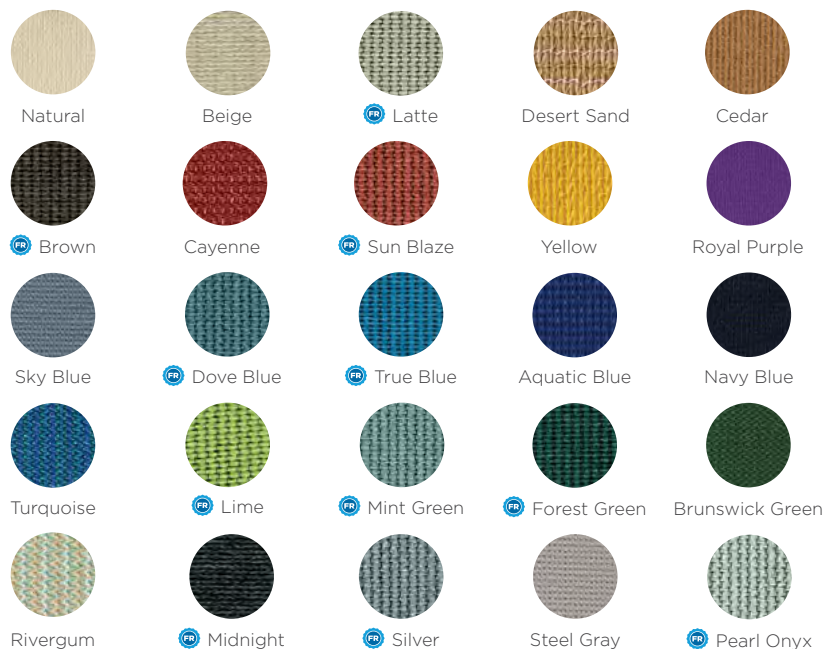

Dual Shade Fabric

Available for an upcharge for our Hypar Umbrella, Triangle Sail, and Hyperbolic Sail. Backed by a [10-year limited warranty](#).

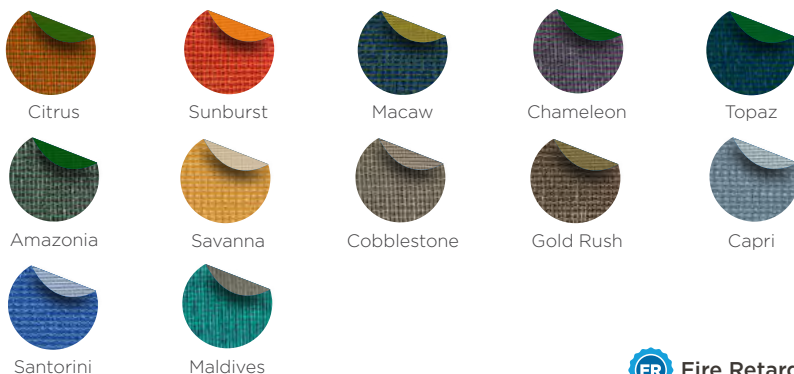

CS Color Coming Soon! Ask your representative about availability.

Complete Your Space

When combined, Superior Recreational Products' product lines create complete site environments. Design your space using one superior company.

Visit srpshade.com, srpplayground.com, and srpsiteamenities.com to learn more.



Material Specifications, Warranty, and Policies

Material Specifications

Fabric

- Shade fabric is made of UV stabilized cloth manufactured by Alnet Americas or approved equal
- The high density polyethylene material shall be manufactured with tensioned fabric structures in mind
- The fabric knit is to be made using monofilament and tape filler which has a weight of 9.38 to 10.32 oz. sq. yd. Material to be Rachel-knitted to ensure material will not unravel if cut
- Cloth meets fire resistance tests as follows:

Alnet Americas Extra Block: California State Fire Marshall Reg. #F-93501

Others: NFPA 701-99 (Test Method 2) and ASTM E-84

Fabric Properties

| | |
|-------------------------|--|
| Stretch | Stentored |
| Tear Tests (lbs/ft) | WARP 44.8 WEFT 44 |
| Burst Tests (lbs ft) | 828 lbf (ASTM 3786) |
| Fabric Weight (oz/sqFT) | Avg 1.02 to 1.07 oz. |
| Fabric Width | 9' 10" |
| Roll Length | 150' |
| Roll Size | 63" x 16 ½" |
| Weight | 120 lbs. |
| Life Expectancy | 10 Years |
| Fading | Minimum Fading After 6 years, 3 Years for Red and Yellow |
| Min. Temperature | -77° |
| Max. Temperature | +167° |

Shade Protection and UV Screen Protection Factors

| Color | Shade Cover | UVR Block Out |
|----------------|-------------|---------------|
| True Blue | 93% | 89% |
| Beige | 97% | 87% |
| Forest Green | 96% | 94% |
| Sun Blaze | 94% | 91% |
| Silver | 95% | 93% |
| Rivergum Green | 88.7% | 92.9% |
| Sky Blue | 89% | 92.2% |
| Navy Blue | 93.6% | 94.4% |
| Turquoise | 86% | 91.5% |
| Yellow | 77.6% | 95.5% |

To view a complete list of fabrics, please reference the Color Options page of our catalog by clicking [here](#).

Thread

- Shall be 100% expanded PTFE fiber that is high strength and low shrinkage
- Shall have a wide temperature and humidity range
- Abrasion resistant and UV radiation immunity
- Shall be unaffected by non-hydrocarbon based cleaning agents, acid rain, mildew, chlorine, saltwater, and pollution
- Lockstitch thread - 1200 Denier or equal
- Chain stitch thread - 2400 Denier or equal

Steel Tubing

- All fabricated steel must be in accordance with approved shop drawings and calculations
- All steel is cleaned, degreased, or etched to ensure proper adhesion of Superdurable powder coat in accordance with manufacturer's specifications
- All Steel used on this project needs to be new and accompanied by the mill certificates if requested. Structural steel tubing up to 5"-7 gauge shall be galvanized per Allied Steel FLO-COAT specifications. Schedule 40 black pipe fabrications shall be sand-blasted and primed as described below
- All non-hollow structural shapes comply with ASTM A-36, unless otherwise noted
- All hollow structural steel shapes shall be cold formed HSS ASTM A-53 grade C, unless otherwise noted
- Plate products shall comply with ASTM A-36

Superdurable Powder Coat and Primer

- All non-galvanized steel shade to be sand-blasted and primed prior to Superdurable powder coating using reclaimable blast media in a mixture of GL50 & GL80 Steel Grit
- All non-galvanized steel must be coated with rust inhibiting primer prior to applying the Superdurable powder coat. Primer shall be Marine Grade Cardinal Industrial Finishes Corp. E396-GR1372 epoxy Superdurable powder coating semi-gloss smooth zinc rich primer
- Welds shall be primed with rust inhibiting primer prior to applying the Superdurable powder coat. Primer shall be Marine Grade Cardinal Industrial Finishes Corp E396-GR1372 epoxy Superdurable powder coating semi-gloss smooth zinc rich primer
- All steel parts shall be coated for rust protection and finished with a minimum 3.5 mil thick UV-inhibited weather resistant Superdurable powder coating

| Powder Coat Tests | | Results |
|-------------------|---|---------------------|
| ASTM | Gloss at 60° | 85-95 |
| HOI TM 10.219 | PCI Powder Smoothness | 7 |
| ASTM D2454-91 | Over-Bake Resistance Time | 200% |
| ASTM D3363-92A | Pencil Hardness | H-2H |
| ASTM D2794-93 | Dir/Rev Impact, Gardner | 140/140 in/lbs |
| ASTM D3359-95B | Adhesion, Cross Hatch | 5B Pass |
| ASTM D522-93A | Flexibility Mandrel | ¼" dia. No fracture |
| ASTM B117-95 | Salt Spray | 1,000 hours |
| UL DtoV2 | Organic Coating Steel Enclosures, Elect Eq. | Recognized |

Powder Coat Process Characteristics

| | | |
|-------|-----------------------------|----------------------|
| N.3.1 | Specific Gravity | 1.68+/-0.05 |
| N.3.2 | Theoretical Coverage | 114+/- 4 ft 2/lb/mil |
| N.3.3 | Mass Loss During Cure | <1% |
| N.3.4 | Maximum Storage Temperature | 75° F |

Application Criteria

| | | |
|-------|--------------------------|-------------------------|
| N.5.1 | Electrostatic Spray Cold | Substrate:0.032 in. CRS |
| N.5.2 | Cure Schedule | 10 minutes at 400° F |
| N.5.3 | Pretreatment | Bonderite 1000 |
| N.5.4 | Film Thickness | 3.5 Mils |

Welds

- All shop welds shall be executed in accordance with the latest edition of the American Welding Society Specifications
- Welding procedures shall comply in accordance with the AWS D1.1-AWS Structural Welding Code-Steel
- All welds to be performed by a certified welder. All welds shall be continuous where length is not given, unless otherwise shown or noted on drawings
- All welds shall develop the full strength of the weaker member. All welds shall be made using E70xx.035 wire
- Shop connections shall be welded unless noted otherwise. Field connections shall be indicated on the drawings. Field welded connections are not acceptable
- All fillet welds shall be a minimum of ¼" unless otherwise noted
- All steel shall be welded shut at terminations to prevent internal leakage
- Internal weld sleeving is not acceptable
- On-site welding of any component is not acceptable

Sewing

- On-site sewing of a fabric will not be accepted
- All corners shall be reinforced with extra non-tear cloth and strap to distribute the load
- The perimeters that contain the cables shall be double lock stitched

Installation Hardware

- Bolt and fastening hardware shall be determined based on calculated engineering loads
- All bolts shall comply with SAE-J429 (Grade 8) or ASTM A325 (Grade BD). All nuts shall comply with ASTM F-594, alloy Group 1 or 2
- Upon request, Stainless Steel hardware shall comply with ASTM A-304
- 1/4" galvanized wire rope shall be 7x19 strand with a breaking strength of 7,000 lbs. for shades generally under 575 sq. ft. unless requested larger by the customer. For shades over 575 sq. ft., cable shall be 5/16" with a breaking strength of 9,800 lbs. Upon request, 1/4" Stainless Steel wire rope shall be 7x19 strand with a breaking strength of 6,400 lbs. 5/16" Stainless Steel wire rope shall be 7/19 strand with a breaking strength of 9,000 lbs.
- All fittings required for proper securing of the cable are hot dipped galvanized

Concrete

- Concrete work shall be executed in accordance with the latest edition of American Concrete Building Code ACI 318 unless specified by the governing municipality
- Concrete specifications shall comply in accordance with, and detailed as, per plans as follows:
 1. 28 Days Strength F'c = 2500 psi
 2. Aggregate: HR
 3. Slump: 3-5
 4. Portland Cement shall conform to C-150

CONCRETE CONTINUED ON NEXT PAGE

5. Aggregate shall conform to ASTM C-33

- All reinforcement shall conform to ASTM A-615 grade 60
- Reinforcing steel shall be detailed, fabricated and placed in accordance with the latest ACI Detailing Manual and manual of Standard Practice
- Whenever daily ambient temperatures are below 80° F, the contractor may have mix accelerators and hot water added at the batch plant (see table)
- The contractor shall not pour any concrete when daily ambient temperature is below 55° F

Concrete Temperate Chart

| Temperature Range | % Accelerator | Type Accelerator |
|--------------------------|----------------------|--------------------------|
| 75-80° | 1% | High Early (non calcium) |
| 70-75° | 2% | High Early (non calcium) |
| Below 70° | 3% | High Early (non calcium) |

Footings

- All anchor bolts set in new concrete shall be ASTM A-307, or ASTM F-1554 if specified by engineer
- All anchor bolts shall be zinc plated unless specified otherwise
- Footing shall be placed in accordance with and conform to engineered specifications and drawings

Shade Warranty

Superior Recreational Products (SRP) warrants that its product will be free from defects in materials and workmanship as well as maintain structural integrity for the periods listed below from the date of invoice and once SRP has been paid in full. This warranty is in effect only if the product has been assembled and installed strictly in accordance with the setup instructions provided by SRP, good construction practices, general maintenance and care is provided as per instructions in the customer packet, and has been subjected only to normal use and exposure. Product should be maintained per the instructions given at time of delivery.

- | | |
|--|---|
| LW Lifetime* Warranty on stainless steel hardware | 5 5-Year Limited Warranty on powder coat |
| 20 20-Year Limited Warranty on framework | 1 1-Year Limited Warranty on cables |
| 10 10-Year Limited Warranty on fabric | 1 1-Year Limited Warranty on materials not above |

The Limited Warranty excludes abnormal conditions, contingent liability, cosmetic defects such as scratches, dents, marring, stripping, peeling, or fading; damage due to incorrect installation, vandalism, misuse, accident wear and tear from normal use; exposure to extreme weather, immersion in salt or chlorine water, damage due to sand, salt spray, or other abrasive and corrosive material; unauthorized repair or modification, abnormal use, or lack of maintenance. The warranty does not cover damages due to "acts of God" such as hail, flooding, lightning, tornadoes, sand storms, shifts of terrain, earthquakes, mudslides, and wind-storms.

SRP does not warrant product for defects caused by erection, harsh site conditions, lack of maintenance, and/or other conditions beyond SRP's control. SRP will not be held responsible for any materials that were not properly stored prior to installation. SRP reserves the right to void the limited warranty if it not installed per the installation instructions and/or unauthorized modifications.

In the unlikely event of failure, SRP reserves the right to alter the design, color, or contributing factors to rectify the condition and help prevent any future reoccurrence(s). SRP has the option to repair or replace any defect in materials.

The warranty is void if any changes, modifications, additions, or attachments are made to the product without the written consent of the manufacturer.

No signs, objects, ornaments, fans, lights, fixtures, or decorations may be hung from the structure unless specifically designed and engineered by the manufacturer or has manufacturers written approval.

SRP excludes any implied warranty of merchantability, fitness, or purpose, and there are no warranties which extend beyond the description of the face hereof. Under no circumstances will SRP be responsible for any indirect, special, consequential, incidental, or liquidated damages due to breach of warranty and such damages are specifically excluded from the warranty.

The owner shall notify SRP with original Sales Order Number issued from SRP to arrange for an inspection within 30 days after discovery of any defect under this warranty and before any alteration or repair is made or attempted. This Limited Warranty shall be null and void if the owner makes any alterations in design.

This warranty is the only express warranty given by the company. No person has authority to change or add to these obligations and liabilities. The company reserves the right to determine whether the fault is caused by faulty workmanship, material, or the part that is defective.

SRP will repair or replace at its discretion any defective part/s on an Ex-Works basis only. It is the responsibility of the customer to return the whole unit or the defective part/s at their own cost back to SRP for inspection along with proof of the date of purchase. SRP will not be liable for any costs incurred by the customer as a result of replacing the defective part/s, including but not limited to the costs of site visits and the labor costs involved with the removal and reinstallation of the whole unit or the defective part/s. Furthermore SRP will not be liable for any claimed compensation while the unit is not working or not present at the site whatsoever. This guarantee does not entitle the customer to a complete new product due to a defective component.

Limited Warranty: Structural Steel

SRP offers a 20-year Limited Warranty on structural steel frames for shade canopies against failure due to rust-through corrosion under normal environmental conditions. Should the fabric or parts need to be replaced under the warranty, SRP will manufacture and ship new replacement parts at no charge for the first ten years, thereafter pro-rated at 10% per annum over the last ten years.

Workmanship is warranted for a period of five years. This steel warranty shall be void if damage to the steel is caused by the installer or from physical damage, damage by salt spray or sprinkler systems, contact with chemicals, chlorine, pollution, misuse, vandalism, or any act of God.

Limited Warranty: Powder Coat

Superior Recreational Products offers a 5-year Limited Warranty for powder coating to the original purchaser. This Limited Warranty is for factory applied finish only. Damage occurring from shipping, erection, vandalism, accidents, or field modification is not covered in this limited warranty and will require field touch-up immediately and periodically thereafter. The owner must report any defect in powder coat at the time the installation is completed. Not covered by this Limited Warranty are acute angles, welds, and end plates.

The Limited Warranty for powder coating provides the following after a 5-year exposure period when applied according to the recommendations listed on the product's technical data sheet and appropriate surface preparation has been utilized.

- The coatings shall retain their original color with a ΔE of <7.5 units for high chroma colors (yellows, reds, oranges, etc.) and a ΔE of <5.0 units for low chroma colors, when tested in accordance with ASTM D 2244.
- The coating shall retain a minimum of 50% of its original gloss level after washing, when tested in accordance with ASTM D 523.
- The coating shall exhibit chalking no worse than numerical rating of 6, when evaluated in accordance with ASTM D 659-80.

Limited Warranty: Shade Fabric

Traditional shade fabric made with PTFE fiber that is high strength and low shrinkage and VALMEX[®] MEHATOP F 1 waterproof fabric carry a 10-year limited warranty. This warranties that the sewing thread used on the traditional shade fabric will be free from defects in material and workmanship and will not be damaged by exposure to sunlight, weather, and water. All other warranties are disclaimed.

SRP fabrics carry a 10-Year Limited Manufacturer's Warranty from the date of delivery against failure from significant fading**, deterioration, breakdown, outdoor heat, cold, or discoloration. Should the fabric need to be replaced under the warranty, SRP will manufacture and ship new fabric at no charge for the first six years, thereafter pro-rated at 18% per annum over the last four years.

**The colors red and yellow are warranted against significant fading for only two years.

If the corners of the fabric are equipped with both holes in the fabric corner PLUS reinforcing straps, BOTH the strap and fabric hole must be placed over each corner hook or the fabric warranty is void.

Fabric curtains, valences, or flat vertical panels are not covered under the warranty.

Fabric is not warranted where it is installed on a structure that is not engineered and built by SRP or its agents.

This warranty shall be void if damage to or failure to the shade is caused by contact with chemicals, chlorine, bleaching agents, hydrocarbons or hydrocarbon containing solvents, misuse, vandalism, or any act of God, including but not limited to wind in excess of the wind limitations set forth below.

All fabric tops are warranted for sustained winds up to 76 mph (Hurricane Force 1) and for gusts of up to 3 seconds duration up to 90 mph. Removal of the shade fabric is required if damaging winds are called for. Damage due to snow and/or ice accumulation is not covered by this warranty. Canopies should be removed during the "off season."

These structures have been designed to eliminate any friction between the rafters and the fabric. The warranty will, therefore, be voided if any modification (temporary or permanent) is made to the rafter, cross pieces, or ridge beams, or if the fastening apparatus or canopy are not secured accordingly.

Structures are warranted for winds up to 90 or 105 mph only if shade canopies have been removed as per requirement set forth above in the fabric paragraph. Removal and re-installation must be performed by a qualified person or authorized dealer.

**For the purpose of this warranty, lifetime encompasses no specific term of years, but rather that seller warrants to its original customer for as long as the original customer owns the product and uses the product for its intended purpose that the product and all parts will be free from defects in materials and manufacturing workmanship. This warranty does not cover damage caused by vandalism, misuse or abuse, altered or modified parts, or cosmetic damage such as scratches, dents, or fading or weathering and normal wear and tear. This warranty is valid only if the structures are installed in conformity with instructions provided by Superior Recreational Products using approved Superior Recreational Products parts. Superior Recreational Products will deliver the repaired or replacement part or parts to the site free of charge, but will not be responsible for labor or the labor costs of replacement. Warranty claims must be filed within the applicable warranty period and accompanied by a sales order or invoice number.*

Policies

Pricing Policy

All prices are F.O.B. factor and do not include freight, installation, shipping and handling, surfacing, or applicable taxes. All prices listed were current at the time of printing and in U.S. currency. Prices are subject to change without notice.

Cancellation and Return Policy

To view our return policy, please visit superiorrecreationalproducts.com/returns. For information on Return Material Authorizations please call 1.800.327.8774.

Shipping Policy

To view our shipping policy, please visit superiorrecreationalproducts.com/shipping. For any further information please call 1.800.327.8774.

Appendix

Proper Care, Maintenance, and Safe Removal of the Shade Canopy

THINGS TO AVOID

SNOW, ICE, AND HIGH WINDS: Remove the canopy in winter conditions as ice and snow loads are not covered by the warranty. The same goes for winds in excess of hurricane force 1.

SHARP OBJECTS: Always avoid dragging the fabric across surfaces, etc. Roll or fold the fabric and carry it. Avoid sharp objects, bolts, snags, and other protrusions including mounting hardware.

OBSTRUCTIONS: Keep foliage, such as tree limbs, shrubbery, and bushes, trimmed back and away from fabric at least three to four feet.

SOURCES OF HEAT: Avoid contact with heat sources such as hot lights, torches, and avoid using grills, etc. under the fabric or fireworks near the fabric..

SLACK CABLE IN CANOPY: Canopies with loose cables can fail.

CLEANING THE FABRIC

The fabric itself is generally maintenance free with the exception of necessary removal due to weather or seasonal requirements. The fabric does not harbor mildew or mold, but residues such as tree sap, leaves, bird droppings, dust and dirt may need to be removed. To clean the fabric, use water and mild soap. A soft mop or soft broom may also be used. Cleaners that do not contain hydrocarbons, solvents, bleach or ammonia may be used. Use of solvents, hydrocarbons, bleach, and ammonia type cleaners will void the fabric warranty. A pressure washer may be used if necessary using a wide-spray nozzle.

CABLES AND HARDWARE

It is recommended that the cables be replaced every 3 to 4 years or if corrosion is visible, whichever comes first. Canopy cables that are not maintained at optimum tension will be subject to shorter lifespans and potential failures earlier than our recommend cable replacement scheduling. The cable ends must be wrapped with tape to secure any wires; thus, preventing the wires from tearing the fabric. Taping must be done when removing old cable as well as when installing new cable. Clamps should be replaced when the cable is replaced. If the cable appears slack on a still day (no wind), immediately have the cable and clamps re-tightened by a qualified person. The cable should not be slack.

GLIDE ELBOW™

Lubricate Glide Elbows™ annually and before operating. A waterproof grease is recommended such as a lithium-based grease or anti-seize thread lubricant.

STORAGE

Fabric must be stored in a clean, dry place free from snags, sharp edges, etcetera. The storage area must be rodent-free. Wrap all hardware fittings with rags or some other protector, as they can damage the fabric.

UNINSTALLING THE SHADE CANOPY

NECESSARY CARE: It is important to take necessary care when handling the fabric during removal and installation to prevent damage to the fabric as well as SAFE control of the fabric in a breeze or wind. The fabric is tough and engineered for use as a shade, but it can tear or cut when or if pulled over a snag or sharp item; it can puncture from bolts or other protruding objects; and it can melt from objects such as like cigarettes, matches, hot torch tips, sparks and the like. In addition, care must be exercised to avoid the fabric hooks after the fabric is unhooked from the elbow corners and sides of the structure where there are intermediate supports. It is best to wrap any connected mounting hardware to prevent it from harming the fabric.

PROPER AND SAFE: Based on the size of the canopy, several persons may be needed to properly and safely handle the fabric during the uninstalling process. You will need several commercial ladders or other means to work safely at heights such as scissor lifts, etc. It is advised that you pad the post side of the ladder and tie the ladder to the post. The pad is to protect the post finish. Also keep in mind that every 100 square feet of fabric (10' X 10') weighs approximately five pounds; a large canopy can get heavy fast. For proper control of the fabric, read below. It is best to remove the fabric on a still day. Do not attempt to remove the canopy in strong or gusty winds.

REMOVAL OF THE CANOPY: Do not attempt to remove the canopy in strong or gusty winds.

STANDARD ELBOWS: For shade structures with Standard Elbows, loosen the turnbuckle several turns in order to put enough slack in the cable to allow the fabric and cable to unhook from all the elbow hooks. Attach 3/8" or larger ropes to each corner of the fabric and cable before unhooking to secure and properly control the fabric from ground level. If uninstalling in breezy conditions, choose the windy side of the fabric and tie these corners to the posts with the ropes with enough slack to allow for unhooking the fabric from the structure. These ropes are to prevent the shade from flying away in the breeze and to help prevent injury to ground personnel. Once the corners have been secured to the posts, unhook the fabric and cables from each corner.

On the side away from the wind, release the corners of the fabric and cable and have a person hold on to each rope. It may help to wrap the rope around a column to help hold it from getting caught in the wind. Fold the fabric back away from the hooks. Now it will be necessary to remove the cable clamps to allow the cable to be free from the structure and the turnbuckle. If the cable ends are frayed, wrap them with tape. It is usually not necessary nor is it recommended that the cable be removed from the canopy. With a person on each rope, starting at the windy side, gently pull the canopy down in between the framework of the structure. The side away from the wind can be guided with the ropes toward the persons pulling the canopy down. It is important when reinstalling the canopy, that it is put back in its original orientation to the structure. Starting at the turnbuckle corner, the fabric and cable corners should be returned to their original positions.

GLIDE ELBOWS: For shade structures with Glide Elbows, remove the protective covers from the ends of the glide elbows. Then, using the proper wrench, turn the hex nuts on the end of the Glide Elbow to run the glide hooks to their top most position. Do not loosen the cable clamps, leave the cable intact. Attach 3/8" ropes to each corner of the fabric and cable before unhooking to secure and properly control the fabric from ground level. If uninstalling in breezy conditions, choose the windy side of the fabric and tie these corners to the posts with the ropes with enough slack to allow for unhooking the fabric from the structure. These ropes are to prevent the shade from flying away in the wind and to help prevent injury to ground personnel. Once the corners have been secured to the posts, unhook the fabric and cables. On the side away from the wind, release the corners of the fabric and cable and have a person hold on to each rope. Fold the fabric back away from the hooks. It is a good idea to put the Glide Elbow protective covers back in place. With Glide Elbow installations it is not necessary to loosen or remove the cable clamps nor to remove the cable from the canopy. If the cable ends are frayed, wrap them with tape. When uninstalling the canopy, mark or identify the corner of origin in such a way that when reinstalling the canopy, it is put back in its original orientation to the structure. The fabric and cable corners should be returned to their original positions when reinstalling the canopy. The cable and fabric should tighten properly when the glide elbows are adjusted down into their tension positions.

SHADE SAILS WITH FANS: For shade sails equipped with fans, loosen the adjustable threaded rod several turns in order to put enough slack in the cable to allow the shackle pin to be removed (do not remove the pins until the fabric corners have been secured with ropes). Attach 3/8" or larger ropes to each corner of the fabric and fan before unhooking to secure and properly control the fabric from ground level. If uninstalling in breezy conditions, choose the windy side of the fabric and tie these corners to the posts with the ropes with enough slack to allow for unhooking the shackle from the structure. These ropes are to prevent the shade from flying away in the breeze and to help prevent injury to ground personnel. Once the corners have been secured to the posts, unhook the shackles and lower the fabric and cable to the ground.

REINSTALLING HINTS

Using the same rope technique, install from the windy side (if it is breezy) making sure to secure these ropes to the posts. Then, throw the remaining corner ropes over the structure and gently pull the canopy into position. The cables and fabric corners can now be fastened on the hooks (and cable guides if so equipped). Next reinstall the clamps if applicable and tightened the cable with the turnbuckle or the Glide Elbows. Do not attempt to install the canopy in strong or gusty winds.

3.



S O L U T I O N S

BY: BAILEY CONSULTING, INC.

PHONE: (386) 405-0433 FAX: (386) 313-5692

PROPOSAL

October 16, 2024
Palencia Miniature Golf

Attention: Erin Gunia

Bailey Consulting proposes to furnish all labor and materials necessary to complete the following:

- Remove and discard all existing turf and prep golf hole for installation of new turf.
 - Labor and material to install new turf on golf holes. (\$18,000.00)
- Labor and material to create faux hand carved concrete rocks in areas where brick are missing. (\$1,500.00)
- Labor and material to paint all concrete rocks and log. (\$800.00)
- Labor and materials to install 9 new hole number signs. (\$1,500.00)
- Clean site of all debris.

All work shall be completed in a workman like manner for the sum of:

Twenty One Thousand & Eight Hundred Dollars (\$21,800.00) U.S. Currency.

A 20% deposit (\$4,360.00) to be made prior to mobilization.

The cost of construction is not to exceed the contract price.

All invoices are paid net 30. Invoices processed for payment on the 10th of each month, payments to be scheduled on the 15th of each month.

Payments to be made based on a progress of completion.

Any alterations, additions or deviations from the proposal stipulations involving extra cost of material or labor resources will only be executed upon written change orders for the same. All change orders to be included as part of the revised contract amount. All agreements must be made in writing.

This proposal is good for Thirty (30) days.

Respectfully Submitted,

Date:

Matt Bailey, Owner

Accepted By:

Date:

PHONE: (386) 405-0433 FAX: (386) 313-5692

711 Dolphin Head Ln. - Ormond Beach Florida - 32174



4.



equipment | sales | service

P.O. Box 398

Lewis Center, OH 43035

740-548-7033 - office

740-548-7044 - fax

Bill To:

Sweetwater Creek Community

Development District

475 W Town PL Ste 114

St Augustine, FL 32092

Proposal

| Proposal Number | Proposal Date |
|-----------------|---------------|
| 31761 | 11/19/2024 |

www.design2wellness.com

Ship To:

1865 North Loop Parkway

| Product # | Product Description | Qty | Unit Price | Total |
|----------------------|---|-----|------------|-----------|
| | ***Strength Machines*** | | | |
| G3-S13 | Matrix Aura Converging Chest Press | 1 | 3,510.00 | 3,510.00 |
| G3-S22 | Matrix Aura Rear Delt/Fly | 1 | 3,601.00 | 3,601.00 |
| G3-S34 | Matrix Aura Diverging Seated Row | 1 | 3,413.00 | 3,413.00 |
| G3-S71 | Matrix Aura Leg Extension | 1 | 3,159.00 | 3,159.00 |
| G3-S72 | Matrix Aura Seated Leg Curl | 1 | 3,159.00 | 3,159.00 |
| G7-S70B-H | Matrix Ultra Leg Press Heavy Stack | 1 | 7,384.00 | 7,384.00 |
| VS-S40-USB2 | Matrix Versa Biceps Curl Heavy Stack | 1 | 2,490.00 | 2,490.00 |
| MG-MR690 | Matrix Mega 8' Half Rack (no spotter stands) | 1 | 3,406.00 | 3,406.00 |
| MG-PL13 | Matrix Supine Bench Press | 1 | 1,859.00 | 1,859.00 |
| MG-PL79 | Matrix Magnum Plate Loaded Squat Lunge | 1 | 1,430.00 | 1,430.00 |
| VS-S23-USB2 | Matrix Versa Converging Shoulder Press Heavy Stack | 1 | 3,094.00 | 3,094.00 |
| VS-S33-USB2 | Matrix Versa Diverging Lat Pulldown Heavy Stack | 1 | 3,094.00 | 3,094.00 |
| VS-S42-USB2 | Matrix Versa Triceps Press Heavy Stack | 1 | 2,490.00 | 2,490.00 |
| VS-S531-02B2 | Matrix Versa Low Back/AB Heavy Stack | 1 | 2,633.00 | 2,633.00 |
| VS-S74-USB2 | Matrix Versa Duals Hip Abductor/Adductor Heavy Stack | 1 | 2,886.00 | 2,886.00 |
| VS-VFT HS + VS-FTS18 | Matrix Functional Trainer Heavy Stack, 18" Storage | 1 | 4,368.00 | 4,368.00 |
| G3-MS40 | Matrix Aura 4-Stack Multi-Station, includes G3-MS23 Adj Pulley, G3-MS52 Tricep Pushdown, G3-MS51 Lat Pulldown, G3-MS53 Low Row & G3-MS40CK Connector Piece | 1 | 8,086.00 | 8,086.00 |
| 711SM | TKO Squat Machine | 1 | 1,787.00 | 1,787.00 |
| MG-A82 | Matrix/Magnum Multi-Adj Bench, LP | 3 | 1,099.00 | 3,297.00 |
| 9NP-B7524-60AAS | Nautilus Stretch Trainer, Black | 1 | 756.00 | 756.00 |
| MG-PL62 | Matrix Magnum Plate Loaded Smith Machine | 1 | 4,108.00 | 4,108.00 |
| | ***Indoor Cycling Bikes*** | | | |
| 9-7340-QINTPO | Schwinn AC Sport Group Cycle Bike | 8 | 1,417.625 | 11,341.00 |
| Shipping | Shipping Charges directly to customers location from the manufacturer. D2W installation team will be there to unload semi truck. | | 5,125.00 | 5,125.00 |
| Installation | Delivery & Installation | | 4,200.00 | 4,200.00 |
| Discount - Trade-in | Trade-in Discount | | -7,350.00 | -7,350.00 |
| | LifeFitness Pieces: Pec/Fly, Row, Ab Bench, Leg Ext, Leg Curl, Bicep Curl, Smith Machine, Shoulder Press, Tricep, Low Back, Chest Press, Leg Press, Lat Pulldown, Inner/Outer Thigh, Dual Adj Pulley, Preacher curl Bench & 4 Stack Multi Gym | | | |

Total

Kelly Naylor
knaylor@design2wellness.com
mobile 740-816-1884

Sales Representative

Customer Signature and Date

Terms:

Net 30 After Delivery

Please accept this signed quotation as a purchase order and acceptance of the price, terms and conditions below:

Standard terms are 50% deposit and balance due upon delivery or approved purchase orders.

All quotes are valid for 30 days from date of issue.

Restocking fees, storage fees or other penalties may be charged for cancellations, delays or

For complete terms & conditions please visit design2wellness.com.

Proposal Expires On

12/19/2024

returns.



equipment | sales | service

P.O. Box 398
Lewis Center, OH 43035
740-548-7033 - office
740-548-7044 - fax

475 W Town PL Ste 114
St Augustine, FL 32092

Proposal

| Proposal Number | Proposal Date |
|-----------------|---------------|
| 31761 | 11/19/2024 |

www.design2wellness.com

Bill To:
Sweetwater Creek Community
Development District

Ship To:
1865 North Loop Parkway
St. Augustine, FL 32095

| Product # | Product Description | Qty | Unit Price | Total |
|-----------|---------------------|-----|--------------|-----------|
| | Total sales tax | | 0.00 | 0.00 |
| | | | Total | 83,326.00 |

Kelly Naylor
knaylor@design2wellness.com
mobile 740-816-1884

Sales Representative

Customer Signature and Date _____

| Terms: |
|-----------------------|
| Net 30 After Delivery |

Please accept this signed quotation as a purchase order and acceptance of the price, terms and conditions below:

Standard terms are 50% deposit and balance due upon delivery or approved purchase orders.

All quotes are valid for 30 days from date of issue.

Restocking fees, storage fees or other penalties may be charged for cancellations, delays or returns.

For complete terms & conditions please visit design2wellness.com.

| Proposal Expires On |
|---------------------|
| 12/19/2024 |

5.

Storage Hallway-Invision Construction

| Items | Description | Cost Type | Qty/Unit | Unit Price | Price |
|-------------------------------------|--|---------------|----------|------------|------------|
| Interior wall Lumber | 2x4's, SYP & pressure treated | Material | 1 | \$290.00 | \$290.00 |
| Structural Framing Labor | | Labor | 6 | \$125.00 | \$750.00 |
| Door Install | | Labor | 2 | \$185.00 | \$370.00 |
| French door | Interior French door to match other doors (stainable) solid pine doors 4' x 8' french doors | Material | 2 | \$1,475.00 | \$2,950.00 |
| Drywall Finishing | Drywall Finishing | Subcontractor | 1 | \$900.00 | \$900.00 |
| Misc Materials | Tape, Mesh, mud, corner bead, sand paper | Material | 1 | \$170.00 | \$170.00 |
| Interior Paint - Walls & door stain | Prep and paint interior with Sherwin williams interior "SuperPaint". Satin prep and stain both sets of doors | Subcontractor | 1 | \$950.00 | \$950.00 |
| Door Hardware | door handles to match existing two sets per french door | Material | 4 | \$75.00 | \$300.00 |
| Electrical Rough | add 2 outlets in new storage room | Subcontractor | 1 | \$500.00 | \$500.00 |

Storage Hallway Total:

\$7,180.00

6.

ESTIMATE

C Buss Enterprises
152 Lipizzan Trail
Saint Augustine, FL 32095

clayton@cbussenterprises.com
+1 (904) 710-8161
<https://www.cbussenterprises.com>



Bill to
SweetWater Creek CDD
1001 Bradford Way
Kingston, TN 37763

Ship to
SweetWater Creek CDD
1879 N. Loop Pkwy
Saint Augustine, FL 32095

Estimate details

Estimate no.: 1581
Estimate date: 11/01/2024

| B# | Product or service | Description | Qty | Rate | Amount |
|----|--------------------|--|-----|--------------|--------------------|
| 1. | POOL PARTS | -NEW LEGACY STARTING PLATFORM (MID-RANGE) -H-HANDLE ON FRONT -FRAME COLOR: SILVER GRAY -SAND TREAD COLOR: WHITE | 6 | \$3,398.24 | \$20,389.44 |
| 2. | POOL PARTS | -NEW VELOCITY STARTING PLATFORM (MID-RANGE) W. SIDE STEP -H-HANDLE ON FRONT -FRAME COLOR: SILVER GRAY -SAND TREAD COLOR: WHITE -TRACK START WEDGE (5 POSITIONS) TUCKS UNDER FOOTBOARD WHEN NOT IN USE | 2 | \$4,432.29 | \$8,864.58 |
| 3. | LABOR | INSTALLATION LABOR *SHIPPING INCLUDED* | 1 | \$755.00 | \$755.00 |
| | | | | Total | \$30,009.02 |

Accepted date

Accepted by

7.

***Proposal to Both Marshal Creek and Sweetwater CDD
Board of Supervisors***

***Creation and Use of Land Space Between
Glorieta and Vale Drive for Events***



View from middle of road at midway point looking
from Glorieta Drive to Vale Drive

The land between Vale Drive and Glorieta Drive is owned and maintained by Sweetwater Creek. The proposal is to allow both Marshal Creek and Sweetwater to utilize this area for events. Primary usage would be to host movie nights, but other venues could be imagined to be utilized there as well.

The location is excellent in that it would not interfere with neighbors and the area allows for golf cart parking, space for food trucks and minimal impact on either neighborhood. The current idea is to not allow cars to be parked in either neighborhood and allow drop off and pick up only. Golf carts would be the only vehicles allowed into the area and parking for over 50 golf carts can easily be handled allowing for parking on both sides of the wide paved path between the two neighborhoods and having the emergency roadway not impacted.

There is electricity currently at the end of Vale Drive which would need to be expanded to create outside electrical boxes closer to the middle of the venue for projectors and speaker amplifiers. Electrical boxes could also be established closer to Vale Drive where the projected food trucks could be parked which would minimize any noise created by food truck generators for the closest residential homes on Vale Drive.

The area around the pond will need to be roped off with barricades to prevent anyone from venturing too close to the water.

Cost to run the electricity will need to be looked into. It is thought that both communities can utilize this space, that the cost for the electrical would be split 50/50.

Other additional costs would be for port-a-potty rentals for each event.

The attached diagram illustrates the proposal along with pictures of the area.



View at middle of property looking from Vale Drive towards Glorieta Drive



View at middle of property looking to the right of the pond



Area across from pond



View from middle of roadway to the left and center area of pond



Second photo of area across from pond

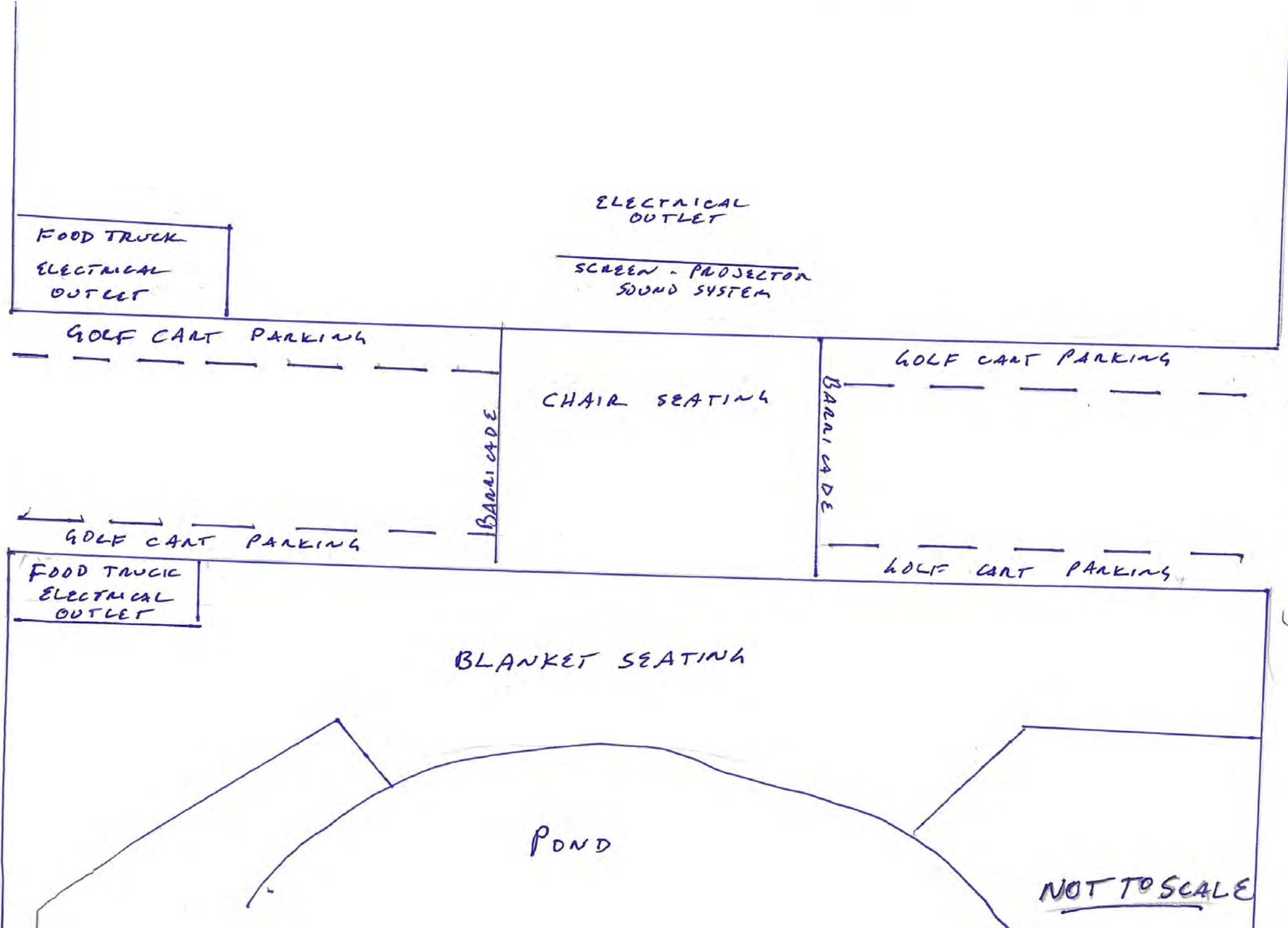

GLOBEVIEW OUTLET